

# A

# VARIABLE DISPLACEMENT PISTON PUMPS

Pump Type	Maximum Operating Pressure MPa (PSI)	Geometric Displacement		Catalogue No.
		cm <sup>3</sup> /rev	cu. in./rev	
"AR" Series Variable Displacement Piston Pumps	16 (2320)		AR16, AR22	Pub. EC-0104
"A" Series Variable Displacement Piston Pumps	Single Pumps	21 (3050)	A10, A16	Pub. EC-0105
		16 (2320)	A22	
		21 (3050)	A37, A56	
		28 (4060)	A70, A90, A145	
		28 (4060)	Outboard Pump: A16, A22, A37, A56 Inboard Pump (Driven End): A16, A22, A37, A56, A70, A90, A145	
28 (4060)	Outboard Pump: RV2R1, RV2R2 Inboard Pump (Driven End): A16, A22, A37, A56, A70, A90, A145			
"AH" Series Variable Displacement Piston Pumps	31 (4500)		AH16, AH37, AH56	Pub. EC-0106

Up to 16 MPa (2320 PSI), 22.2 cm<sup>3</sup>/rev (1.35 CU.IN./rev)

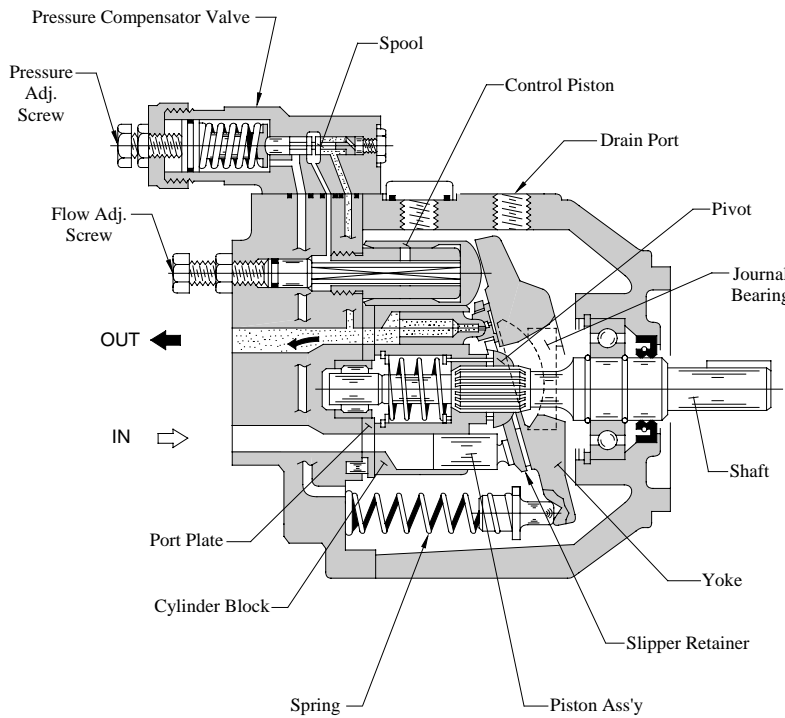

Graphic Symbol

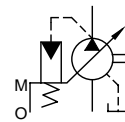

**Features**

● **Smaller in Size and Lighter in Mass**

As indicated in the dimensional comparison presented below, the AR16 is smaller than the A16 (32 design). Also, the mass of AR16 is substantially lighter than the A16.

● **Low Noise**

The noise level of AR16 has been reduced by 1-2 dB (A) at full flow and full cut-off compared with that of the excellent A16 quiet pump.

**[Comparison of "AR16" with "A16"]**

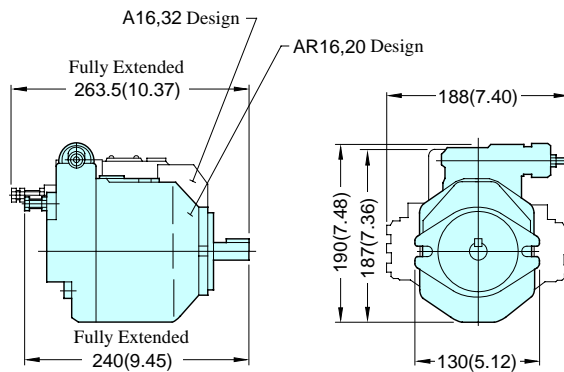

**DIMENSIONS IN MILLIMETRES (INCHES)**

Model	Approx. Mass (Flange Mtg.)	Ratio of Mass (AR16/A16)
AR16	9.8 kg (21.6 lbs.)	60 %
A16	16.5 kg (36.4 lbs.)	

# Instructions

## 1. Hydraulic Fluids

Use petroleum base oils such as anti-wear type hydraulic oils or R & O (Rust and Oxidation inhibitor) type hydraulic oils equivalent to ISO VG-32 or 46. The recommended viscosity range is from 20 to 400 mm<sup>2</sup>/s (98 to 1800 SSU) and temperature range is from 0 to 60°C (32 to 140°F), both of which have to be satisfied for the use of the above hydraulic oils.

## 2. Control of Contamination

Due caution must be paid to maintaining control over contamination of the operating oil which can otherwise lead to breakdowns and shorten the life of the unit. Please maintain the degree of contamination within NAS Grade 10.

The suction port must be equipped with at least a 100 μm (150 mesh) reservoir type filter and the return line must have a line filter of under 10 μm.

## 3. Mounting

When installing the pump the filling port should be positioned upwards.

## 4. Alignment of Shaft

Employ a flexible coupling whenever possible, and avoid any stress from bending or thrust.

Maximum permissible misalignment is less than 0.1 mm (.004 inches) TIR and maximum permissible misangular is less than 0.2°.

## 5. Suction Pressure

Permissible suction pressure at inlet port of the pump is between -16 and +50 kPa (5 in.Hg Vacuum and 7 PSIG).

For piping to the suction port, use the pipes of the same diameter as that of the specified pipe flange to be used. Make sure that the height of the pump suction port is within one metre (3.3 ft) from the oil level in the reservoir.

## 6. Hints on Piping

When using steel pipes for the suction or discharge ports, excessive load from the piping to the pump generates excessive noise.

Whenever there is fear of excessive load, please use rubber hoses.

## 7. Suction Piping

In case the pump is installed above the oil level, the suction piping and suction line filter should be located lower than the pump position to prevent air in the suction line.

## 8. Drain Piping

Install drain piping according to the chart and ensure that pressure within the pump housing should be maintained at a normal pressure of less than 0.1 MPa (14.5 PSI) and surge pressure of less than 0.5 MPa (72.5 PSI).

Length of piping should be less than 1 m (3.3 ft.), and the pipe end should be submerged in oil.

In case AR16 and AR22 pump, a screw-in torque of fitting is 40 to 50 Nm (354 to 443 IN.lbs.). Do not apply bending and thrust torque to the fitting.

**[Recommended Drain Piping Size]**

Model	Fitting Size	Inside Dia. of Pipe
AR16, AR22	3/8 [Inside Dia. 8.5 mm (.33 in.) or more]	10 mm (.39 in.)

## 9. Bleeding Air

It may be necessary to bleed air from pump case and outlet line to remove causes of vibration. An air bleed valve (Model No. ST1004-\*-10\*, Catalogue No.: Pub. EC-3001) is recommended for this purpose.

**10. Starting**

Before first starting, fill pump case with clean operating oil via the fill port.

In order to avoid air blockage when first starting, adjust the control valves so that the discharged oil from the pump is returned direct to the tank or the actuator moves in a free load.

**[Volume of Pre-fill Oil Required]**

Model	Volume cm <sup>3</sup> (in. <sup>3</sup> )
AR16 AR22	430 (26.2)

**11. Setting Discharge Pressure and Delivery**

At the time of shipment, the unit has been preset to maximum delivery and minimum discharge pressure

Adjust the preset delivery and pressure to meet your system requirements.

● **Adjustment of Discharge Pressure**

Turning the adjustment screw clockwise, increases pressure.

**[ Volume adjusted by each full turn of the pressure  
adjustment screw ]**

Model Numbers	Adjustment Volume MPa (PSI)
AR16/AR22-FR01B	2.9 (420)
AR16/AR22-FR01C	5.4 (780)

● **Adjustment of Delivery**

Turning the delivery adjustment screw clockwise, decreases delivery.

**[ The minimum adjustable flow and adjustable volume of  
each full turn of the delivery adjustment screw ]**

Model Numbers	Adjustable volume with each full turn of the adjustment screw cm <sup>3</sup> /rev (cu.in./rev)	Minimum adjustable flow cm <sup>3</sup> /rev (cu.in./rev)
AR16	1.5 (.092)	6 (.366)
AR22	2.1 (.128)	8.5 (.519)



Graphic Symbol

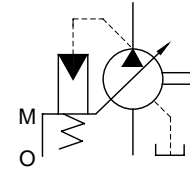

### Specifications

Model Numbers	Geometric Displacement cm <sup>3</sup> /rev (cu.in./rev)	Operating Pres. MPa (PSI)		Shaft Speed Range r/min.		Approx. Mass kg (lbs.)
		Rated	Intermittent ★1	Max.	Min.	
AR16-FR01*-20/2080/2090	15.8 (.964)	16 (2320)		1800	600	9.8 (21.6)
AR22-FR01*-20/2080/2090	22.2 (1.355)			1800	600	

★1. When setting the pressure, make sure the full cut-off pressure never exceeds the maximum intermittent pressure.

### Model Number Designation

AR16	-F	R	01	B	-20	*
Series Number	Mounting	Direction of Rotation	Control Type	Pres. Adj. Range MPa (PSI)	Design Number	Design Std.
<b>AR16</b> (15.8 cm <sup>3</sup> /rev)	<b>F:</b> Flange Mtg.	(Viewed from Shaft End) <b>R: ★1</b> Clockwise (Normal)	<b>01:</b> Pressure Compensator Type	<b>B:</b> 1.2 - 7 {170 - 1020} <b>C:</b> 2.0 - 16 {290 - 2330}	<b>20</b>	Refer to ★2
<b>AR22</b> (22.2 cm <sup>3</sup> /rev)					<b>20</b>	

★1. Available to supply pump with anti-clockwise rotation. Consult Yuken for details. ★2. Design Standards:

- None..... Japanese Standard "JIS"
- 80..... European Design Standard
- 90..... N. American Design Standard

### Pipe Flange Kits

Pipe flange kits are available.  
When ordering, specify the kit number from the table below.

Pump Model Numbers	Name of Port	Pipe Flange Kit Numbers				
		Threaded Connection			Socket Welding	
		Japanese Standard "JIS"	European Design Standard	N. American Design Standard	Japanese Standard "JIS" European Design Standard	N. American Design Standard
AR16-FR01	Suction	F5-06-A-1021	F5-06-A-10801	F5-06-A-10901	F5-06-B-1021	F5-06-B-10901
AR22-FR01	Discharge ★	_____	_____	_____	_____	_____

★ Discharge port is available only for the threaded connections.

#### ■ Pipe Flange Kit for Suction Port

#### F5-06-A-1021/10901 F5-06-B-1021/10901

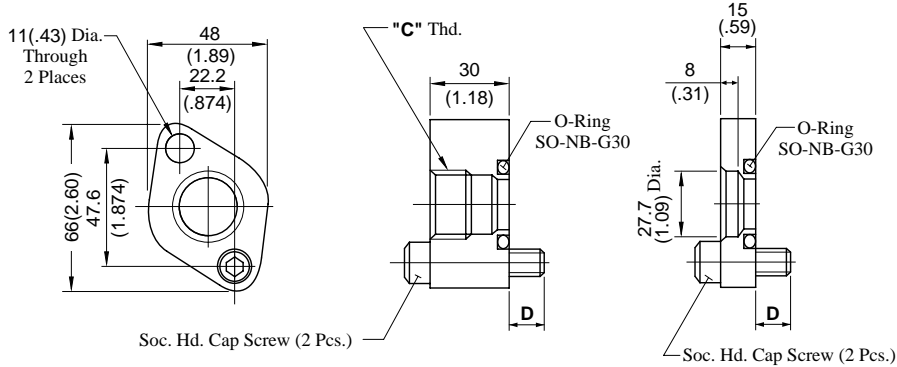

Kit Numbers	"C" Thd.	D mm (IN.)	Soc. Hd. Cap Screw	Approx. Mass kg (lbs.)
F5-06-A-1021	Rc 3/4	15 (.59)	M10 × 45 Lg.	0.5 (1.1)
F5-06-A-10901	3/4 NPT	14.45 (.57)	3/8-16UNC × 1-3/4 Lg.	
F5-06-B-1021	—	15 (.59)	M10 × 30 Lg.	0.3 (.66)
F5-06-B-10901	—	16.75 (.66)	3/8-16UNC × 1-1/4 Lg.	

#### F5-06-A-10801

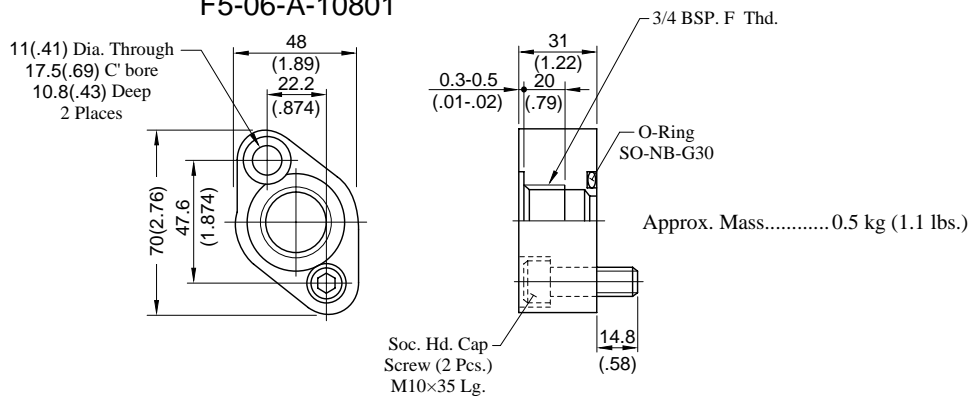

DIMENSIONS IN  
MILLIMETRES (INCHES)

#### ■ Mounting Bracket Kits

Mounting bracket available on separate order.

Pump Model Numbers	Mtg. Bracket Kit Numbers	Approx. Mass kg (lbs.)
AR16/AR22-FR01	LP-1A-10	2.2 (4.9)

Note: The mounting bracket kit consists of a mounting bracket, 2 hex. bolts and 2 plain washers.

#### Mtg. Bracket Kit: LP-1A-10

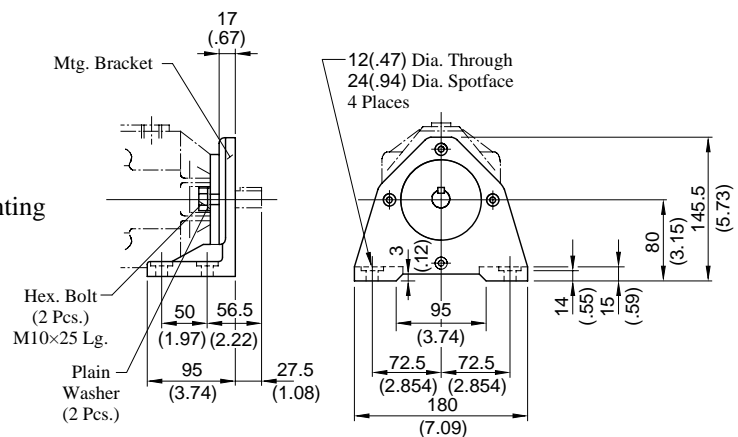

Type "AR 16" Viscosity 20 mm<sup>2</sup>/s (100 SSU) [ISO VG32 Oils, 50°C (122°F)]

#### Performance Characteristic Curve

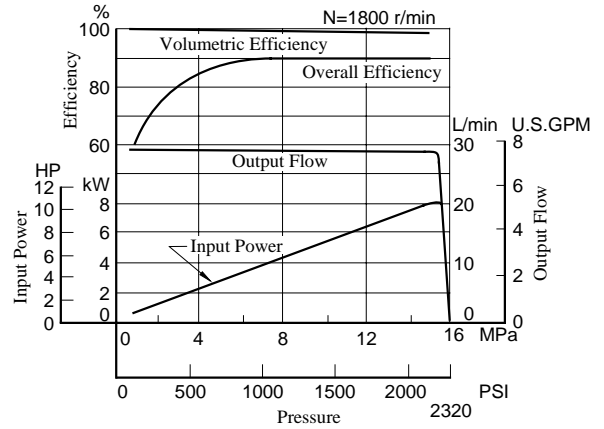
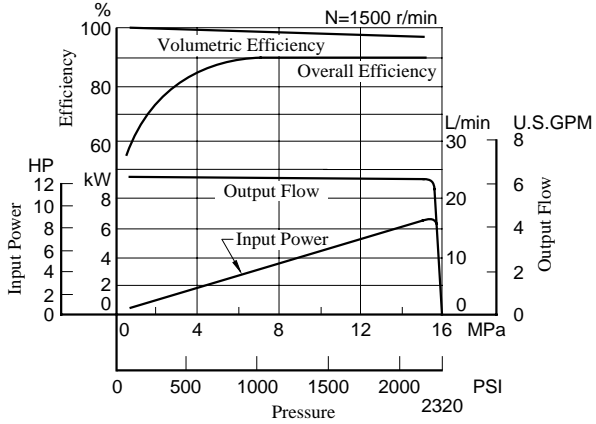

#### Input Power

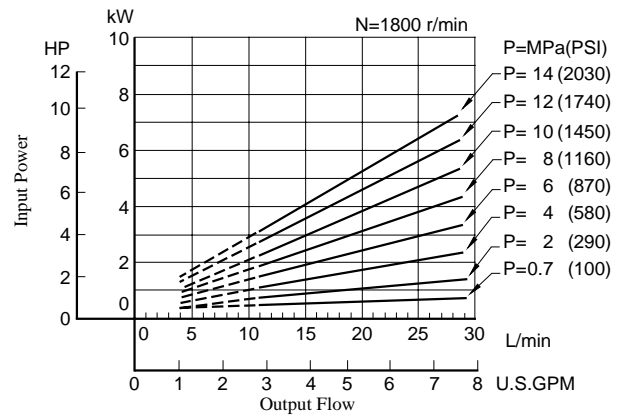
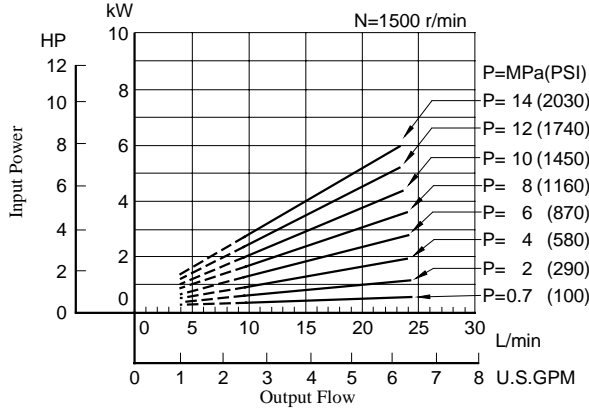

#### Full Cut-off Power

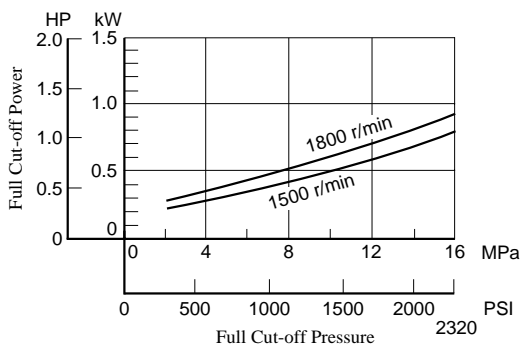

#### Drain

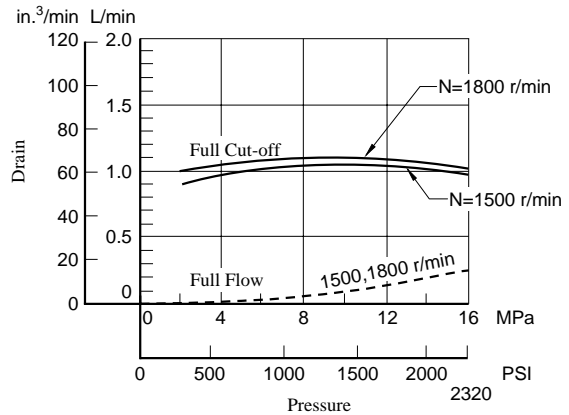

#### Noise Level [One metre (3.3 ft.) horizontally away from pump head cover]

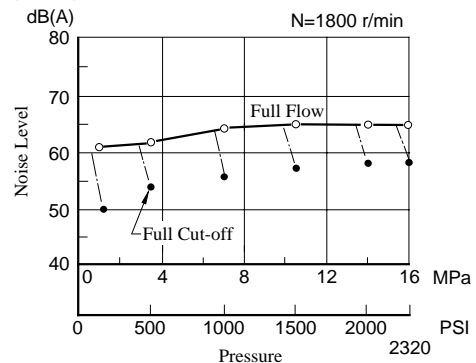
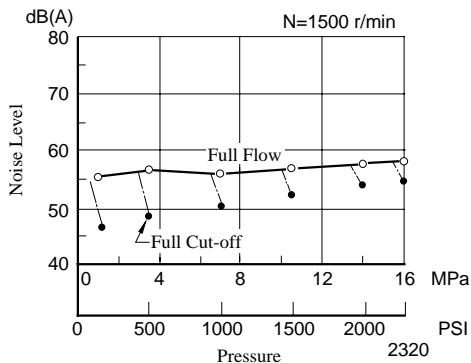

### Typical Pump Characteristics

Type "AR 22" Viscosity 20 mm<sup>2</sup>/s (100 SSU) [ISO VG32 Oils, 50°C (122°F)]

#### Performance Characteristic Curve

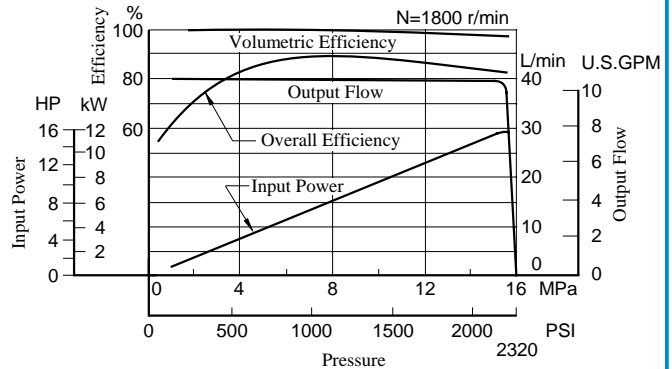
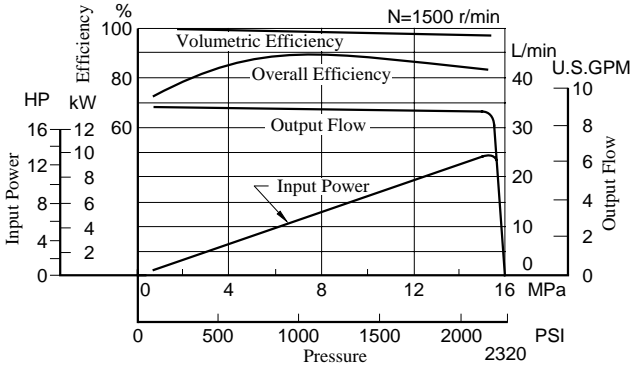

#### Input Power

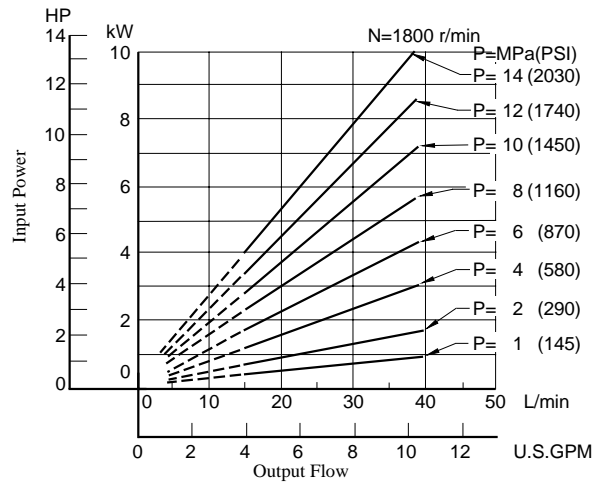
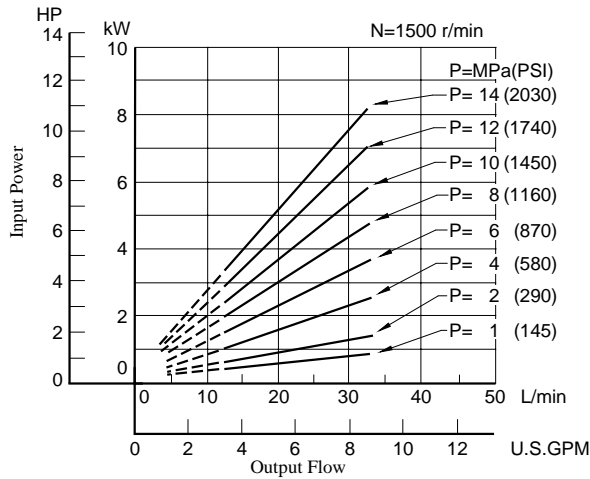

#### Full Cut-off Power

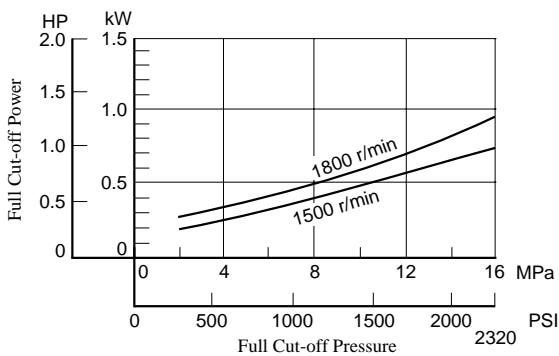

#### Drain

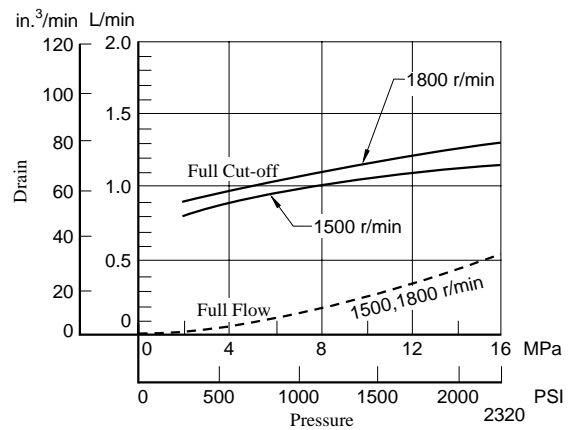

#### Noise Level [One metre (3.3 ft.) horizontally away from pump head cover]

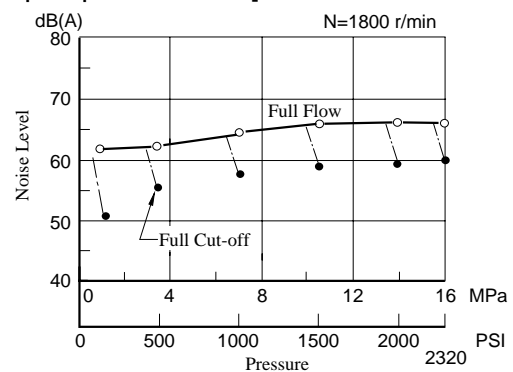
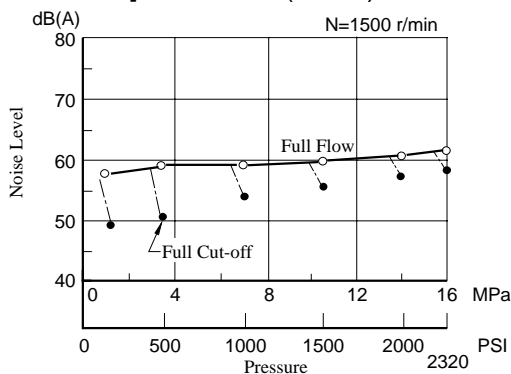



Response Characteristics Change in Accordance with Circuits and Operating Conditions.

#### Test Circuit and Conditions

##### Circuit

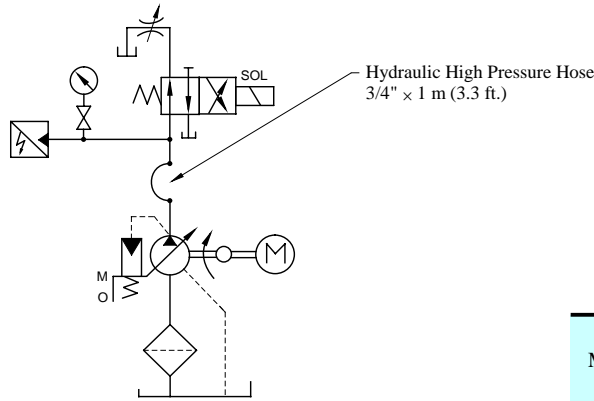

#### Result of Measurement

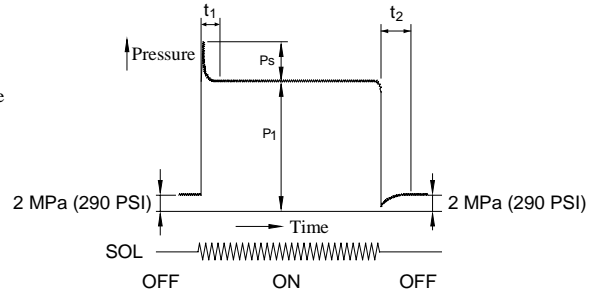

Model	Full Cut-off Pressure P <sub>1</sub> MPa (PSI)	Response Time ms		Overshoot Pressure MPa (PSI)
		t <sub>1</sub>	t <sub>2</sub>	
AR16	16 (2320)	60	65	5.6 (810)
AR22		70	70	7.3 (1060)

##### Conditions

- Drive Speed : 1500 r/min
- Hydraulic Fluid : ISO VG32 oil
- Oil Temperature : 50 °C (122 °F)
- Viscosity : 20 mm<sup>2</sup>/s (100 SSU)

AR16-FR01\*-20/2080/2090  
AR22-FR01\*-20/2080/2090

DIMENSIONS IN  
MILLIMETRES (INCHES)

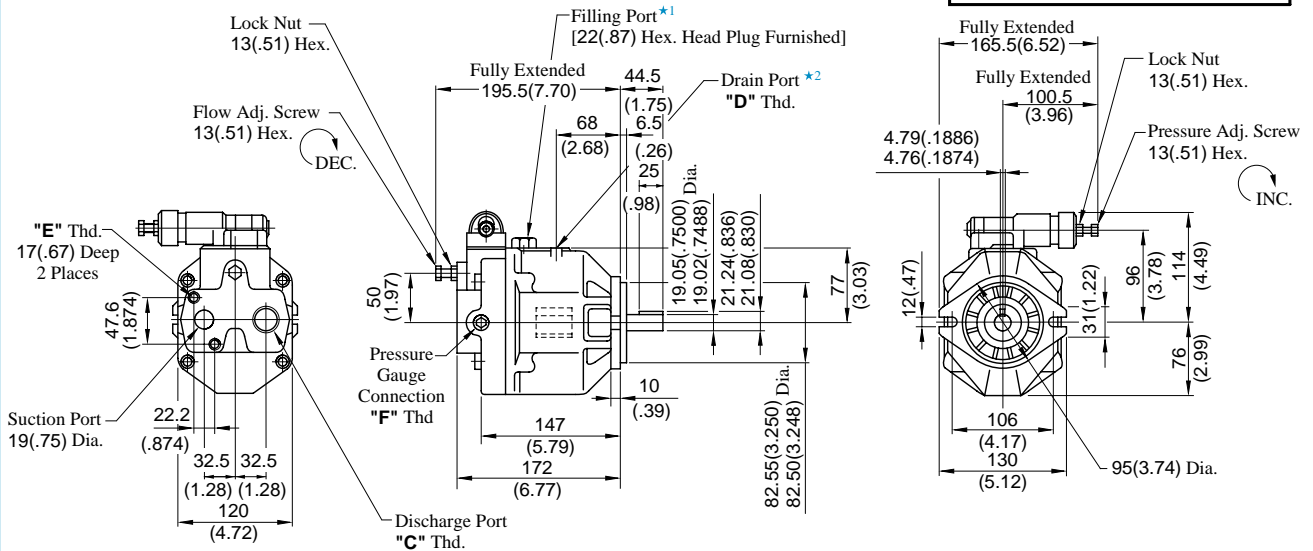

- ★1. Install the pump so that the "Filling port" is at the top.
- ★2. A screw-in torque of fitting is 40 - 50 Nm (354-443 IN.lbs.).  
Do not apply bending and thrust torque to the fitting.

Model Numbers	"C" Thd.	"D" Thd.	"E" Thd.	"F" Thd.
AR16/AR22-FR01*-20	Rc 3/4	Rc 3/8	M10	Rc 1/4
AR16/AR22-FR01*-2080	3/4 BSP.F	3/8 BSP.F		1/4 BSP.Tr
AR16/AR22-FR01*-2090	3/4 NPT	3/8 NPT	3/8-16 UNC	1/4 NPT

### Spare Parts List

AR16-FR01\*-20/2080/2090  
AR22-FR01\*-20/2080/2090

#### CAUTION

When making replacement of seals or bearing, please do it carefully after reading through the relevant instructions in the Operator's Manual.

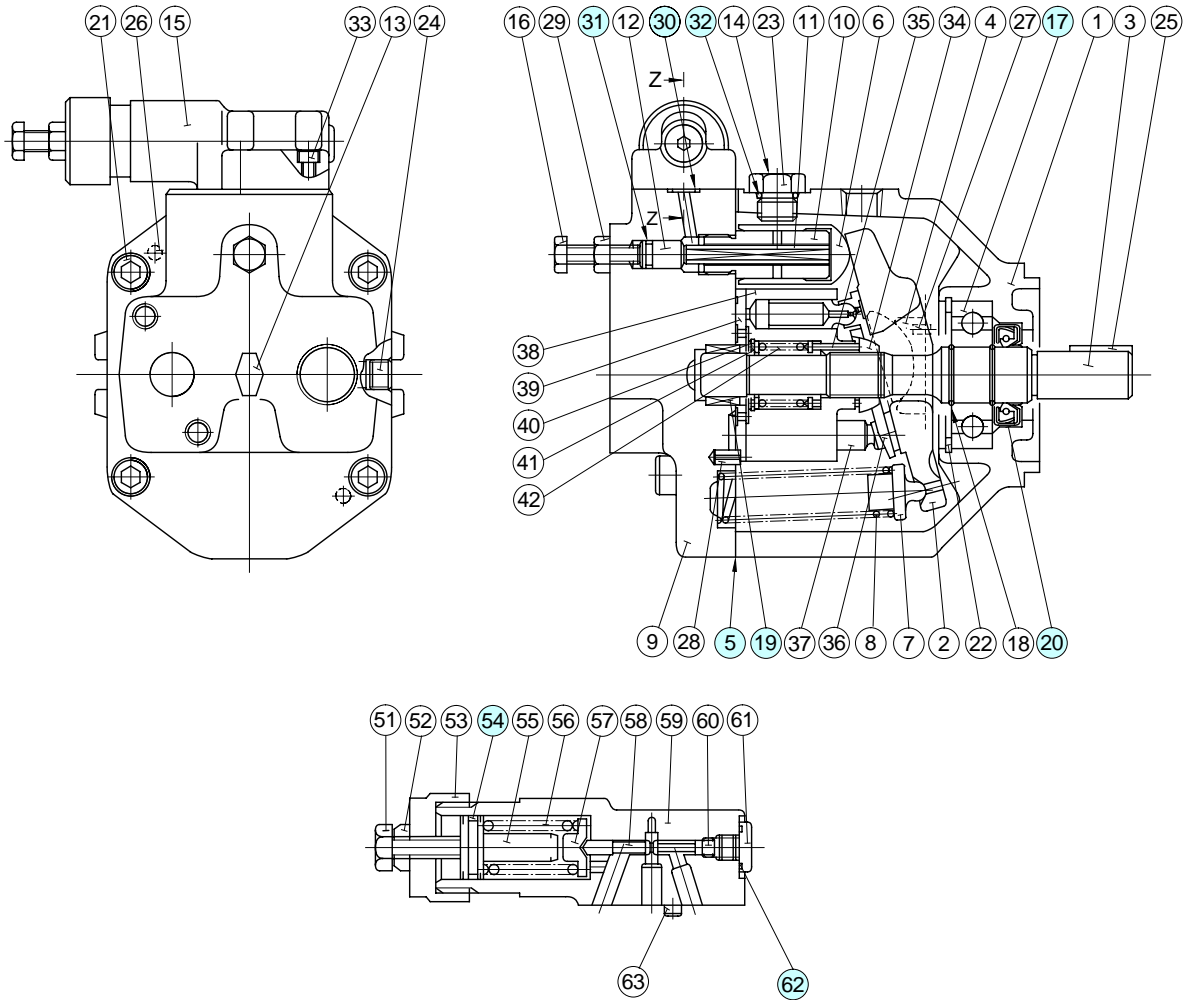

Section Z-Z

Item	Name of Parts	Part Numbers		Qty.
		AR16-FR01	AR22-FR01	
5*	Gasket	1302-PK312891-5		1
17	Bearing	6305		1
19	Bearing	HMK 1715 V2	Z30-1303-PK410300-8	1
20*	Oil Seal	TCN 254511		1
30*	O-Ring	SO-NB-P9		3
31*	O-Ring	SO-NA-P8		1
32*	O-Ring	SO-NB-P14		1
54*	O-Ring	SO-NA-A018		1
62*	O-Ring	SO-NB-P10		1

★ When ordering seals, please specify the seal kit number from the table below.

Pump Model Numbers	Seal Kit Number
AR16-FR01*-20/2080/2090	KS-AR16-01-20
AR22-FR01*-20/2080/2090	

#### Specifications

Description		Model	A16-*R-01-*K-32*	AR16-FR01*-20*	A22-*R-01-*K-32*	AR22-FR01*-20*
Geometric Displacement			15.8 cm <sup>3</sup> /rev (.964 cu.in./rev)		22.2 cm <sup>3</sup> /rev (1.355 cu.in./rev)	
Operating Pres.	Rated		16 MPa (2320 PSI)		16 MPa (2320 PSI)	
	Intermittent		21 MPa (3050 PSI)	16 MPa (2320 PSI)	16 MPa (2320 PSI)	
Shaft Speed Range			600 -1800 r/min		600 -1800 r/min	
Approx. Mass (Flange Mtg.)			16.5 kg (36.4 lbs.)	9.8 kg (21.6 lbs.)	16.5 kg (36.4 lbs.)	9.8 kg (21.6 lbs.)

#### Interchangeability in Installation

Model Numbers		Interchangeability in Installation			
"A" Series	"AR" Series	Mtg. Flange & Shaft End	Piping		
			Suction Port	Discharge Port	Drain Port
A16-*R-01-*K-32*	AR16-FR01*-20*	Yes	Yes	No	No
A22-*R-01-*K-32*	AR22-FR01*-20*				

Comparison of dimensions between "A" series and "AR" series are shown below.

#### A16/A22-F-R-01-\*K

Note: Dimensions with star mark ★ are identical to each other.

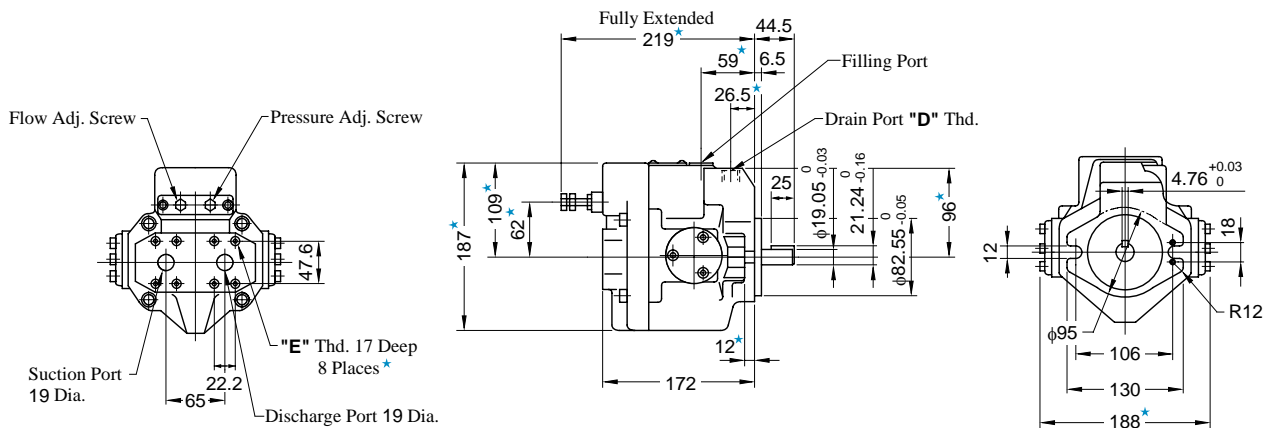

Model Numbers	"C" Thd.	"D" Thd.	"E" Thd.	"F" Thd.
A16/A22-F-R-01-*K-32	—	Rc 3/8	M10	—
A16/A22-F-R-01-*K-3280	—	3/8 BSP.F		—
A16/A22-F-R-01-*K-3290	—	3/8 NPT	3/8-16 UNC	—
AR16/22-FR01*-20	Rc 3/4	Rc 3/8	M10	Rc 1/4
AR16/22-FR01*-2080	3/4 BSP.F	3/8 BSP.F		1/4 BSP.Tr
AR16/22-FR01*-2090	3/4 NPT	3/8 NPT	3/8-16 UNC	1/4 NPT

#### AR16/AR22-FR01

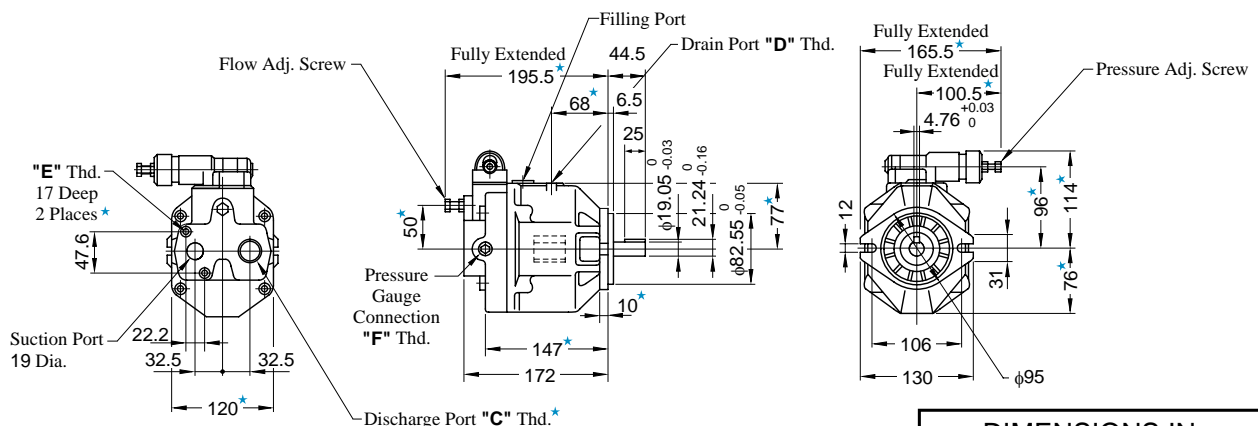

**DIMENSIONS IN  
MILLIMETRES**

Up to 28 MPa (4060 PSI), 145 cm<sup>3</sup>/rev (8.85 CU.IN./rev)

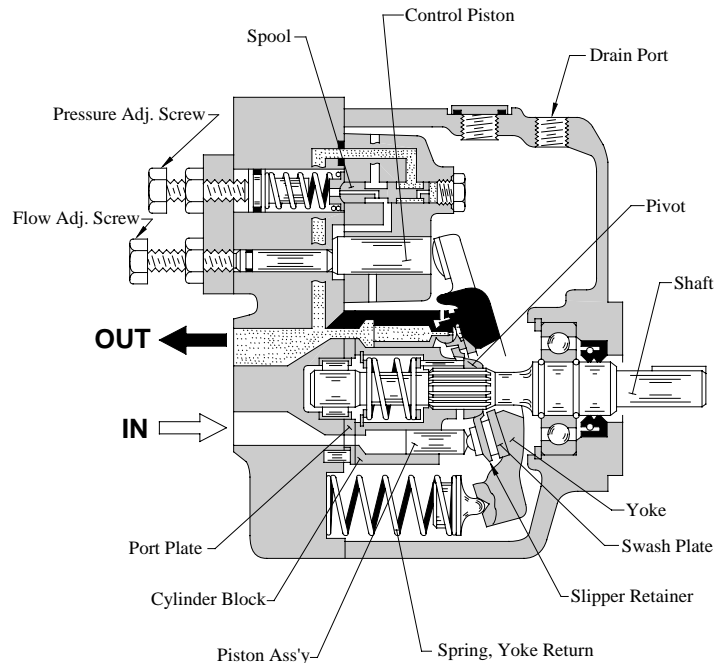
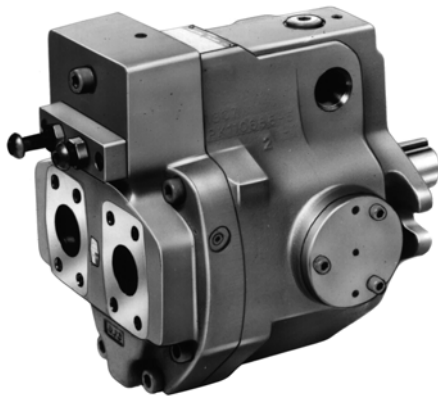

## Features

### High efficiency

Under the conditions of pressure 16 MPa (2320 PSI) and speed 1800 r/min, the volumetric efficiency is over 98% and the overall efficiency is over 90%.

### Low noise level

In the "A16" pump, the noise level is as low as 57.3 dB(A) [at the full cut-off pressure 21 MPa (3050 PSI) with speed 1500 r/min one metre (3.3 ft.) horizontally away from pump head cover.]

"A16" type performance characteristics

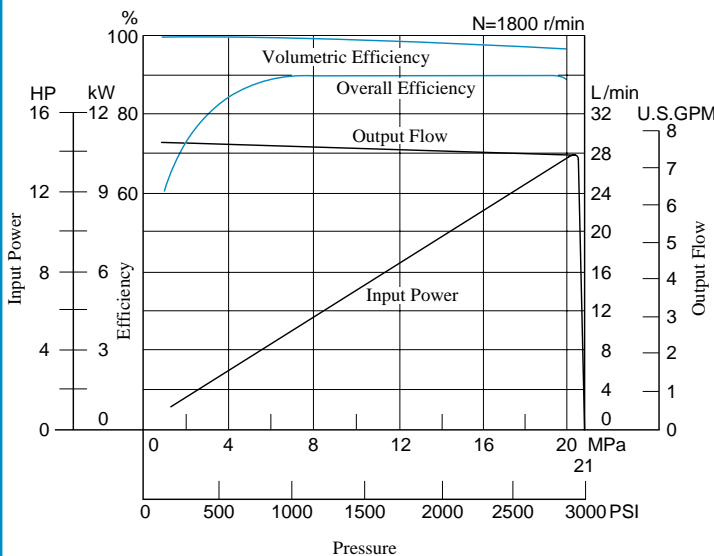

"A16" type noise level characteristics

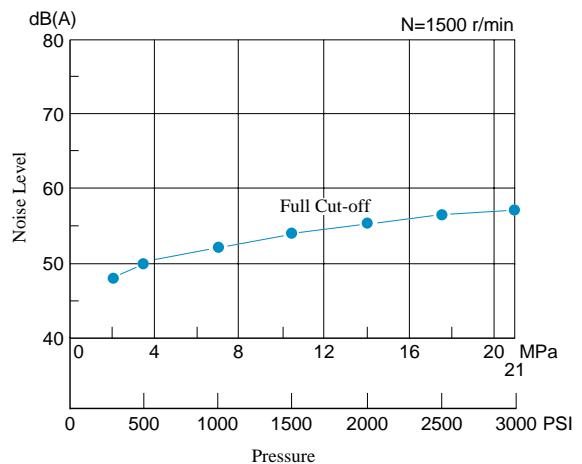

### Accomplishment of energy-saving

Because the overall efficiency is high and the cut-off characteristics is sharp, thus the input power may be saved.

### Low heat generation

Because of small power loss, it is possible to reduce the rise in oil temperature. Accordingly, capacity of a reservoir can be reduced.

# Instructions

## 1. Hydraulic Fluids

Use petroleum based oils such as anti-wear type hydraulic oils or R & O (Rust and Oxidation inhibitor) type hydraulic oils equivalent to ISO VG-32 or 46. The recommended viscosity range is from 20 to 400 mm<sup>2</sup>/s (98 to 1800 SSU) and temperature range is from 0 to 60° (32 to 140°F), both of which have to be satisfied for the use of the above hydraulic oils.

## 2. Control of Contamination

Due caution must be paid to maintaining control over contamination of the operating oil which can otherwise lead to breakdowns and shorten the life of the unit. Please maintain the degree of contamination within NAS Grade 10.

The suction port must be equipped with at least a 100 μm (150 mesh) reservoir type filter and the return line must have a line type filter of under 10 μm.

## 3. Mounting

When installing the pump the filling port should be positioned upwards.

## 4. Alignment of Shaft

Employ a flexible coupling whenever possible, and avoid any stress from bending or thrust.

Maximum permissible misalignment is less than 0.1 mm (.004 inches) TIR and maximum permissible misangular is less than 0.2°.

## 5. Suction Pressure

Permissible suction pressure at inlet port of the pump is between -16.7 and +50 kPa (5 in.Hg Vacuum and 7 PSIG).

For piping to the suction port, use the pipes of the same diameter as that of the specified pipe flange to be used. Make sure that the height of the pump suction port is within one metre (3.3 ft) from the oil level in the reservoir.

## 6. Hints on Piping

When using steel pipes for the suction or discharge ports, excessive load from the piping to the pump generates excessive noise.

Whenever there is fear of excessive load, please use rubber hoses.

## 7. Suction Piping

In case the pump is installed above the oil level, the suction piping and suction line filter should be located lower than the pump position to prevent air in the suction line.

## 8. Drain Piping

Install drain piping according to the chart and ensure that pressure within the pump housing should be maintained at a normal pressure of less than 0.1 MPa (14.5 PSI) and surge pressure of less than 0.5 MPa (72.5 PSI).

Length of piping should be less than 1 m (3.3 ft.), and the pipe end should be submerged in oil.

### [Recommended Drain Piping Size]

#### (Single Pump & Variable/Fixed Double Pump)

Model	Fitting Size	Inside Dia. of Pipe
A10, A16, A16R1 A22, A22R1	3/8 [Inside Dia. 8.5 mm (.33 in.) or more]	10 mm (.39 in.)
A37, A37R1	1/2 [Inside Dia. 12 mm (.47 in.) or more]	12 mm (.47 in.)
A56, A56R1 A70, A70R* A90, A90R* A145, A145R*	3/4 [Inside Dia. 16 mm (.63 in.) or more]	19 mm (.75 in.)

#### (Double Pump)

Refer to the suitable single pump as shown below.

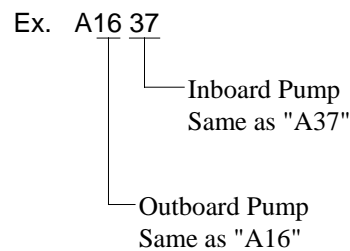

- Fix drain pipe for each side of the pump.

## 9. Bleeding Air

It may be necessary to bleed air from pump case and outlet line to remove causes of vibration. An air bleed valve (Model No. ST1004-\* -10\*, Catalogue No.: Pub. EC-3001) is recommended for this purpose.

## 10. Starting

Before first starting, fill pump case with clean operating oil via the fill port.

In order to avoid air blockage when first starting, adjust the control valves so that the discharged oil from the pump is returned direct to the tank or the actuator moves in a free load.

### [Volume of Pre-fill Oil Required] (Single Pump)

Model	Volume cm <sup>3</sup> (in. <sup>3</sup> )
A10	370 (22.6)
A16/A22	600 (36.6)
A37/A56	1200 (73.2)
A70	2100 (128)
A90	2500 (153)
A145	3300 (201)

### (Double Pump)

Model	Volume cm <sup>3</sup> (in. <sup>3</sup> )	
	Outboard Pump	Inboard Pump
A1616	600 (36.6)	650 (40.0)
A1622	600 (36.6)	650 (40.0)
A2222	600 (36.6)	
A1637	600 (36.6)	1250 (76.3)
A2237	600 (36.6)	
A1656	600 (36.6)	1250 (76.3)
A2256	600 (36.6)	
A3756	1200 (73.2)	
A1670	600 (36.6)	2180 (133)
A2270	600 (36.6)	
A3770	1200 (73.2)	
A1690	600 (36.6)	2580 (157)
A2290	600 (36.6)	
A3790	1200 (73.2)	
A5690	1200 (73.2)	
A16145	600 (36.6)	3380 (206)
A22145	600 (36.6)	
A37145	1200 (73.2)	
A56145	1200 (73.2)	

### (Variable/Fixed Double Pump)

Model	Volume cm <sup>3</sup> (in. <sup>3</sup> )
A16R1/A22R1	650 (40.0)
A37R1/A56R1	1250 (76.3)
A70R1/A70R2	2180 (133)
A90R1/A90R2	2580 (157)
A145R1/A145R2	3380 (206)

## 11. Setting Discharge Pressure and Delivery

At the time of shipment, the unit has been preset to maximum delivery and minimum discharge pressure.

Adjust the preset delivery and pressure to meet your system requirements.

### ● Adjustment of Discharge Pressure

Turning the adjustment screw clockwise, increases pressure.

### [Volume adjusted by each full turn of the pressure adjustment screw]

Model Numbers	Adjustment Volume MPa (PSI)
A10-FR01B	2.9 (420)
A10-FR01C/H	5.4 (780)
A16/A22/A37/A56-*-R-01-B	3.5 (510)
A16/A22/A37/A56-*-R-01-C	6.5 (940)
A16/A37/A56-*-R-01-H	7.9 (1150)
A70/A90/A145-*-R01B	2.3 (330)
A70/A90/A145-*-R01C	3.2 (460)
A70/A90/A145-*-R01H	4.0 (580)
A70/A90/A145-*-R01K	4.7 (680)
A*-*-R-02	5.0 (730)

### ● Adjustment of Delivery

Turning the flow adjustment screw clockwise, decreases delivery.

### [The minimum adjustable flow and adjustable volume of each full turn of the delivery adjustment screw]

Model Numbers	Adjustable volume with each full turn of the adjustment screw cm <sup>3</sup> /rev (cu.in./rev)	Minimum adjustment flow cm <sup>3</sup> /rev (cu.in./rev)
A10	1.1 (.067)	2.0 (.122)
A16	1.4 (.085)	4.0 (.244)
A22	2.0 (.122)	6.0 (.366)
A37	2.9 (.177)	10 (.610)
A56	3.9 (.238)	12 (.732)
A70	4.4 (.268)	30 (1.83)
A90	4.8 (.293)	56 (3.42)
A145	7.2 (.439)	83 (5.06)

■ Control Type

● Single Pumps

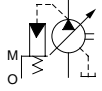
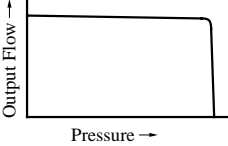
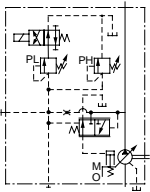
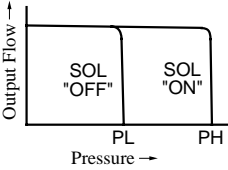
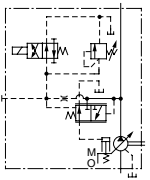
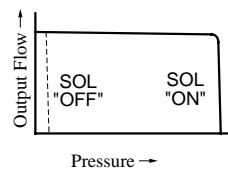
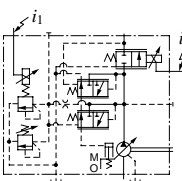
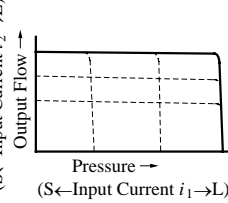
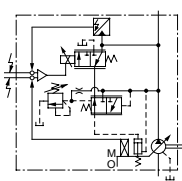
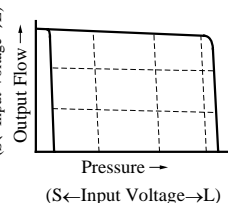
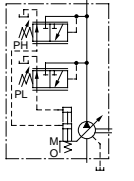
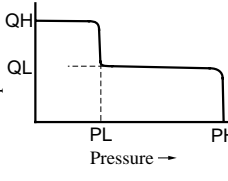
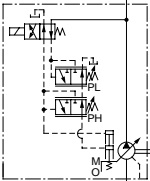
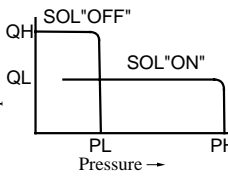
Control Type	Graphic Symbols	Performance Characteristics	Explanation	Page
"01" Pressure Compensator Type			When the system pressure increases and comes close to the preset cut-off pressure, the pump flow decreases automatically while maintaining the set pressure as it is.	6
"02" Solenoid-two Pressure Control Type			This type of control is ideal for an application where the output power of the actuator has to be controlled in two different load pressures while keeping the actuator speed nearly constant.	28
"03" Pressure Compensator with Unloading Type			It is suitable for a situation where a long unloading time is required and heat generation and noise have to be kept at their lowest levels. <ul style="list-style-type: none"><li>• The pump can be used in combination with the multistage pressure control valve.</li></ul>	36
"04" Proportional Electro-Hydraulic Load Sensing Type			This is an energy-saving type control which regulates the pump flow and load pressure to be at absolute minimum necessary level to operate the actuator. Pump flow rate and cut-off pressure are controlled proportional to the input current to the control device on the pump and the input current is regulated by the specific amplifier.	37
"04E" Proportional Electro-Hydraulic Pressure & Flow Control Type			This type of control has the pressure sensor and tilt angle sensor in the pump. The pump is used with the external amplifier. Flow and pressure can be controlled in proportion to input voltage by only one control valve. The features has been greatly improved by electrical feedback of swash plate tilt angle correspond to flow rate and load pressure to control valve. <ul style="list-style-type: none"><li>• Linearity of input characteristics is excellent and easy to set.</li><li>• Hysteresis is lower, repeatability and reproducibility are fine.</li></ul>	47
"05" Two-Pressure Two-Flow Control Type by System Pres.			This type of control is suitable for an application like "Presses" where the changeover from rapid advance to feed is required just when the pressing (pressurizing) starts.	—*
"06" Two-Pressure Two-Flow Control Type by Solenoid Valve			This pump control is suitable for machining found on machine tool, where machining starts after the changeover from rapid advance, to feed has been made.	—*

### Control Type

#### Control Type

##### Single Pumps

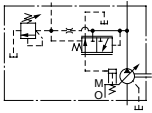
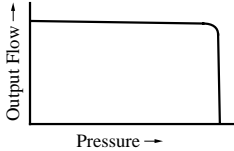
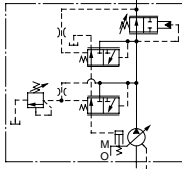
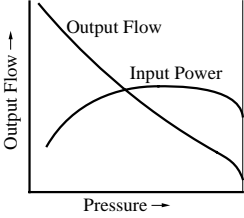
Control Type	Graphic Symbols	Performance Characteristics	Explanation	Page
"07" Pilot Pressure Control Type Pressure Compensator			The pump is used in combination with the pilot relief valve or multistage pressure control valve. By controlling the pilot pressure, the full cut-off pressure can be remote-controlled according to your requirements.	58
"09" Constant Power Control Type			<ul style="list-style-type: none"> <li>• Pump input power can be controlled in accordance with the motor output.</li> <li>• When the discharge pressure rise, the output flow decreases corresponding to the preset input power.</li> <li>• The pump can act for function of 2 pumps, low-pressure large-flow and high-pressure small-flow. Therefore, the motor capacity can be reduced.</li> </ul>	—*

\* Control type "05", "06" and "09" are not shown in this catalogue. Contact us for the details.

#### Availability of Control Type

Mark "○" in the table below refers to standard model.

##### Single Pumps

Model Number	Geometric Displacement cm <sup>3</sup> /rev (cu.in./rev)	Control Type									
		01	02	03	04	04E	05	06	07	09	
A10	10.0 (.610)	○								○	
A16	15.8 (.964)	○	○	○	○	○	○	○	○	○	○
A22	22.2 (1.355)	○	○	○	○	○		○	○		
A37	36.9 (2.25)	○	○	○	○	○	○	○	○	○	○
A56	56.2 (3.43)	○	○	○	○	○	○	○	○	○	○
A70	70.0 (4.27)	○	○	○	○	○		○	○	○	
A90	91.0 (5.55)	○	○	○	○	○		○	○	○	
A145	145 (8.85)	○	○	○	○	○		○	○	○	

##### Double Pump & Variable/Fixed Double Pump

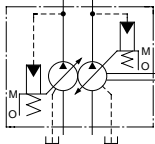
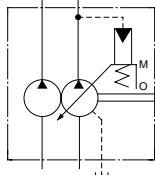
Control Type	Graphic Symbols	Explanation	Page
"01/01" Pressure Compensator Type		These double pump consist of two "A" series single pumps combined in tandem and driven by a common shaft. Fluid delivered from two separate ports can be either supplied to separate or common circuit according to the usage.	67
"01" Pressure Compensator + Fixed Vane Pump		These double pump consist of "A" series pumps and PV2R series vane pumps combined in tandem and driven by a common shaft. Fluid delivered from two separate ports can be either supplied to separate or common circuit according to the usage.	80



**Specifications**

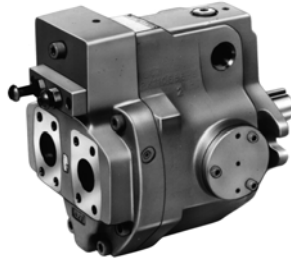

Graphic Symbol

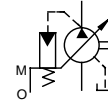

**Specifications**

Model Numbers	Geometric Displacement cm <sup>3</sup> /rev (cu. in. /rev)	Minimum Adj. Flow cm <sup>3</sup> /rev (cu. in. /rev)	Operating Pres. MPa (PSI)		Shaft Speed Range r/min		Approx. Mass kg (lbs.)	
			Rated <sup>*2</sup>	Intermittent <sup>*1</sup>	Max.	Min.	Flange Mtg.	Foot Mtg.
A10-FR01B-12*	10.0 (.610)	2 (.122)	16 (2320)	21 (3050)	1800	600	5.1 (11.2)	—
A10-FR01C/H-12*							8.5 (18.7)	
A16-*-R-01-*-K-32*	15.8 (.964)	4 (.244)	16 (2320)	21 (3050)	1800	600	16.5 (36.4)	18.7 (41.2)
A22-*-R-01-*-K-32*	22.2 (1.355)	6 (.366)	16 (2320)	16 (2320)	1800	600	16.5 (36.4)	18.7 (41.2)
A37-*-R-01-*-K-32*	36.9 (2.25)	10 (.610)	16 (2320)	21 (3050)	1800	600	28.0 (61.7)	32.3 (71.2)
A56-*-R-01-*-K-32*	56.2 (3.43)	12 (.732)	16 (2320)	21 (3050)	1800	600	35.0 (77.2)	39.3 (86.7)
A70-*-R01*S-60*	70.0 (4.27)	30 (1.83)	25 (3630)	28 (4060)	1800	600	58.5 (129)	70.5 (155)
A90-*-R01*S-60*	91.0 (5.55)	56 (3.42)	25 (3630)	28 (4060)	1800	600	72.5 (160)	93 (205)
A145-*-R01*S-60*	145 (8.85)	83 (5.06)	25 (3630)	28 (4060)	1800	600	92.5 (204)	117.5 (259)

★1. Whenever setting pressure, make sure the full cut-off pressure never exceeds the maximum intermittent pressure.

★2. Care should be taken in cases of used at a higher pressure than the rated pressure, because operating terms may be restricted. For example, if used as per maximum illustrated operating conditions, intermittent time at maximum flow is restricted to under 1/5 of one cycle time and under 6 seconds simultaneously. Conditions may vary according to the actual working pressure and delivery (inclination angle of the swash plate). Consult factory or Yuken sales representative for further information.

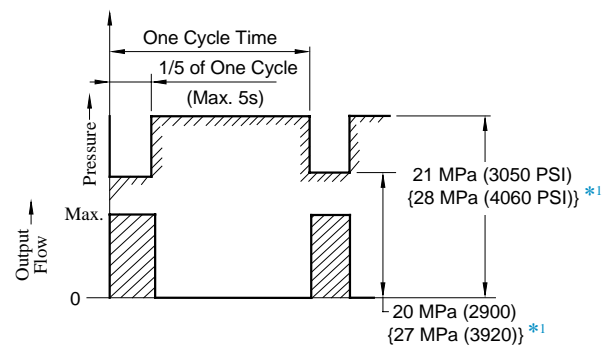

\*1. Applicable only for "A70/90/145"

#### ■ Model Number Designation

A16	-F	-R	-01	-B	-S	-K	-32	*
Series Number	Mounting	Direction of Rotation	Control Type	Pres. Adj. Range MPa (PSI)	Port Position	Shaft Extension	Design Number	Design Std.
A16 (15.8 cm <sup>3</sup> /rev)	F: Flange Mtg.  L: Foot Mtg.	(Viewed from Shaft End)  R: Clockwise (Normal) <small>*1</small>	01: Pressure Compensator Type	B: 1.2 - 7 (170 - 1020) C: 1.2 - 16 (170 - 2320) H: 1.2 - 21 (170 - 3050)	None: Axial Port  S: Side Port <small>*2</small>	K: Keyed Shaft	32	Refer to <small>*3</small>
A22 (22.2 cm <sup>3</sup> /rev)				B: 1.2 - 7 (170 - 1020) C: 1.2 - 16 (170 - 2320)			32	
A37 (36.9 cm <sup>3</sup> /rev)				B: 1.2 - 7 (170 - 1020) C: 1.2 - 16 (170 - 2320) H: 1.2 - 21 (170 - 3050)			32	
A56 (56.2 cm <sup>3</sup> /rev)				B: 1.2 - 7 (170 - 1020) C: 1.2 - 16 (170 - 2320) H: 1.2 - 21 (170 - 3050)			32	

A70	-F	R	01	B	S	-60	*
Series Number	Mounting	Direction of Rotation	Control Type	Pres. Adj. Range MPa (PSI)	Port Position	Design Number	Design Std.
A10 (10.0 cm <sup>3</sup> /rev)	F: Flange Mtg. <small>*1</small>	(Viewed from Shaft End)  R: Clockwise (Normal) <small>*1</small>	01: Pressure Compensator Type	B: 1.2 - 7 (170 - 1020) C: 2.0 - 16 (290 - 2320) H: 2.0 - 21 (290 - 3050)	—	12	Refer to <small>*3</small>
A70 (70.0 cm <sup>3</sup> /rev)	F: Flange Mtg.			B: 1.2 - 7 (170 - 1020) C: 1.5 - 16 (220 - 2320) H: 1.8 - 21 (260 - 3050) K: 2.0 - 28 (290 - 4060)	S: Side Port	60	
A90 (91.0 cm <sup>3</sup> /rev)	L: Foot Mtg.			60			
A145 (145 cm <sup>3</sup> /rev)	L: Foot Mtg.			60			

★ 1. Available to supply pump with anti-clockwise rotation. Consult Yuken for details.

★ 2. The axial port is not available to the N.American Design Standard of A37 and A56.

★ 3. Design Standards: None ..... Japanese Standard "JIS"  
80 ..... European Design Standard  
90 ..... N. American Design Standard

★ 4. When A10 pump is used as the foot Mtg., order the Mtg. Bracket kit shown below separately. Refer to page 17 for dimensions of the Mtg. bracket.

Note: The mounting bracket kit consists of a mounting bracket, 2 hex. bolts and 2 plain washer.

Mtg. Bracket Kit Numbers	Approx. Mass kg (lbs.)
LP-1A-10	2.2 (4.9)

#### ■ Pipe Flange Kits

Pipe flange kits are available. When ordering, specify the kit number from the table below.

Pump Model Numbers	Name of Port	Pipe Flange Kit Numbers						
		Threaded Connection			Socket Welding <sup>*</sup>		Butt Welding	
		Japanese Std. "JIS"	European Design Std.	N. American Design Std.	Japanese Std. "JIS" European Design Std.	N. American Design Std.	Japanese Std. "JIS" European Design Std.	N. American Design Std.
A16-*-R-01 A22-*-R-01	Suction	F5-06-A-10	F5-06-A-1080	F5-06-A-1090	F5-06-B-10	F5-06-B-1090	F5-06-C-10	F5-06-C-1090
	Discharge	F5-06-A-10	F5-06-A-1080	F5-06-A-1090	F5-06-B-10	F5-06-B-1090	F5-06-C-10	F5-06-C-1090
A37-*-R-01 A56-*-R-01	Suction	F5-10-A-10	F5-10-A-1080	F5-10-A-1090	F5-10-B-10	F5-10-B-1090	F5-10-C-10	F5-10-C-1090
	Discharge	F5-10-A-10	F5-10-A-1080	F5-10-A-1090	F5-10-B-10	F5-10-B-1090	F5-10-C-10	F5-10-C-1090
A70-*R01	Suction	F5-12-A-10	F5-12-A-1080	F5-12-A-1090	F5-12-B-10	F5-12-B-1090	F5-12-C-10	F5-12-C-1090
	Discharge	F5-08-A-10	F5-08-A-1080	F5-08-A-1090	F5-08-B-10	F5-08-B-1090	F5-08-C-10	F5-08-C-1090
A90-*R01 A145-*R01	Suction	F5-16-A-10	F5-16-A-1080	F5-16-A-1090	F5-16-B-10	F5-16-B-1090	F5-16-C-10	F5-16-C-1090
	Discharge	F5-10-A-10	F5-10-A-1080	F5-10-A-1090	F5-10-B-10	F5-10-B-1090	F5-10-C-10	F5-10-C-1090

★ In case of using socket welding flanges, there is a case where the operating pressure should be set lower than the normal because of strength of the flanges. Therefore, please pay cautious attention to the operating pressure when the socket welding flanges are used.

• Details of the pipe flange kits are given in the Catalogue No. Pub. EC-3001

Response Characteristics Change in Accordance with Circuits and Operating Conditions.

#### Test Circuit and Conditions

##### ● Circuit

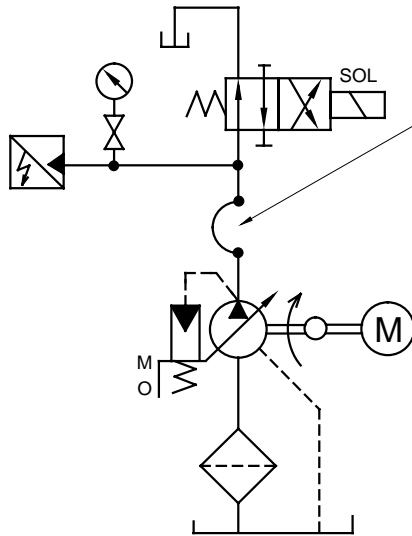

##### ● Conditions

Drive Speed : 1500 r/min  
 Hydraulic Fluid : ISO VG32 oil  
 Oil Temperature : A10-A56: 50 °C (122 °F) [Viscosity 20 mm<sup>2</sup>/s (100 SSU)]  
 A70-A145: 40 °C (104 °F) [Viscosity 32 mm<sup>2</sup>/s (150 SSU)]

##### High Pressure Rubber Hose

Model	Ruber Hose Size
A10	1/2" × 800 mm (2.6 ft.)
A16 A22	3/4" × 700 mm (2.3 ft.)
A37 A56	3/4" × 2000 mm (6.6 ft.)
A70	3/4" × 3500 mm (11.5 ft.)
A90 A145	3/4" × 3000 mm (9.8 ft.) + 1-1/4" × 2000 mm (6.6 ft.)

#### Result of Measurement

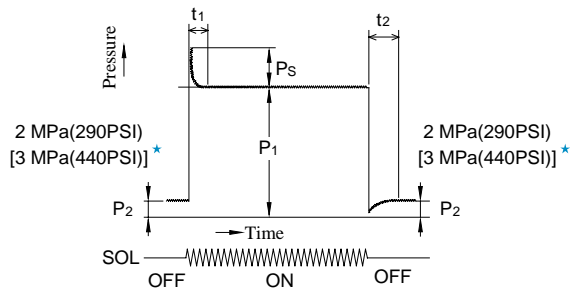

★ Applicable only for "A90/A145"

Model	Full Cut-off Pressure P <sub>1</sub> MPa (PSI)	Response Time ms		Overshoot Pressure P <sub>s</sub> MPa (PSI)
		t <sub>1</sub>	t <sub>2</sub>	
A10	21 (3050)	100	75	2.6 (380)
A16	16 (2320)	38*	59*	3.6 (520)
A22	16 (2320)	30*	72*	5.9 (860)
A37	16 (2320)	40*	78*	7.8 (1130)
A56	16 (2320)	38*	88*	7.6 (1100)
A70	25 (3630)	80	100	7.8 (1130)
A90	25 (3630)	90	110	7.9 (1150)
A145	25 (3630)	100	150	8.8 (1280)

\* Response time except A10, A70, A90 and A145 is measured Yoke travel.

**Typical Pump Characteristics**

Typical Performance Characteristics of Type "A10" at Viscosity 20 mm<sup>2</sup>/s (100 SSU) [ISO VG32 Oils, 50°C (122°F)]

**Performance Characteristic Curve**

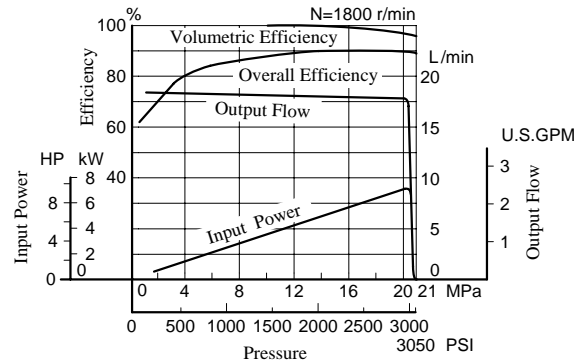
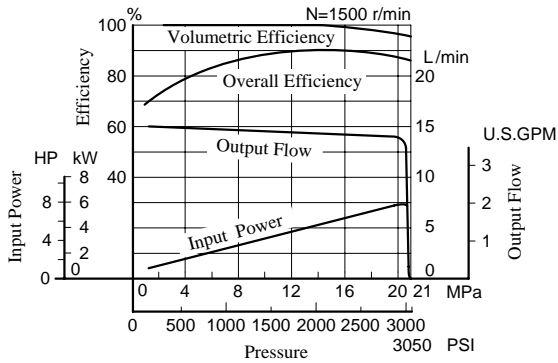

**Input Power**

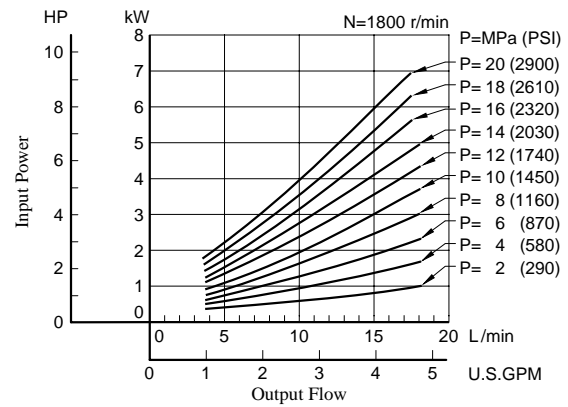
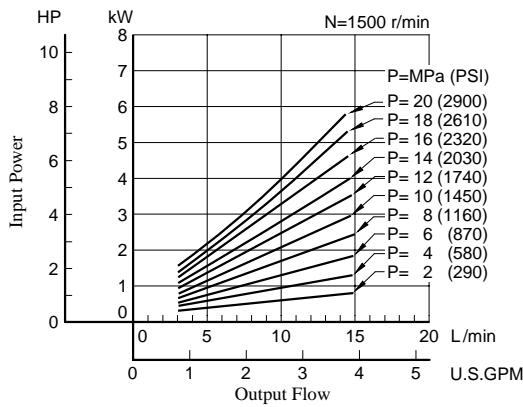

**Full Cut-off Power**

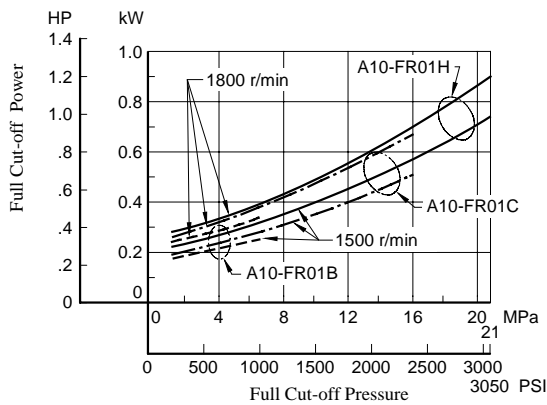

**Drain**

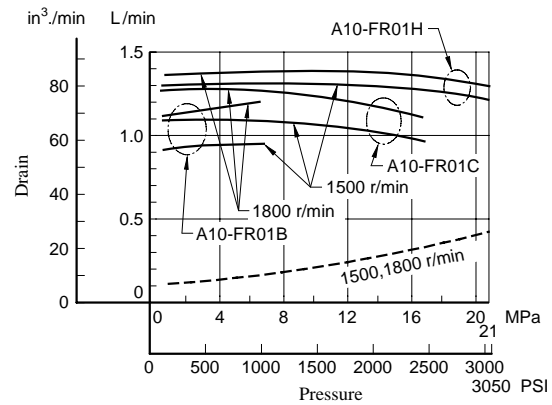

**Noise Level [One metre (3.3 ft.) horizontally away from pump head cover]**

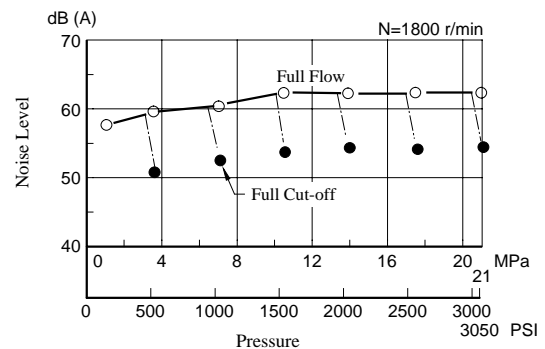
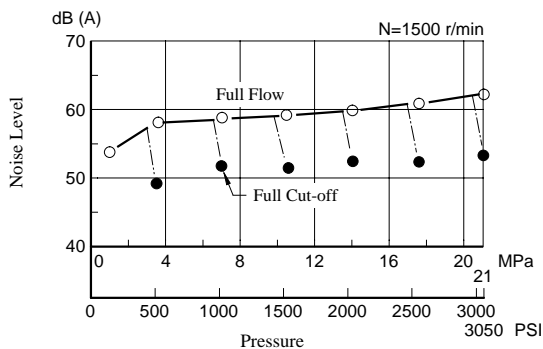

Typical Performance Characteristics of Type "A16" at Viscosity 20 mm<sup>2</sup>/s (100 SSU) [ISO VG32 Oils, 50°C (122°F)]

#### Performance Characteristic Curve

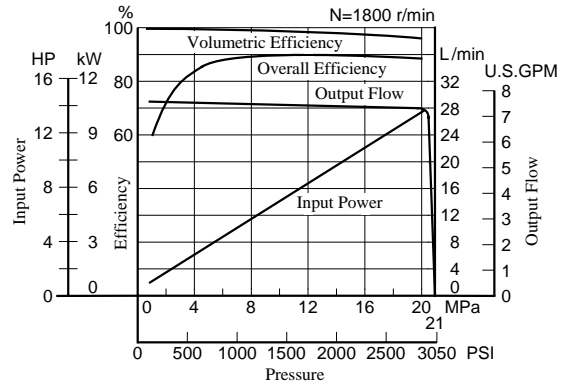
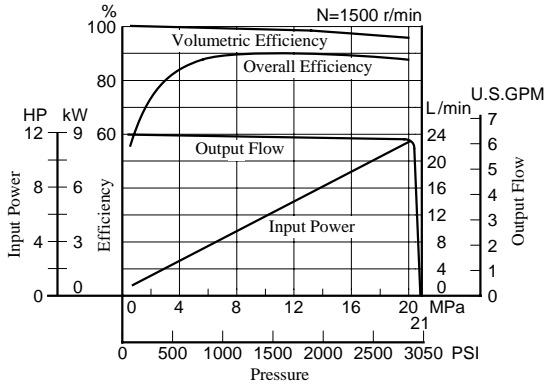

#### Input Power

Example: At a pressure of under 10 MPa (1450 PSI), a flow 20 L/min (5.3 U.S.GPM), and rotation 1500 r/min, the axial input becomes about 3.7 kW (5 HP) as shown the dotted line in the graph.

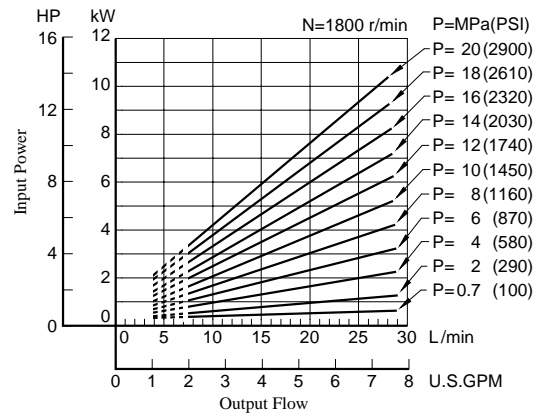
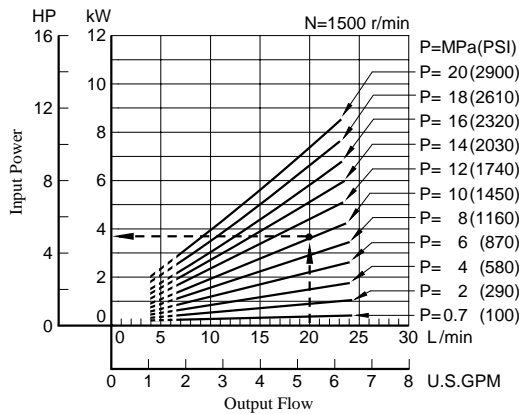

#### Full Cut-off Power

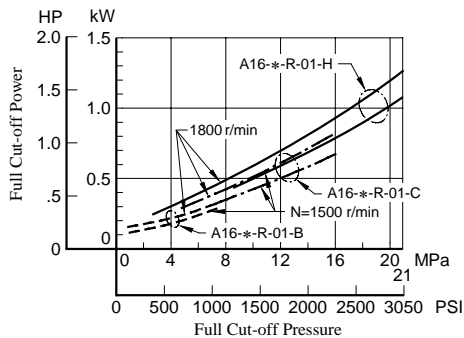

#### Drain

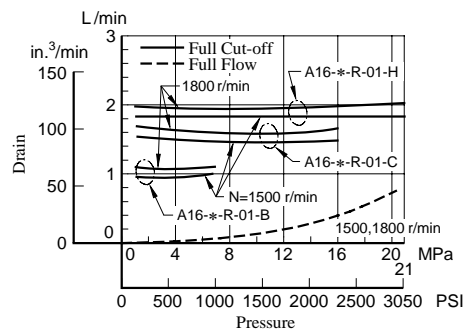

#### Noise Level [One metre (3.3 ft.) horizontally away from pump head cover

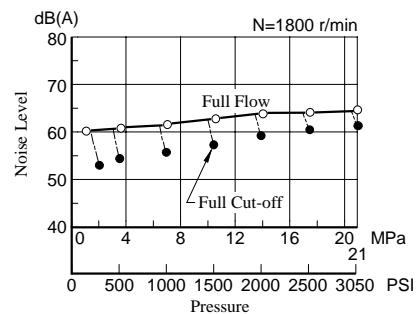
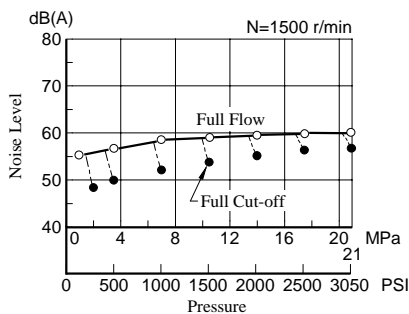

### Typical Pump Characteristics

Typical Performance Characteristics of Type "A22" at Viscosity 20 mm<sup>2</sup>/s (100 SSU) [ISO VG32 Oils, 50°C (122°F)]

#### Performance Characteristic Curve

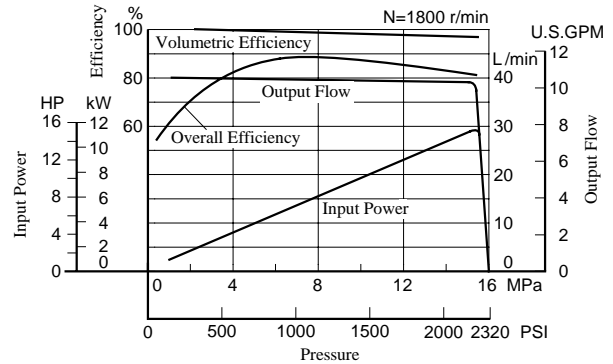
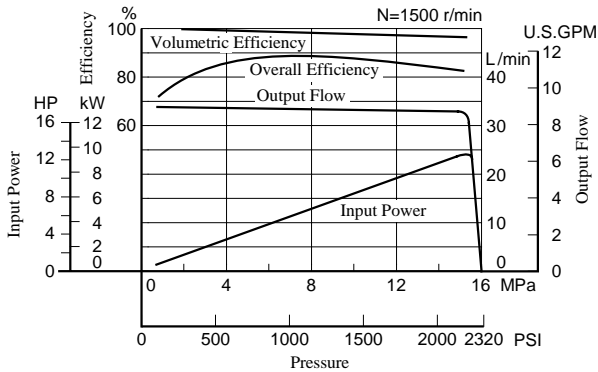

#### Input Power

Example: At a pressure of under 10 MPa (1450 PSI), a flow 30 L/min (7.9 U.S.GPM), and rotation 1500 r/min, the axial input becomes about 5.4 kW (7.2 HP) as shown the dotted line in the graph.

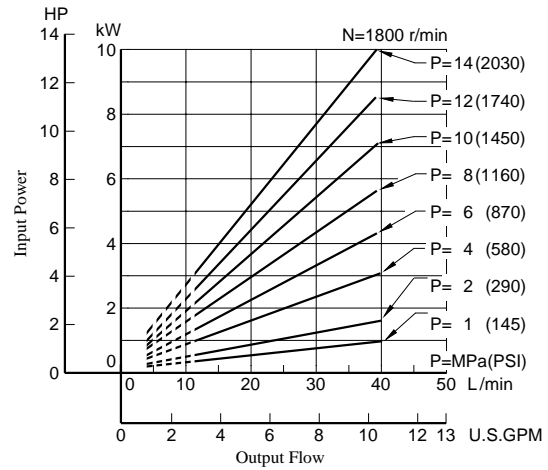
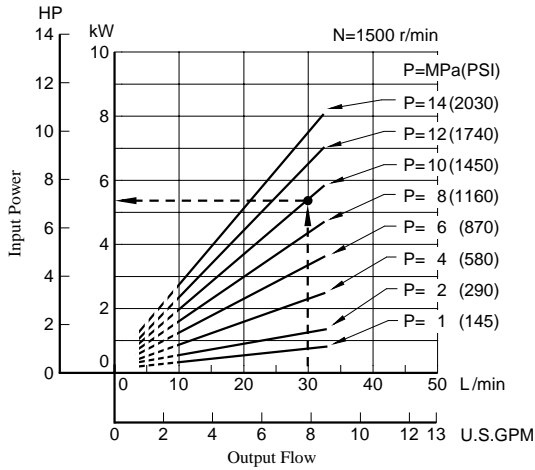

#### Full Cut-off Power

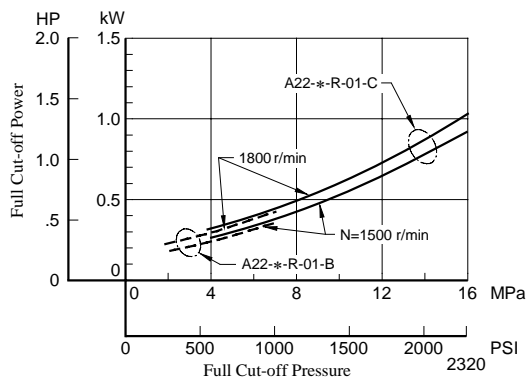

#### Drain

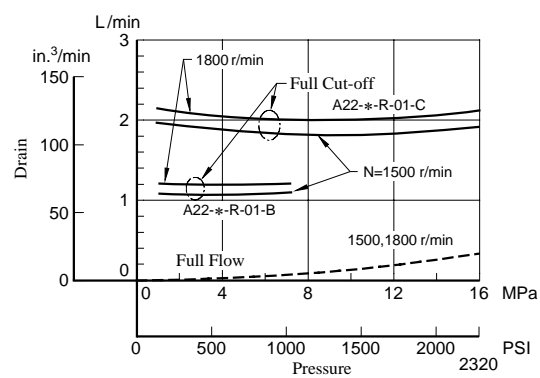

#### Noise Level [One metre (3.3 ft.) horizontally away from pump head cover]

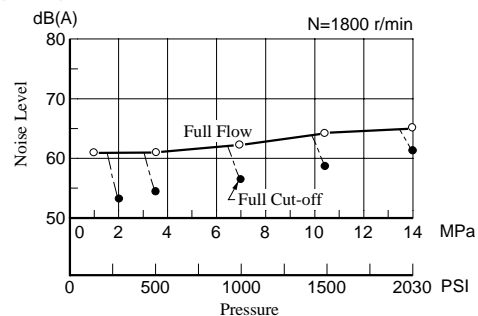
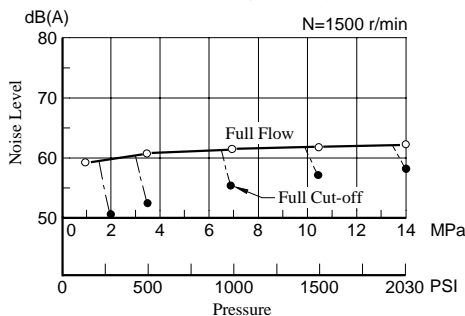

Typical Performance Characteristics of Type "A37" at Viscosity 20 mm<sup>2</sup>/s (100 SSU) [ISO VG32 Oils, 50°C (122°F)]

#### Performance Characteristic Curve

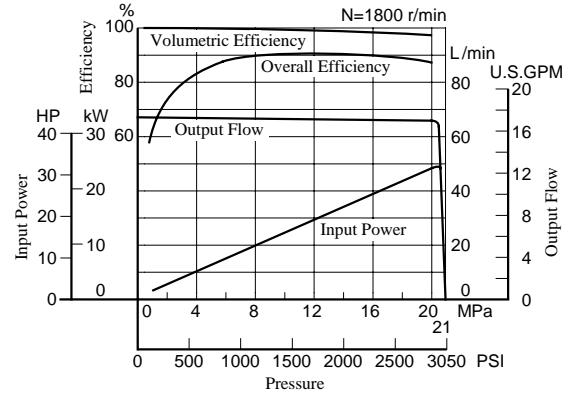
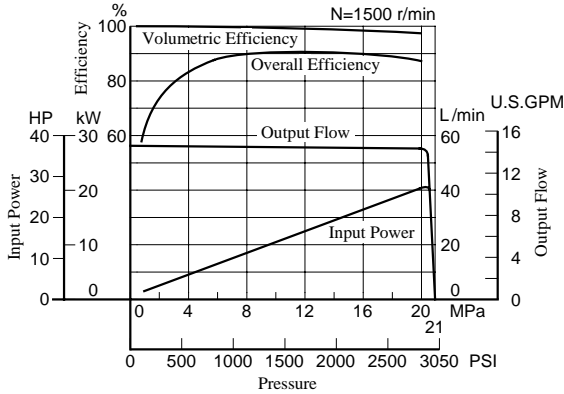

#### Input Power

Example: At a pressure of under 16 MPa (2320 PSI), a flow 45 L/min (11.9 U.S.GPM), and rotation 1500 r/min, the axial input becomes about 12.6 kW (16.9 HP) as shown the dotted line in the graph.

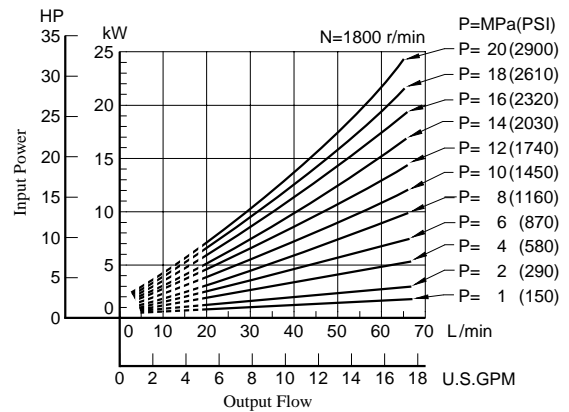
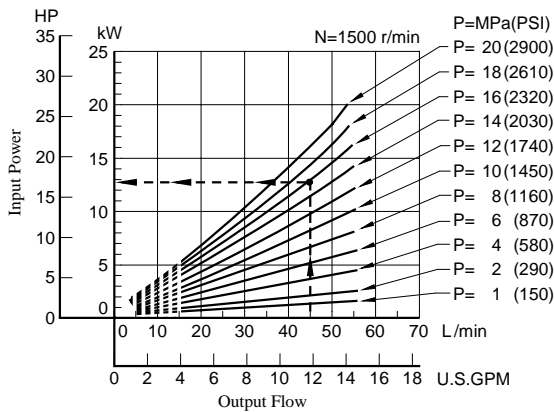

#### Full Cut-off Power

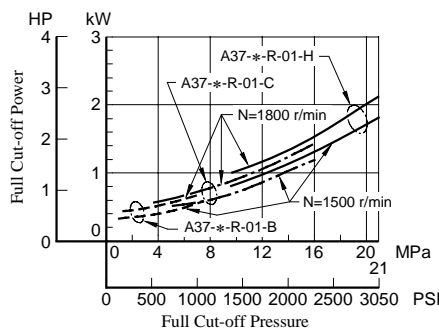

#### Drain

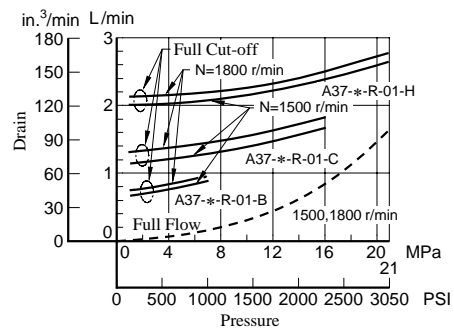

#### Noise Level [One metre (3.3 ft.) horizontally away from pump head cover]

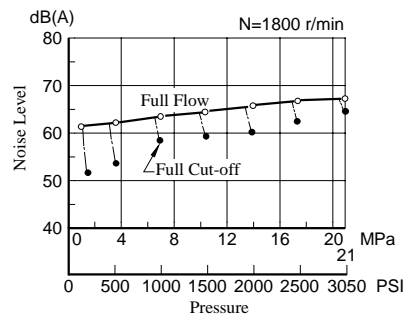
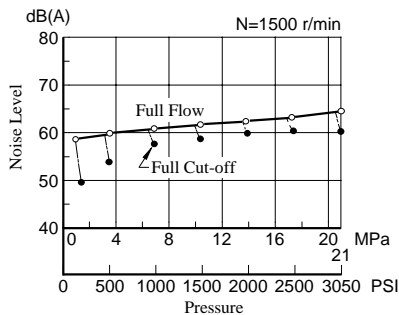

### Typical Pump Characteristics

Typical Performance Characteristics of Type "A56" at Viscosity 20 mm<sup>2</sup>/s (100 SSU) [ISO VG32 Oils, 50°C (122°F)]

#### Performance Characteristic Curve

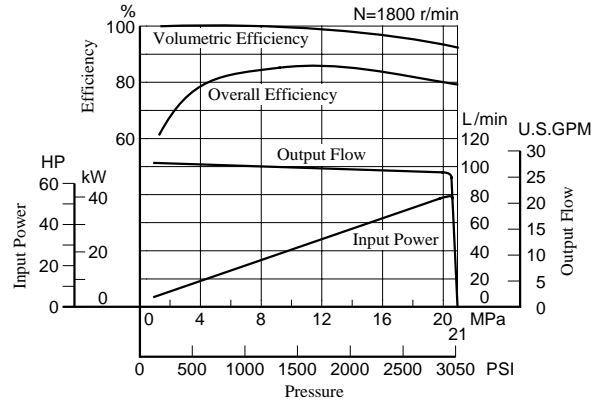
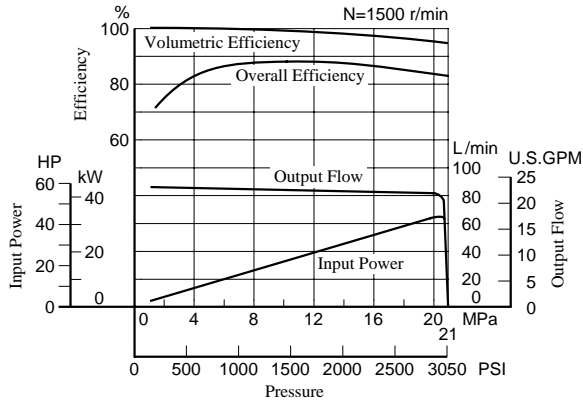

#### Input Power

Example: At a pressure of under 16 MPa (2320 PSI), a flow 70 L/min (18.5 U.S.GPM), and rotation 1500 r/min, the axial input becomes about 20.8 kW (27.9 HP) as shown the dotted line in the graph.

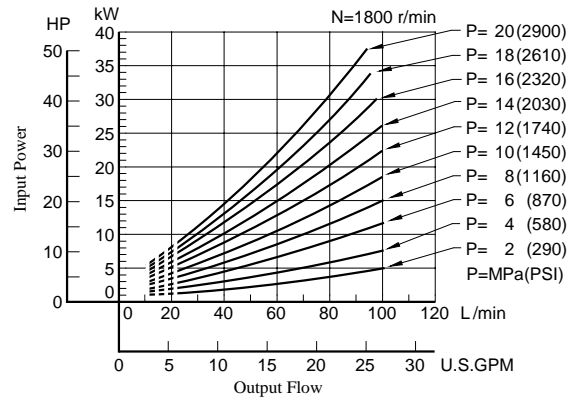
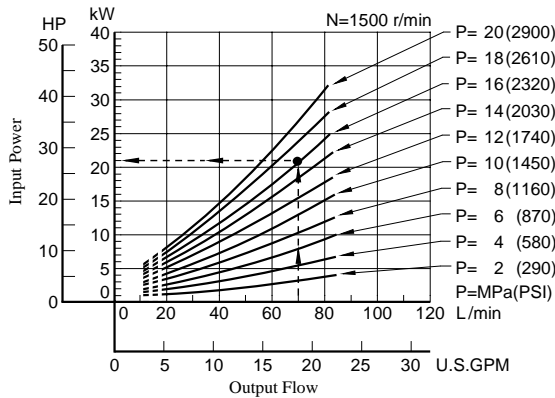

#### Full Cut-off Power

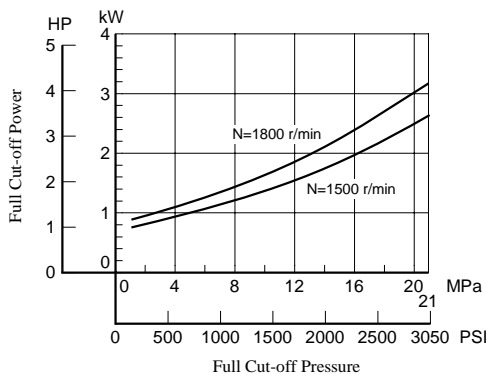

#### Drain

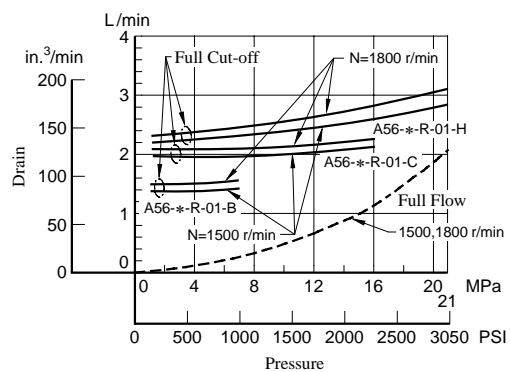

#### Noise Level [One metre (3.3 ft.) horizontally away from pump head cover]

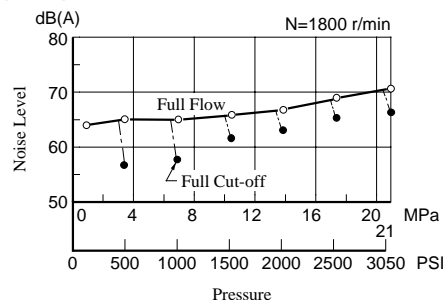
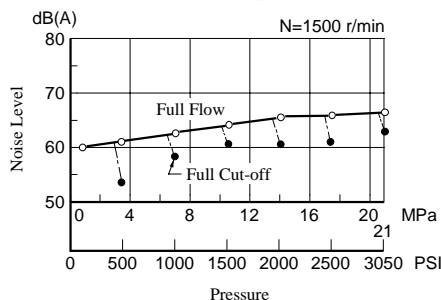



Typical Performance Characteristics of Type "A70" at Viscosity 32 mm<sup>2</sup>/s (150 SSU) [ISO VG32 Oils, 40°C (104°F)]

#### Performance Characteristics Curve

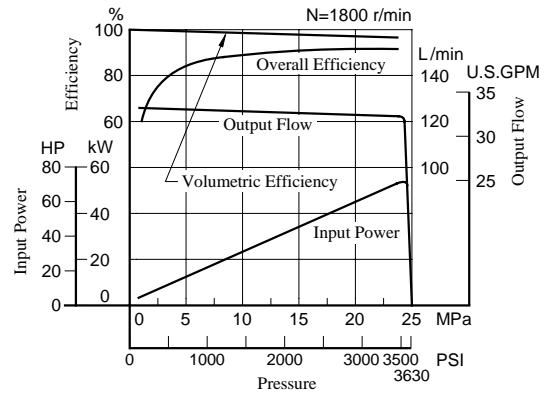
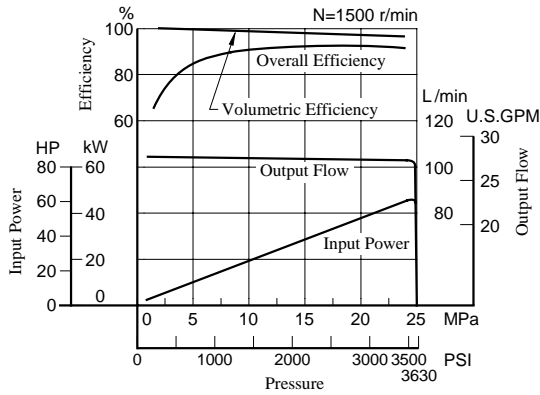

#### Input Power

Example: At a pressure of under 20 MPa (2900 PSI), a flow 70 L/min (18.5 U.S.GPM), and rotation 1500 r/min, the axial input becomes about 26 kW (35 HP) as shown the dotted line in the graph.

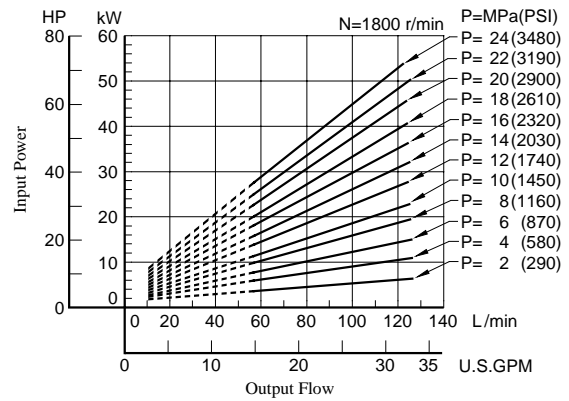
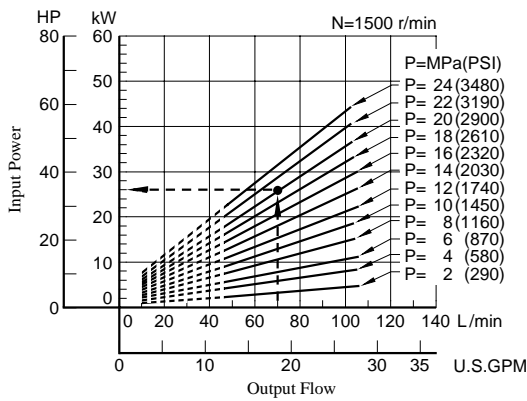

#### Full Cut-off Power

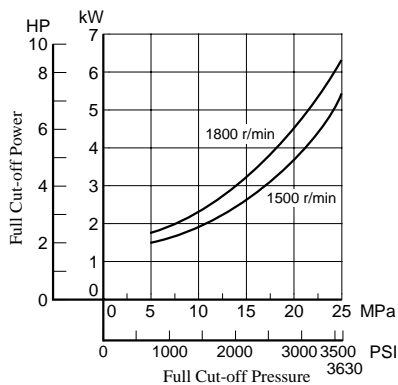

#### Drain

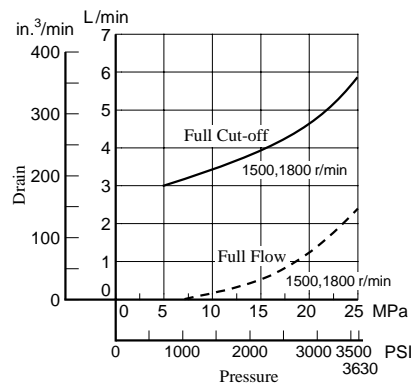

#### Noise Level [One metre (3.3 ft.) horizontally away from pump head cover]

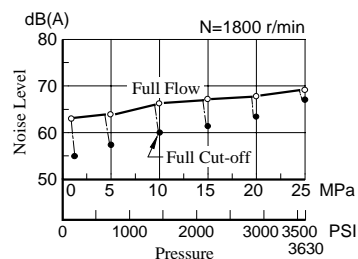
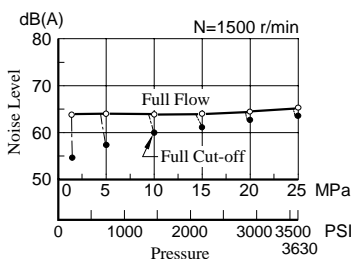

### Typical Pump Characteristics

Typical Performance Characteristics of Type "A90" at Viscosity 32 mm<sup>2</sup>/s (150 SSU) [ISO VG32 Oils, 40°C (104°F)]

#### Performance Characteristics Curve

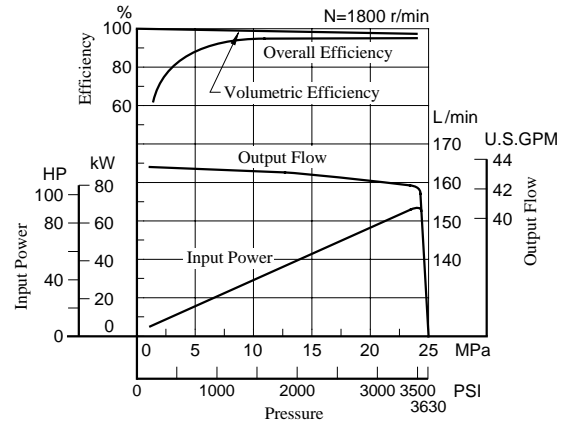
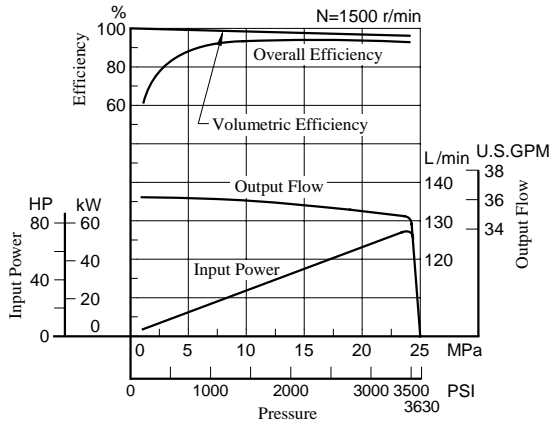

#### Input Power

Example: At a pressure of under 18 MPa (2610 PSI), a flow 110 L/min (29.1 U.S.GPM), and rotation 1500 r/min, the axial input becomes about 34 kW (46 HP) as shown the dotted line in the graph.

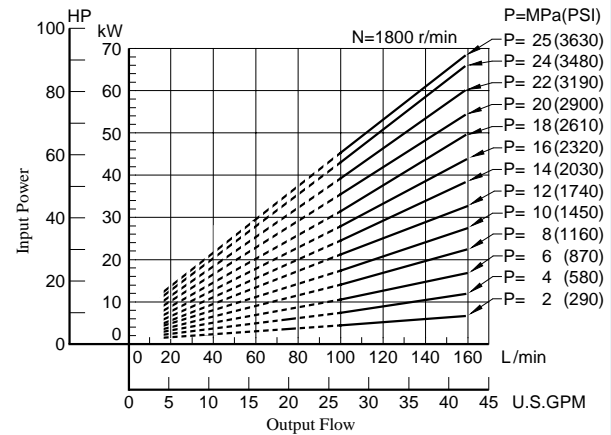
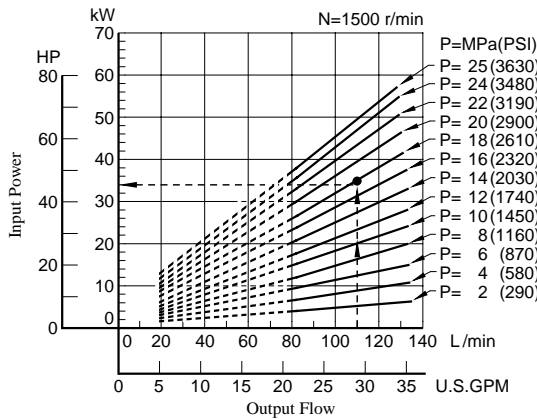

#### Full Cut-off Power

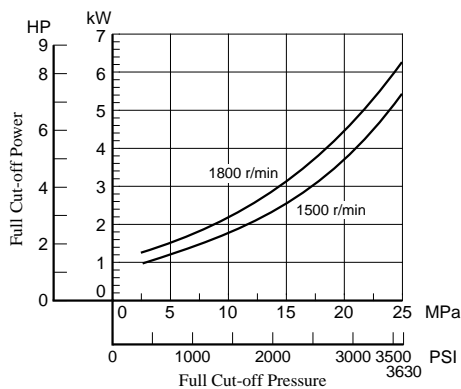

#### Drain

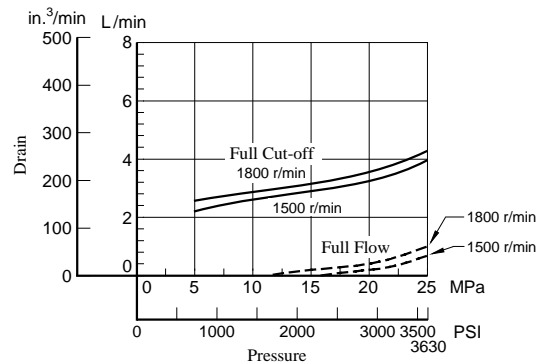

#### Noise Level [One metre (3.3 ft.) horizontally away from pump head cover]

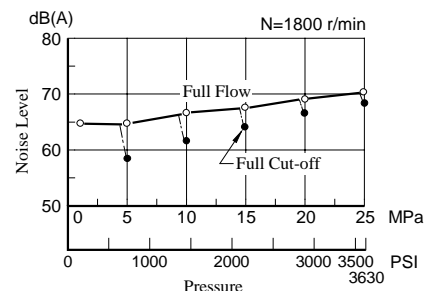
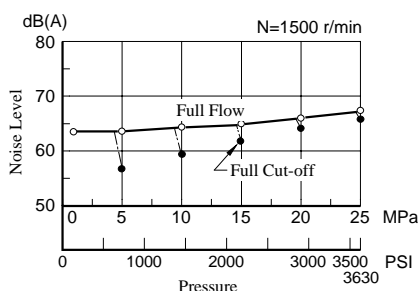

Typical Performance Characteristics of Type "A145" at Viscosity 32 mm<sup>2</sup>/s (150 SSU) [ISO VG32 Oils, 40°C (104°F)]

#### Performance Characteristics Curve

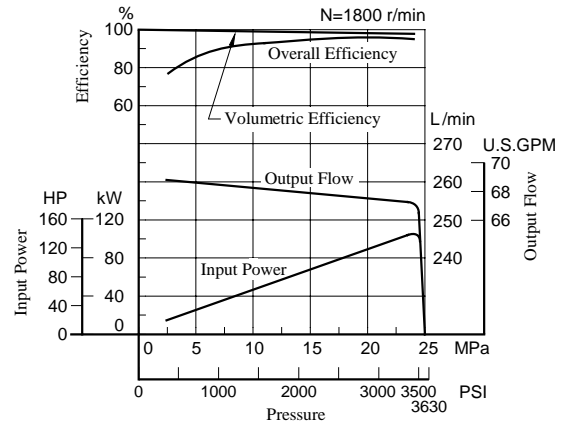
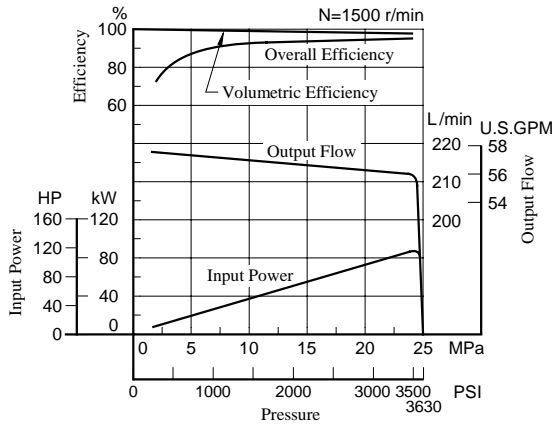

#### Input Power

Example: At a pressure of under 20 MPa (2900 PSI), a flow 180 L/min (47.6 U.S.GPM), and rotation 1500 r/min, the axial input becomes about 64 kW (86 HP) as shown the dotted line in the graph.

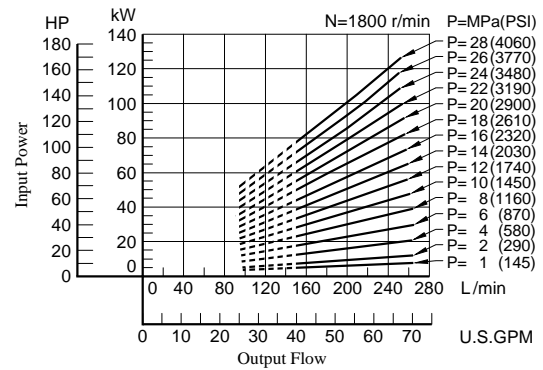
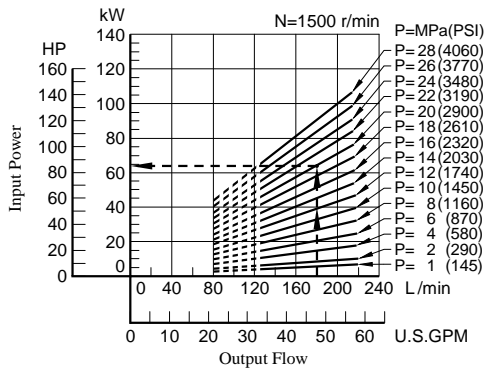

#### Full Cut-off Power

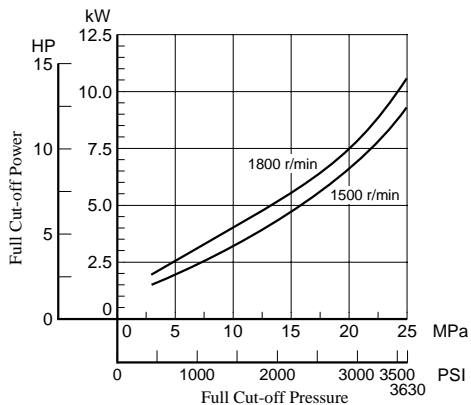

#### Drain

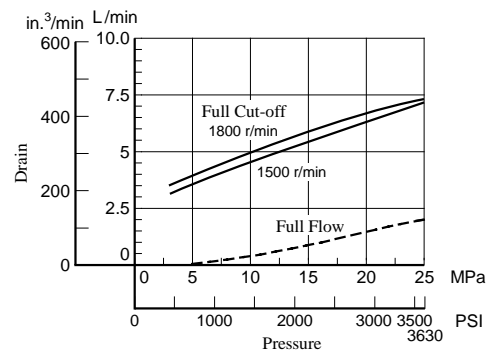

#### Noise Level [One metre (3.3 ft.) horizontally away from pump head cover]

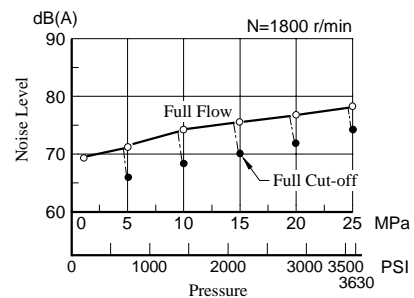
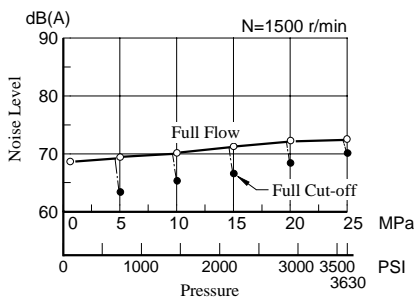

### Installation Drawing

Flange Mtg.: A10-FR01C-12/1280/1290  
A10-FR01H-12/1280/1290

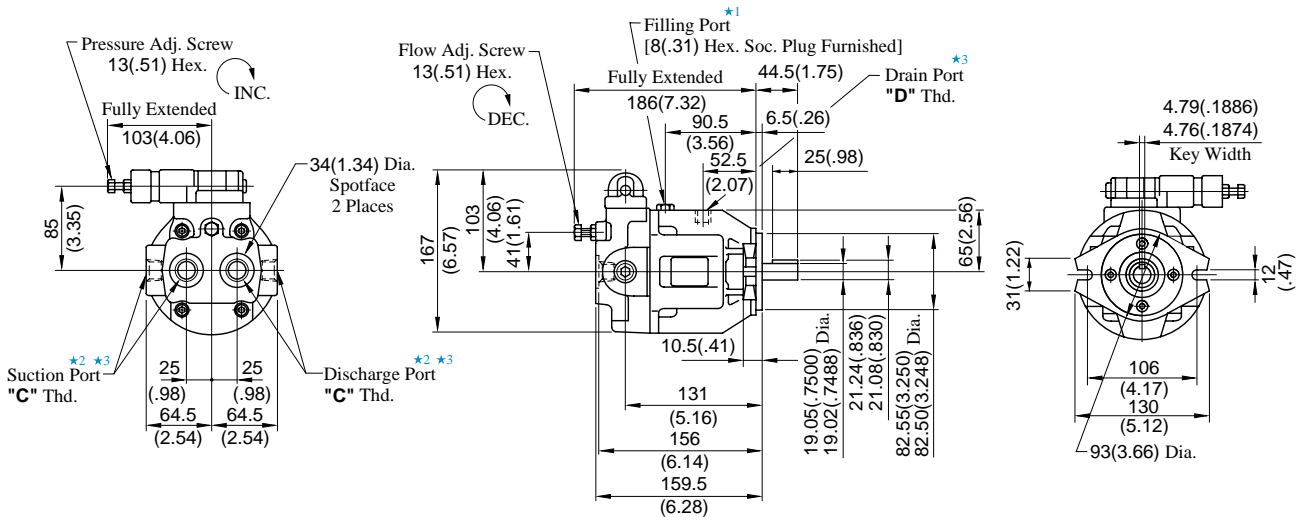

Model Numbers	Thread Size	
	"C" Thd.	"D" Thd.
A10-FR01*-12	Rc 1/2	Rc 3/8
A10-FR01*-1280	1/2 BSP.F	3/8 BSP.F
A10-FR01*-1290	1/2 NPT	3/8 NPT

- ★ 1. Install the pump so that the "Filling Port" is at the top.
- ★ 2. Use either port of two suction and discharge ports at your option. Keep the remaining ports plugged.
- ★ 3. As the tightening torques of suction, discharge and drain port fittings, conform to the below.

Model Numbers	Tightening Torque Nm(IN. lbs.)	
	Suction Port & Discharge Port	Drain Port
A10-FR01B-12/1290	65-75 (575-664)	40-50 (354-443)
A10-FR01C/H-12/1290	65-75 (575-664)	40-50 (354-443)
A10-FR01B-1280	98-108 (867-956)	39-43 (345-381)
A10-FR01C/H-1280	98-108 (867-956)	39-43 (345-381)

Flange Mtg.: A10-FR01B-12/1280/1290

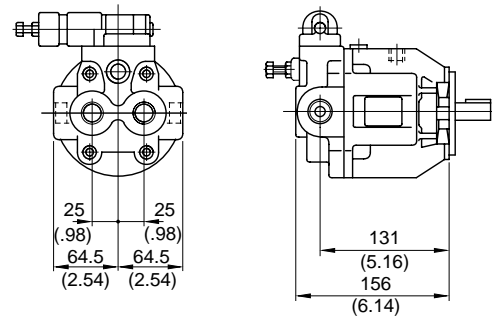

- For other dimensions, refer to above drawing.

DIMENSIONS IN  
MILLIMETRES (INCHES)

Mounting Bracket Kit: LP-1A-10

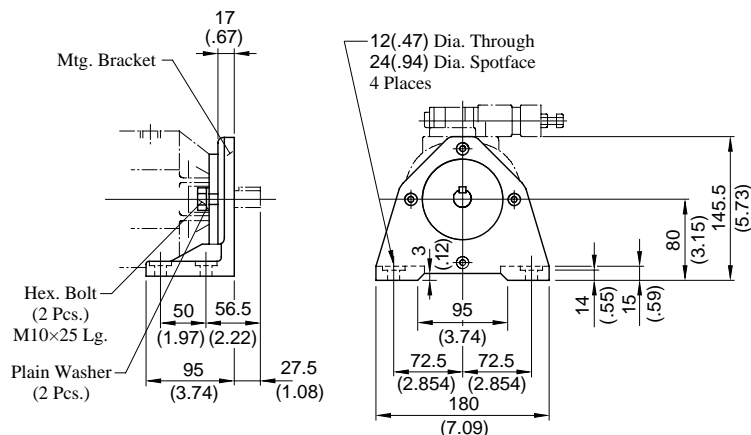

### Installation Drawing

#### Axial Port Type

Flange Mtg.: A16-F-R-01-\*-K-32/3280/3290  
A22-F-R-01-\*-K-32/3280/3290

Model Numbers	"C" Thd.	"D" Thd.
A16/A22-F-R-01-*-K-32	Rc 3/8	M 10
A16/A22-F-R-01-*-K-	3/8 BSP.F	
3280	3/8 NPT	3/8-16 UNC

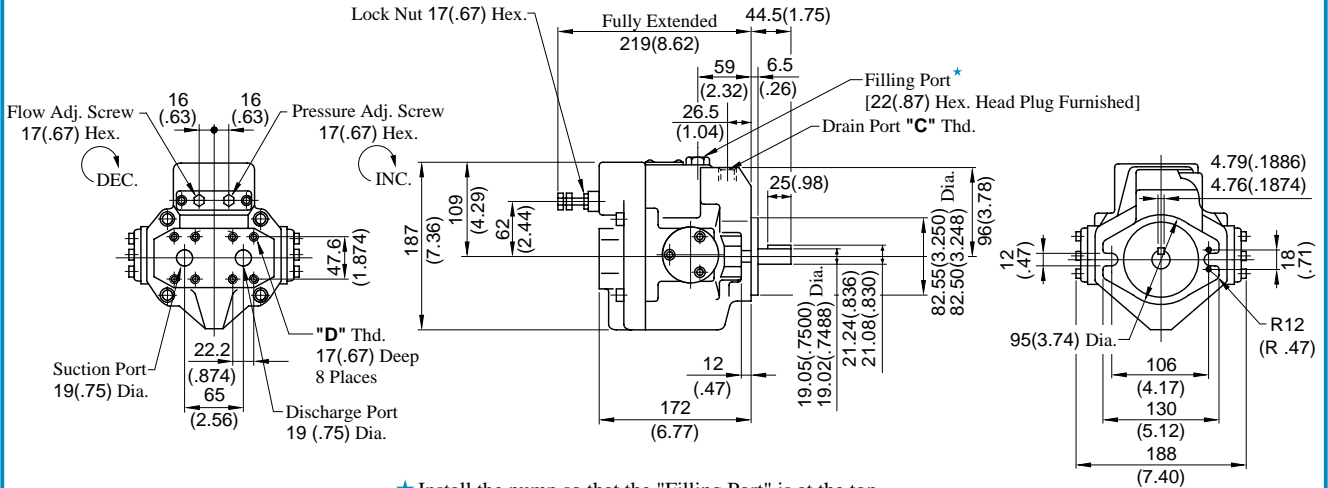

★ Install the pump so that the "Filling Port" is at the top.

Foot Mtg.: A16-L-R-01-\*-K-32/3280/3290  
A22-L-R-01-\*-K-32/3280/3290

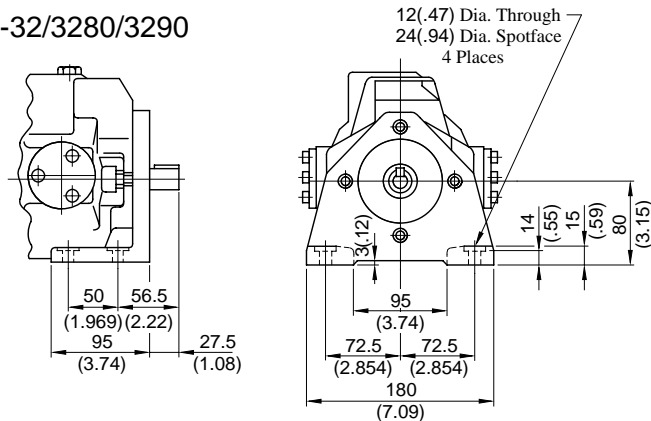

• For other dimensions, refer to "Flange Mtg.".

#### Side Port Type

DIMENSIONS IN  
MILLIMETRES (INCHES)

Flange Mtg.: A16-F-R-01-\*-S-K-32/3280/3290  
A22-F-R-01-\*-S-K-32/3280/3290

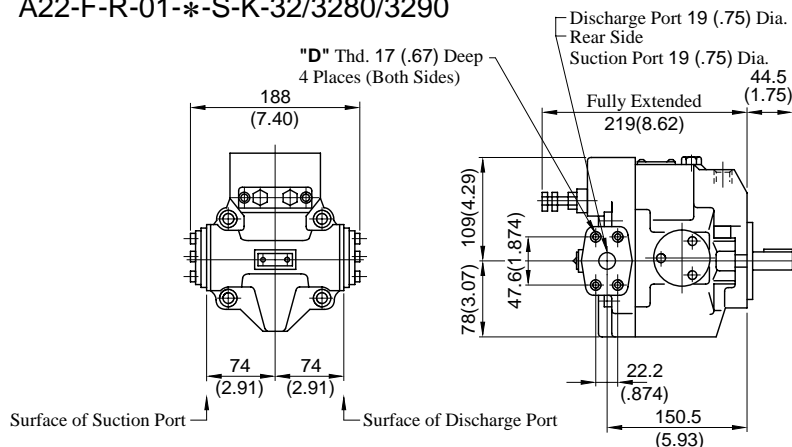

• For other dimensions, refer to "Axial Port Type".

### Installation Drawing

#### Axial Port Type

Flange Mtg.: A37-F-R-01-*\**-K-32/3280

Model Numbers	"C" Thd.
A37-F-R-01- <i>*</i> -K-32	Rc 1/2
A37-F-R-01- <i>*</i> -K-3280	1/2 BSP.F

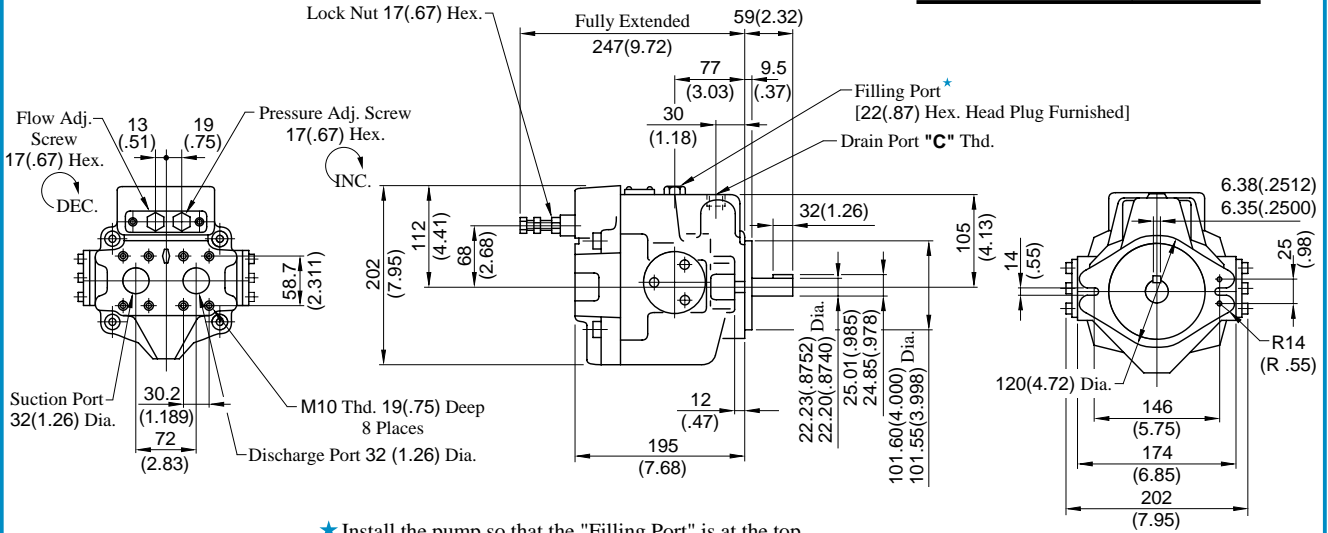

★ Install the pump so that the "Filling Port" is at the top.

Note: "Axial Port Type" is not available for N.American design Standard.

Foot Mtg.: A37-L-R-01-*\**-K-32/3280

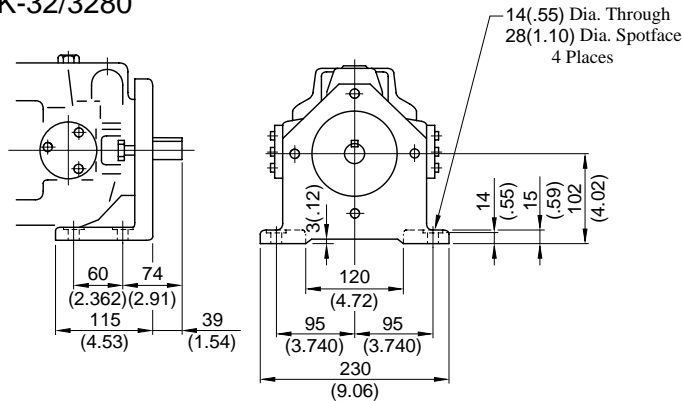

• For other dimensions, refer to "Flange Mtg.".

#### Side Port Type

DIMENSIONS IN  
MILLIMETRES (INCHES)

Flange Mtg.: A37-F-R-01-*\**-S-K-32/3280/3290

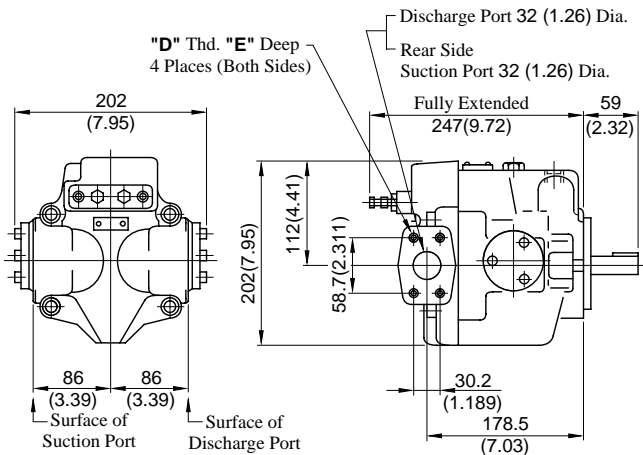

Model Numbers	"C" Thd.	"D" Thd.	E mm (IN.)
A37-F-R-01-S- <i>*</i> -K-32	Rc 1/2	M 10	19 (.75)
A37-F-R-01-S- <i>*</i> -K-3280	1/2 BSP.F		
A37-F-R-01-S- <i>*</i> -K-3290	1/2 NPT	7/16-14 UNC	20 (.79)

• For other dimensions, refer to "Axial Port Type".

• Foot Mtg. Type; Mounting bracket is common to that of "Axial Port Type".

### Installation Drawing

#### Axial Port Type

Flange Mtg.: A56-F-R-01-*\**-K-32/3280

Model Numbers	"C" Thd.
A56-F-R-01- <i>*</i> -K-32	Rc 3/4
A56-F-R-01- <i>*</i> -K-3280	3/4 BSP.F

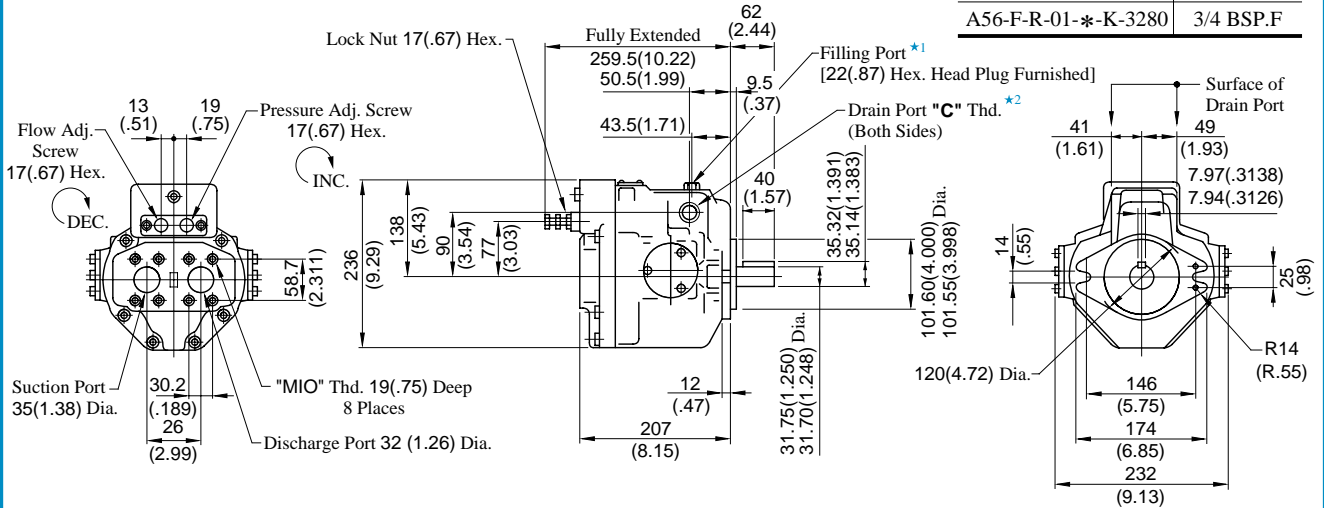

- ★ 1. Install the pump so that the "Filling Port" is at the top.
- ★ 2. Use either port of the two drain ports at your option. Keep the remaining port plugged. Note that on the European design standard (3280 Design), only the left side, as viewed from the shaft end, of the drain port is machined.

Note: "Axial Port Type" is not available for N.American design Standard.

Foot Mtg.: A56-L-R-01-*\**-K-32/3280

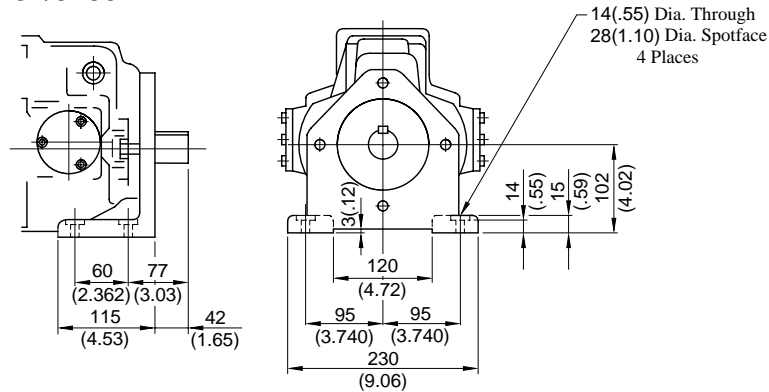

• For other dimensions, refer to "Flange Mtg.".

#### Side Port Type

DIMENSIONS IN  
MILLIMETRES (INCHES)

Flange Mtg.: A56-F-R-01-*\**-S-K-32/3280/3290

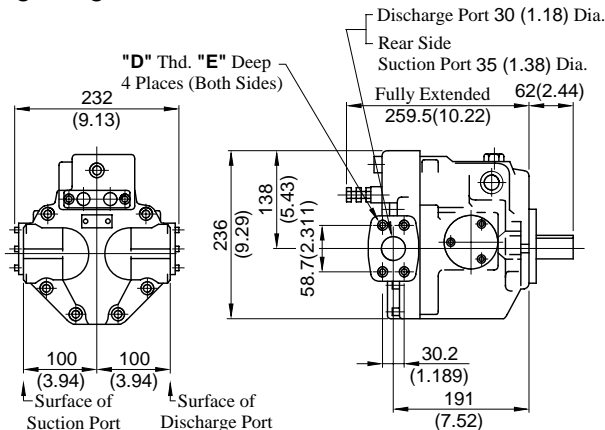

Model Numbers	"C" Thd.	"D" Thd.	E mm (IN.)
A56-F-R-01-S- <i>*</i> -K-32	Rc 3/4	M 10	19 (.75)
A56-F-R-01-S- <i>*</i> -K-3280	3/4 BSP.F		
A56-F-R-01-S- <i>*</i> -K-3290	3/4 NPT	7/16-14 UNC	20 (.79)

- For other dimensions, refer to "Axial Port Type".
- Foot Mtg. Type; Mounting bracket is common to that of "Axial Port Type".

### Installation Drawing

Flange Mtg.: A70-FR01\*S-60/6080/6090

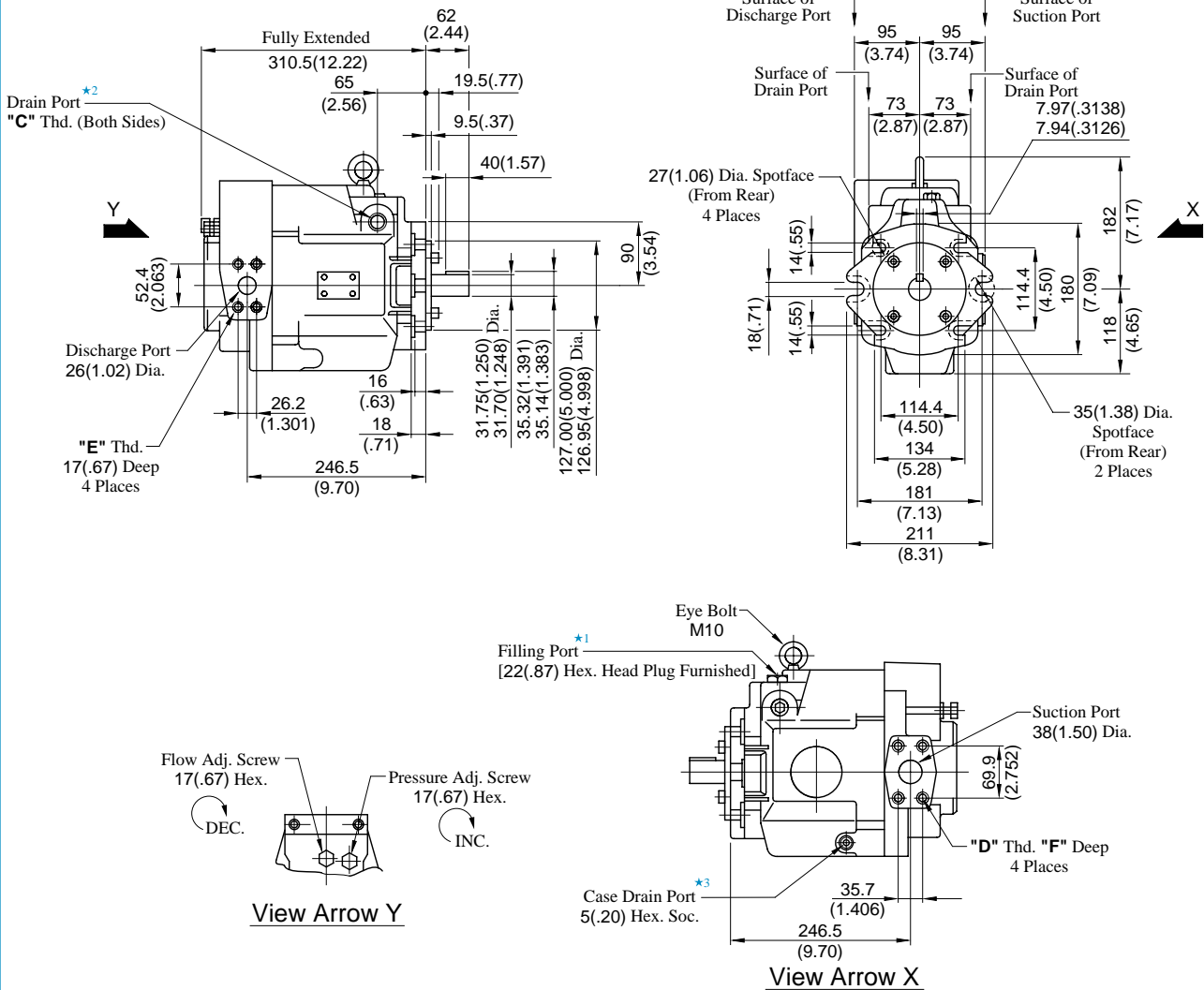

- ★ 1. Install the pump so that the "Filling Port" is at the top.
- ★ 2. Use either port of the two drain ports at your option. Keep the remaining port plugged. Note that on the European design standard (6080 design), only the left side, as viewed from the shaft end, of the drain port is machined.
- ★ 3. Case drain port is available for use when draining hydraulic fluid from pump casing.

Model Numbers	"C" Thd.	"D" Thd.	"E" Thd.	F mm (IN.)
A70-FR01*S-60	Rc 3/4	M 12	M 10	19 (.75)
A70-FR01*S-6080	3/4 BSP.F			
A70-FR01*S-6090	3/4 NPT	1/2-13 UNC	3/8-16 UNC	21 (.83)

DIMENSIONS IN  
MILLIMETRES (INCHES)

Foot Mtg.: A70-LR01\*S-60/6080/6090

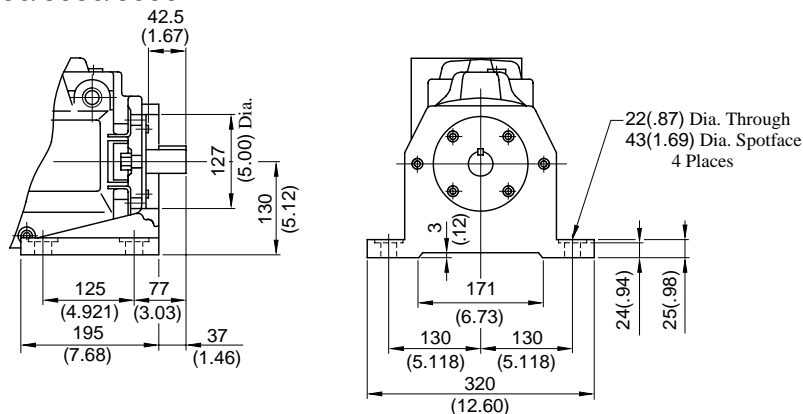

• For other dimensions, refer to "Flange Mtg.".



Flange Mtg.: A90-FR01\*S-60/6080/6090

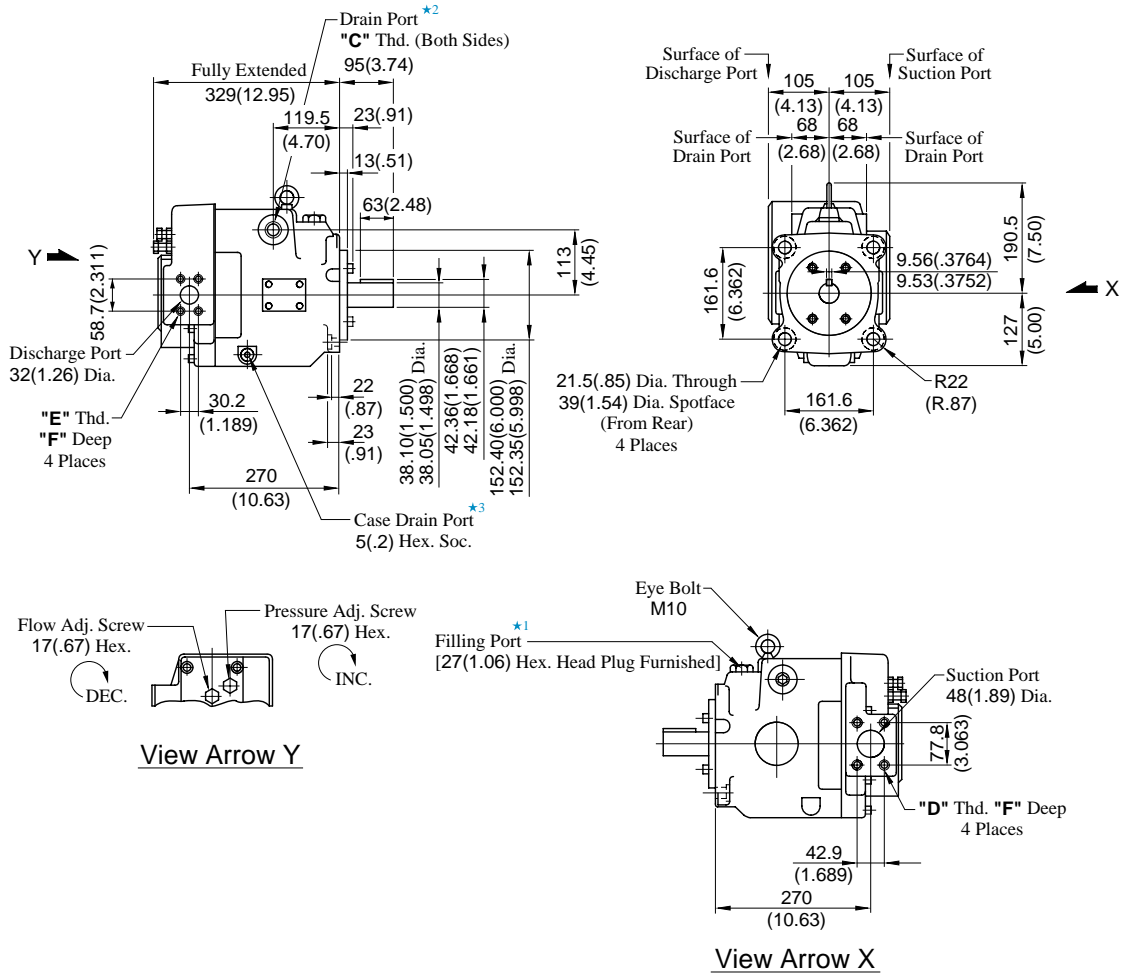

- ★ 1. Install the pump so that the "Filling Port" is at the top.
- ★ 2. Use either port of the two drain ports at your option. Keep the remaining port plugged. Note that on the European design standard (6080 design), only the left side, as viewed from the shaft end, of the drain port is machined.
- ★ 3. Case drain port is available for use when draining hydraulic fluid from pump casing.

Model Numbers	"C" Thd.	"D" Thd.	"E" Thd.	F mm (IN.)
A90-FR01*S-60	Rc 3/4	M 12	M 10	19 (.75)
A90-FR01*S-6080	3/4 BSP.F			
A90-FR01*S-6090	3/4 NPT	1/2-13 UNC	7/16-14 UNC	21 (.83)

DIMENSIONS IN  
MILLIMETRES (INCHES)

Foot Mtg.: A90-LR01\*S-60/6080/6090

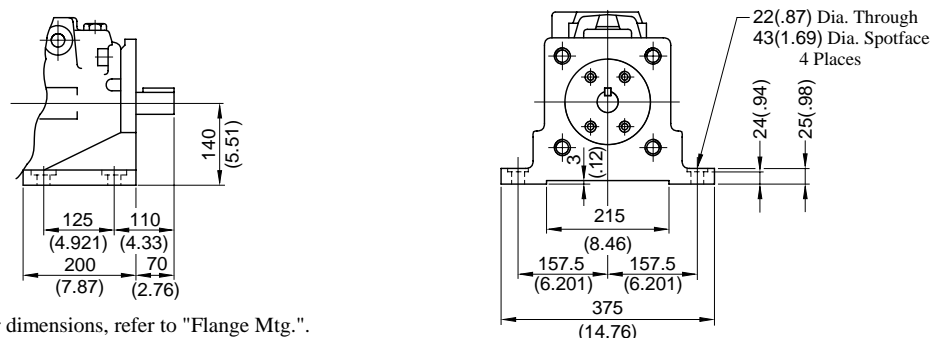

- For other dimensions, refer to "Flange Mtg."

### Installation Drawing

Flange Mtg.: A145-FR01\*S-60/6080/6090

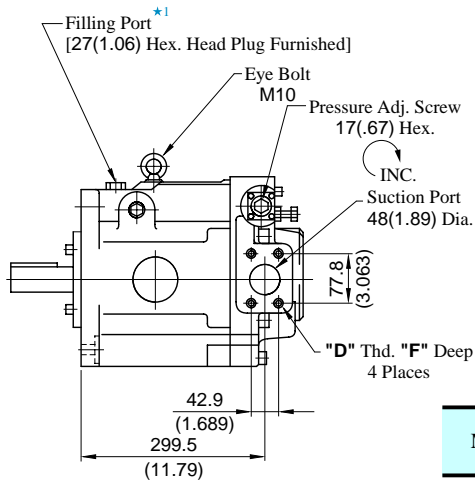
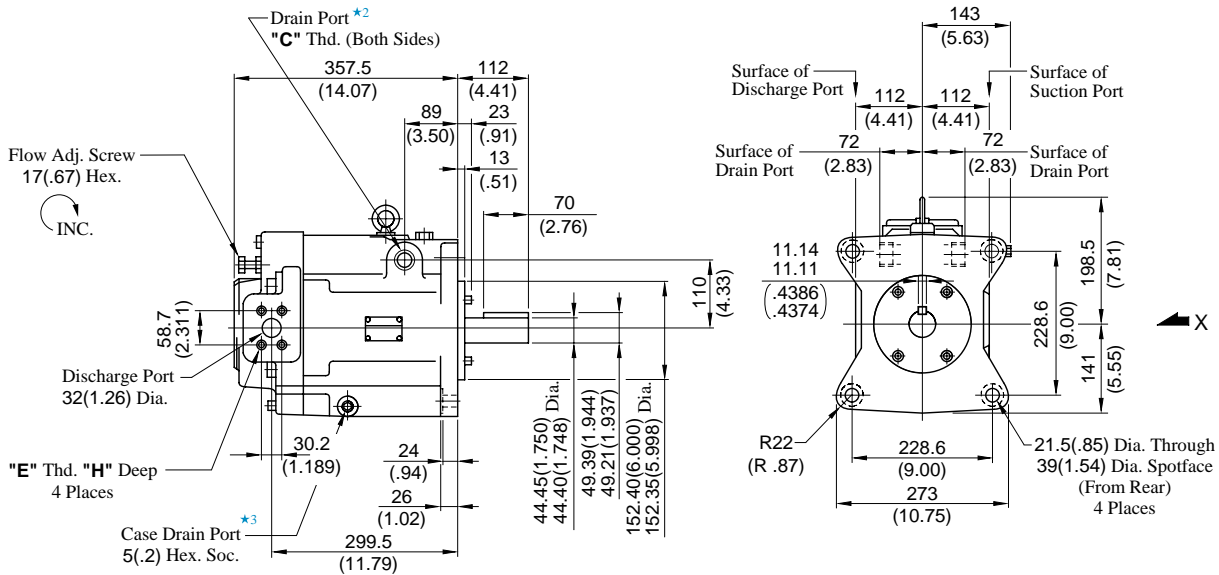

View Arrow X

- ★ 1. Install the pump so that the "Filling Port" is at the top.
- ★ 2. Use either port of the two drain ports at your option. Keep the remaining port plugged. Note that on the European design standard (6080 design), only the left side, as viewed from the shaft end, of the drain port is machined.
- ★ 3. Case drain port is available for use when draining hydraulic fluid from pump casing.

Model Numbers	"C" Thd.	"D" Thd.	"E" Thd.	Dimensions mm (IN.)	
				F	H
A145-FR01*S-60	Rc 3/4	M 12	M 10	19 (.75)	19 (.75)
A145-FR01*S-6080	3/4 BSP.F				
A145-FR01*S-6090	3/4 NPT	1/2-13 UNC	7/16-14 UNC	21 (.83)	20 (.79)

DIMENSIONS IN  
MILLIMETRES (INCHES)

Foot Mtg.: A145-LR01\*S-60/6080/6090

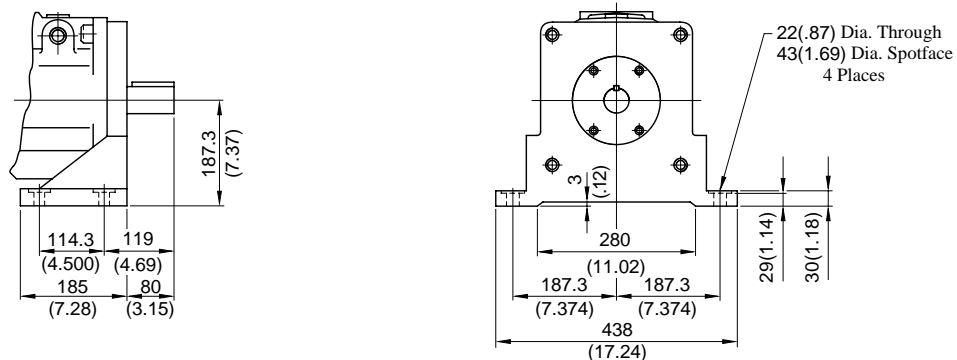

• For other dimensions, refer to "Flange Mtg".

A10-FR01\*-12/1280/1290

#### CAUTION

When making replacement of seals or bearings, please do it carefully after reading through the relevant instructions in the Operator's Manual.

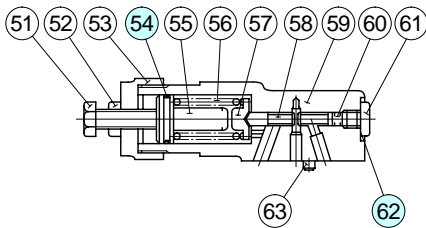
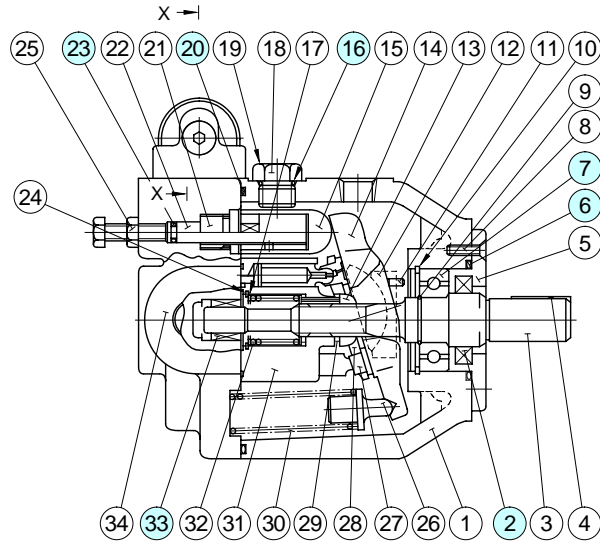
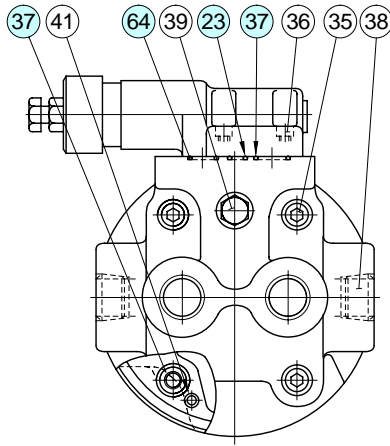

Section X-X

#### List of Seals & Bearings

Item	Name of Parts	Part Numbers	Qty.	
			Pres. Adj. Range	
			B	C & H
2*	Oil Seal	TCN24408Y	1	1
6*	O-Ring	SO-NA-G50	1	1
7	Bearing	6204	1	1
16*	O-Ring	SO-NB-P14	1	1
20*	O-Ring	SO-NB-G120	1	1
23*	O-Ring	SO-NB-P6	2	2
33	Bearing	HMK1215	1	1
37*	O-Ring	SO-NB-P12	6	5
54*	O-Ring	SO-NA-A018	1	1
62*	O-Ring	SO-NB-P10	1	1
64*	O-Ring	SO-NB-P9	—	1

★ When ordering seals, please specify the seal kit number from the table below.

#### List of Seals Kits

Pump Model Numbers	Seal Kit Numbers
A10-FR01B-12/1280/1290	KS-A10-01B-12
A10-FR01C-12/1280/1290	KS-A10-01H-12
A10-FR01H-12/1280/1290	

### Spare Parts List

A16/A22/A37/A56-\*-R-01-\*-K-32/3280/3290

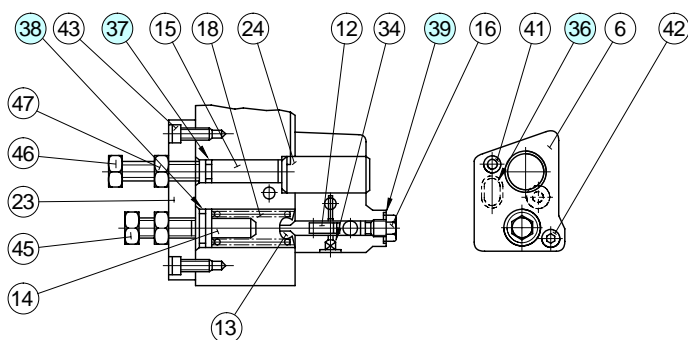
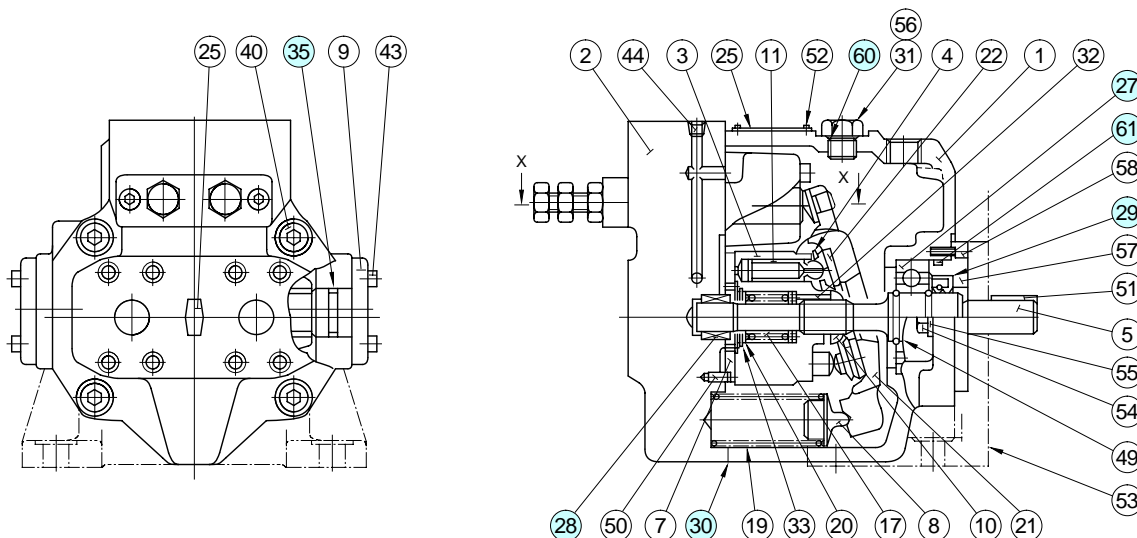

Section X-X

### CAUTION

When making replacement of seals or bearings, please do it carefully after reading through the relevant instructions in the Operator's Manual.

#### List of Seal and Bearings

Item	Name of Parts	Part Numbers				Qty.
		A16-*-R-01	A22-*-R-01	A37-*-R-01	A56-*-R-01	
27	Bearing	6305		6307	NUP 207E	1
28	Bearing	HMK 1715	Z30-1303-PK410300-8	HMK 2025V2	HMK 2530V2	1
29*	Oil Seal	TCN 254511		TCN 355511	TCN 355511	1
30*	Gasket	1303-PK211969-1		1316-PK211970-9	1307-PK211971-7	1
35*	O-Ring	SO-NA-G25		SO-NB-G30	SO-NA-P36	2
36*	O-Ring	SO-NB-P12		SO-NB-P10A		1
37*	O-Ring	SO-NB-P9				1
38*	O-Ring	SO-NA-A017				1
39*	Seal Washer	W8				1
60*	O-Ring	SO-NB-P14				1
61*	O-Ring	SO-NA-G55		SO-NA-G75		1

★ When ordering seals, please specify the seal kit number from the table below.

#### List of Seal Kits

Pump Model Numbers	Seal Kit Numbers
A16-*-R-01-*-K-*-32*	KS-A16-01-32
A22-*-R-01-*-K-*-32*	
A37-*-R-01-*-K-*-32*	KS-A37-01-32
A56-*-R-01-*-K-*-32*	KS-A56-01-32

A70/A90-\*R01\*S-60/6080/6090

### CAUTION

When making replacement of seals or bearings, please do it carefully after reading through the relevant instructions in the Operator's Manual.

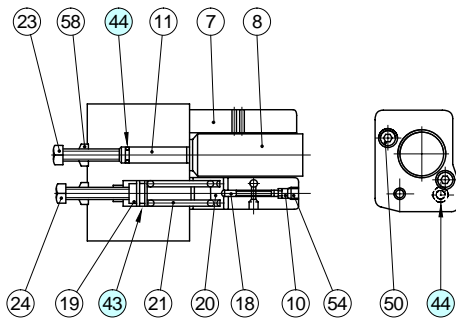
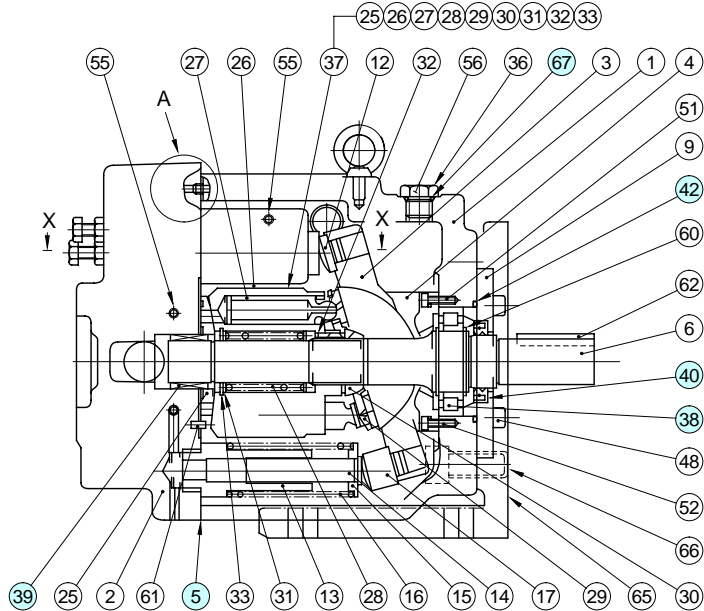
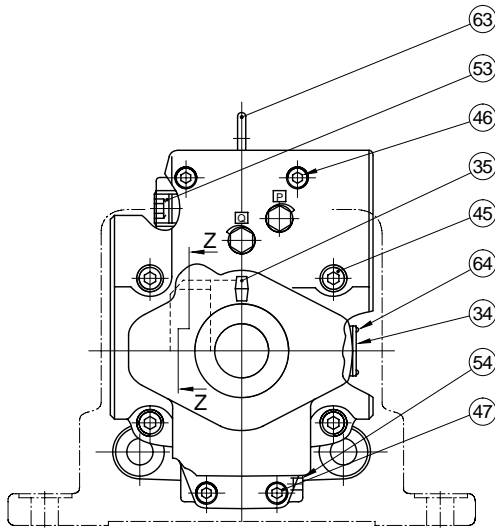

Section X-X

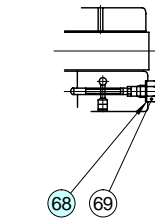

Section X-X  
(Only for "A70")

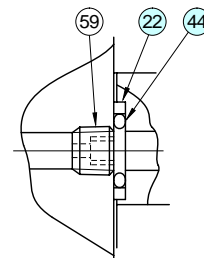

Detail "A"

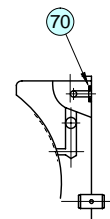

Section Z-Z

#### ● List of Seals and Bearings

Item	Name of Parts	Part Numbers		Qty.
		A70-*R01*S	A90-*R01*S	
5*	Gasket	1314E-PK211972-5	1310E-PK211973-3	1
22	Back Up Ring	1310E-PK412440-0	1310E-PK412440-0	1
38	Bearing	NUP 208EX50	NUP 210E	1
39	Needle Bearing	HMK 3030V2	HMK 3530BV2	1
40*	Oil Seal	TCN 355511	TCN 456812	1
42*	O-Ring	SO-FA-G85	SO-FA-G95	1
43*	O-Ring	SO-NA-P18	SO-NA-P18	1
44*	O-Ring	SO-NB-P9	SO-NB-P9	3
67*	O-Ring	SO-NB-P14	SO-NB-P18	1
68*	Seal Washer	W10	—	1
70*	O-Ring	—	SO-NB-P5	1

#### ● List of Seal Kits

Pump Model Numbers	Seal Kit Numbers
A70-*R01*S-60*	KS-A70-01-60
A90-*R01*S-60*	KS-A90-01-60

★ When ordering the seals, please specify the seal kit number from the table left.

### Spare Parts List

A145-\*R01\*S-60/6080/6090

#### CAUTION

When making replacement of seals or bearings, please do it carefully after reading through the relevant instructions in the Operator's Manual.

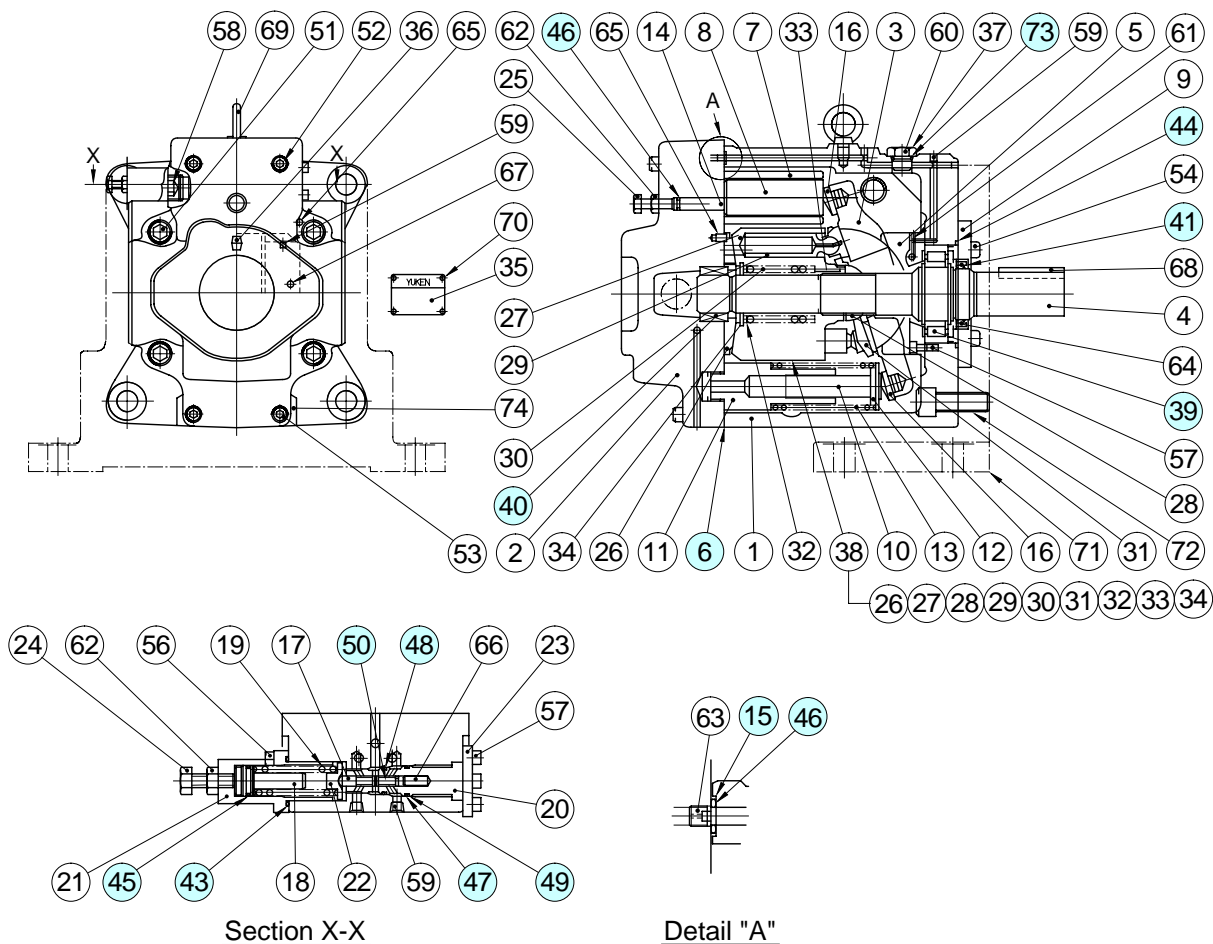

#### List of Seals and Bearings

Item	Name of Parts	Part Numbers	Qty.
6*	Gasket	1312-PK211974-1	1
15	Back Up Ring	1310E-PK412440-0	1
39	Bearing	NUP 2211ET2	1
40	Needle Bearing	8Q-NK38×55×30	1
41*	Oil Seal	TCN 507212	1
43*	O-Ring	S-31.5 (NBR, Hs70)	1
44*	O-Ring	SO-FA-G105	1
45*	O-Ring	SO-NA-P18	1
46*	O-Ring	SO-NB-P9	2
47*	O-Ring	SO-NB-A017	1
48*	O-Ring	SO-NB-A016	1
49	Back Up Ring	For SO-NB-A017	1
50	Back Up Ring	For SO-NB-A016	1
73*	O-Ring	SO-NB-P18	1

★ When ordering seals, please specify the kit number "KS-A145-01-60".

### Specifications

Graphic Symbol

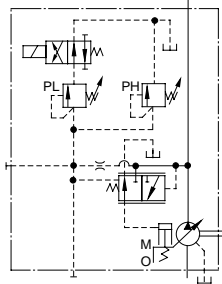

Performance Characteristics

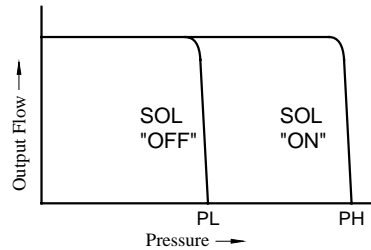

### Specifications

Model Numbers	Geometric Displacement cm <sup>3</sup> /rev (cu. in. /rev)	Minimum Adj. Flow cm <sup>3</sup> /rev (cu. in. /rev)	Operating Pres. MPa (PSI)		Minimum Adj. Pres. MPa (PSI)	Shaft Speed Range r/min		Approx. Mass kg (lbs.)	
			Rated <sup>*2</sup>	Intermittent <sup>*1</sup>		Max.	Min.	Flange Mtg.	Foot Mtg.
A16-*R-02-*K-32*	15.8 (964)	4 (.244)	16 (2320)	21 (3050)	1.2 (170)	1800	600	24.5 (54.0)	26.7 (58.9)
A22-*R-02-*K-32*	22.2 (1.355)	6 (.366)	16 (2320)	16 (2320)	1.2 (170)	1800	600	24.5 (54.0)	26.7 (58.9)
A37-*R-02-*K-32*	36.9 (2.25)	10 (.61)	16 (2320)	21 (3050)	1.2 (170)	1800	600	36 (79.4)	40.3 (88.9)
A56-*R-02-*K-32*	56.2 (3.43)	12 (.73)	16 (2320)	21 (3050)	1.2 (170)	1800	600	43 (94.8)	47.3 (104)
A70-*R02S*-60*	70.0 (4.27)	30 (1.83)	25 (3630)	25 (3630)	2 (290)	1800	600	63.5 (140)	75.5 (166)
A90-*R02S*-60*	91.0 (5.55)	56 (3.42)	25 (3630)	25 (3630)	2 (290)	1800	600	80.5 (178)	101 (223)
A145-*R02S*-60*	145 (8.85)	83 (5.06)	25 (3630)	25 (3630)	2 (290)	1800	600	97.5 (215)	122.5 (270)

- ★1. Whenever setting pressure, make sure the full cut-off pressure never exceeds the maximum intermittent pressure.
- ★2. When operating the pump exceeding the rated pressure, operating conditions are restricted. Refer to page 6 for the details.

### Solenoid Ratings

Electric Source	Coil Type	Frequency (Hz)	Voltage (V)		Current & Power at Rated Voltage		
			Source Rating	Serviceable Range	Inrush* (A)	Holding (A)	Power (W)
AC	A100	50	100	80 - 110	2.42	0.51	—
			100	90 - 120	2.14	0.37	
			110		2.35	0.44	
	A120	50	120	96 - 132	2.02	0.42	
			108 - 144	1.78	0.31		
	A200	50	200	160 - 220	1.21	0.25	
			200	180 - 240	1.07	0.19	
			220		1.18	0.22	
	A240	50	240	192 - 264	1.01	0.21	
			216 - 288	0.89	0.15		
DC (K Series)	D12	—	12	10.8 - 13.2	—	2.45	29
			24	21.6 - 26.4		1.23	
			48	43.2 - 52.8		0.61	
AC→DC Rectified	R100	50/60	100	90 - 110	—	0.33	29
			200	180 - 220		0.16	

★ Inrush current in the above table shows rms values at maximum stroke.

### Model Number Designation

#### ■ Model Number Designation

A16	-F	-R	-02	-S	-K	-A100	-32	*
Series Number	Mounting	Direction of Rotation	Control Type	Port Position	Shaft Extension	Coil Type of Solenoid Valve	Design Number	Design Std.
<b>A16</b> (15.8 cm <sup>3</sup> /rev)	<b>F:</b> Flange Mtg.	(Viewed from) (Shaft End)	<b>02:</b> Solenoid Two Pressure Control Type	<b>None:</b> Axial Port <sup>*2</sup>	<b>K:</b> Keyed Shaft	<b>AC</b> A100,A120 A200,A240  <b>DC</b> D12,D24 D48 (AC→DC Rectified) R100,R200	<b>32</b>	Refer to <sup>*3</sup>
<b>A22</b> (22.2 cm <sup>3</sup> /rev)							<b>32</b>	
<b>A37</b> (36.9 cm <sup>3</sup> /rev)							<b>32</b>	
<b>A56</b> (56.2 cm <sup>3</sup> /rev)							<b>32</b>	
	<b>L:</b> Foot Mtg.	<b>R:</b> Clockwise <sup>*1</sup> (Normal)		<b>S:</b> Side Port				

A70	-F	R	02	S	A100	-60	*
Series Number	Mounting	Direction of Rotation	Control Type	Port Position	Coil Type of Solenoid Valve	Design Number	Design Std.
<b>A70</b> (70 cm <sup>3</sup> /rev)	<b>F:</b> Flange Mtg.	(Viewed from) (Shaft End)	<b>02:</b> Solenoid Two Pressure Control Type	<b>S:</b> Side Port	<b>AC</b> A100,A120 A200,A240  <b>DC</b> D12,D24 D48 (AC→DC Rectified) R100,R200	<b>60</b>	Refer to <sup>*3</sup>
<b>A90</b> (91.0 cm <sup>3</sup> /rev)						<b>60</b>	
<b>A145</b> (145 cm <sup>3</sup> /rev)						<b>60</b>	
	<b>L:</b> Foot Mtg.	<b>R:</b> Clockwise <sup>*1</sup> (Normal)					

- ★1. Available to supply pump with anti-clockwise rotation. Consult Yuken for details.
- ★2. The axial port is not available to the N. American Design Standard of A37 and A56 series.
- ★3. Design Standards: None ..... Japanese Standard "JIS"  
80 ..... European Design Standard  
90 ..... N. American Design Standard

#### ■ Performance Characteristics

For performance characteristics, refer to models of pressure compensator type on page 10 to 16.

#### ■ Pipe Flange Kit

For pipe flange, refer to form of pressure compensator type on page 7.



#### Axial Port Type

Flange Mtg.: A16-F-R-02-K-\*-32/3290  
A22-F-R-02-K-\*-32/3290

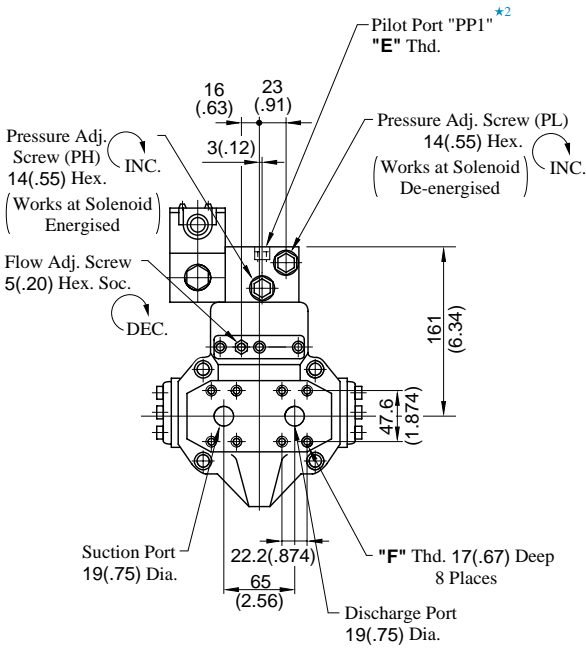
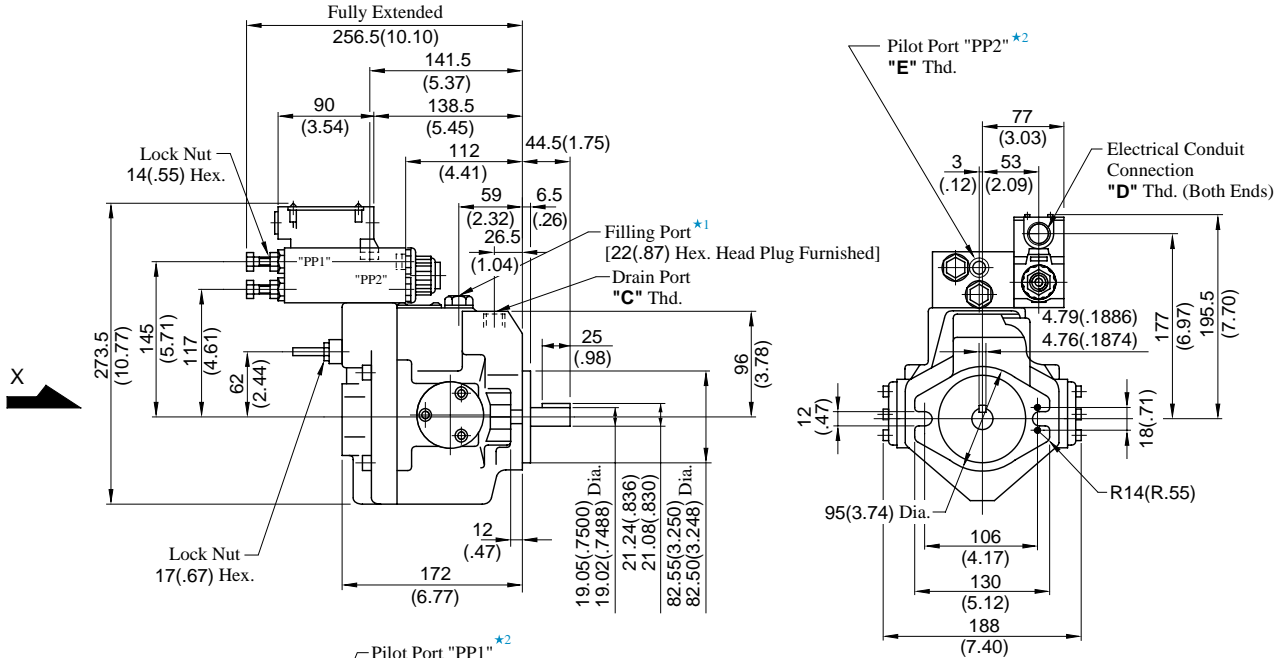

A16-F-R-02-K-\*-3280  
A22-F-R-02-K-\*-3280

Cable Departure  
Cable Applicable:  
Outside Dia. .... 8-10mm(.31-.39 in.)  
Conductor Area ..... Not Exceeding 1.5mm<sup>2</sup>(.002 Sq. IN.)

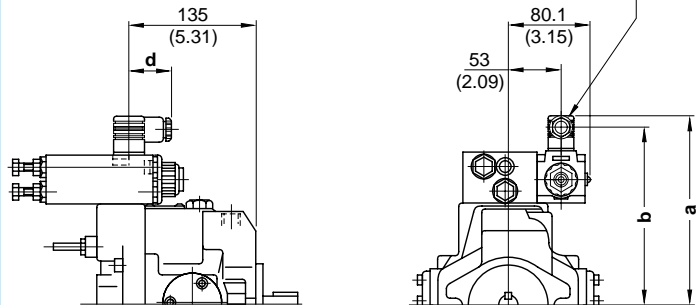

Model Numbers	mm (IN.)		
	a	b	d
A16/A22-F-R-02-K-A*- 3280	194 (7.64)	182. (7.17)	39 (1.54)
A16/A22-F-R-02-K-D*-	205 (8.07)	193 (7.60)	39 (1.54)
A16/A22-F-R-02-K-D*-	208 (8.19)	186.2 (7.33)	53 (2.09)

• For other dimensions, refer to 32/3290 design.

- ★ 1. Install the pump so that the "Filling Port" is at the top.
- ★ 2. The pilot port provided is for connecting a control valve, if multistage pressure control is required.

Model Numbers	"C" Thd.	"D" Thd.	"E" Thd.	"F" Thd.
A16/A22-F-R-02-K-*-32	Rc 3/8	G 1/2	Rc 1/4	M10
A16/A22-F-R-02-K-*-3280	3/8 BSP.F	—	1/4 BSP. Tr	
A16/A22-F-R-02-K-*-3290	3/8 NPT	1/2 NPT	1/4 NPT	3/8-16 UNC

DIMENSIONS IN MILLIMETRES (INCHES)

#### • Side Port Type

Port mounting dimensions are the same as those of pressure compensator model. Refer to page 18 for port mounting dimensions.

#### • Foot Mounting Type

Mounting bracket is common to that of pressure compensator model. Refer to page 18 for the dimensions of mounting bracket.

### Installation Drawing

#### Side Port Type

Flange Mtg. : A37-F-R-02-S-K\*-32/3290

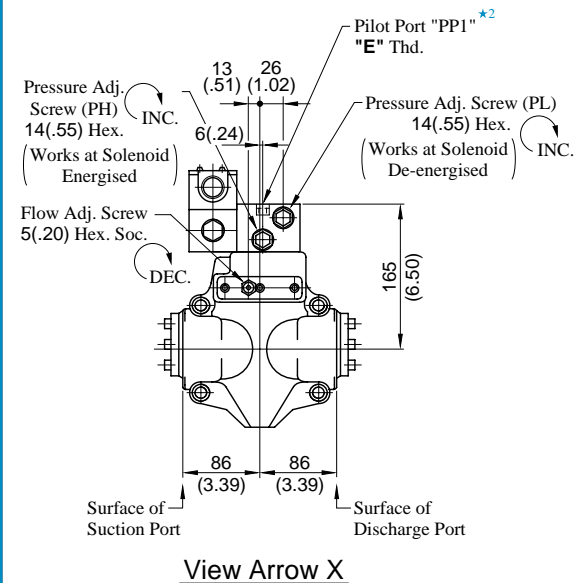
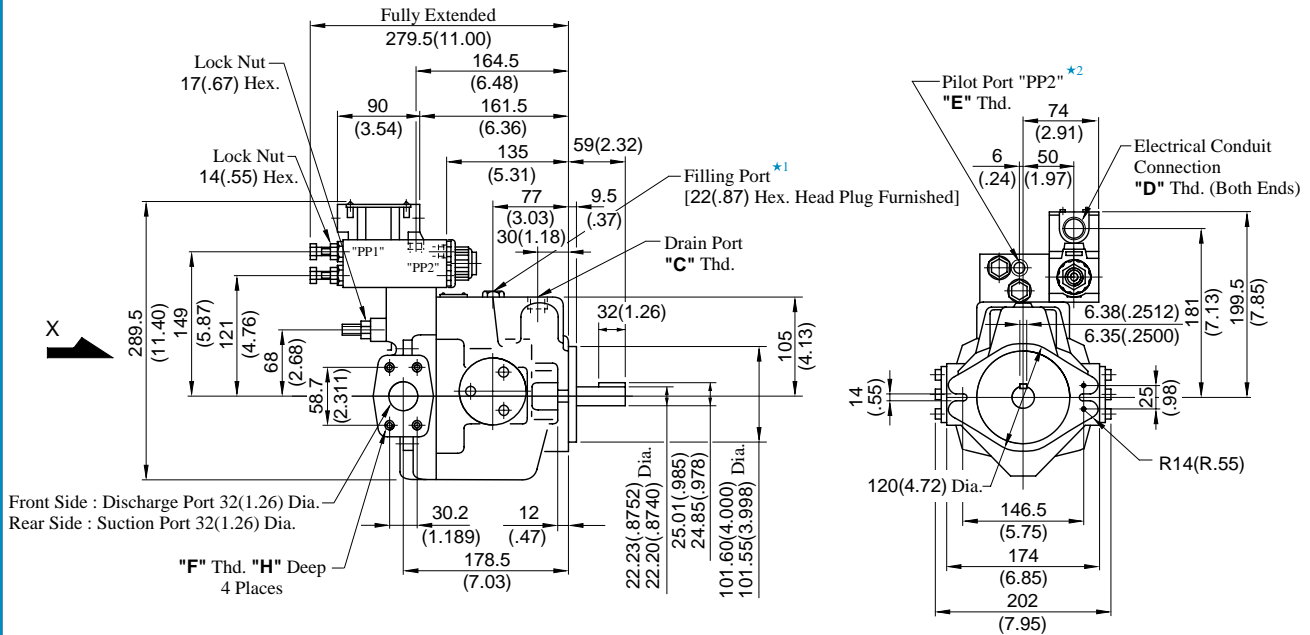

- ★ 1. Install the pump so that the "Filling Port" is at the top.
- ★ 2. The pilot port provided is for connecting a control valve, if multistage pressure control is required.

#### A37-F-R-02-S-K\*-3280

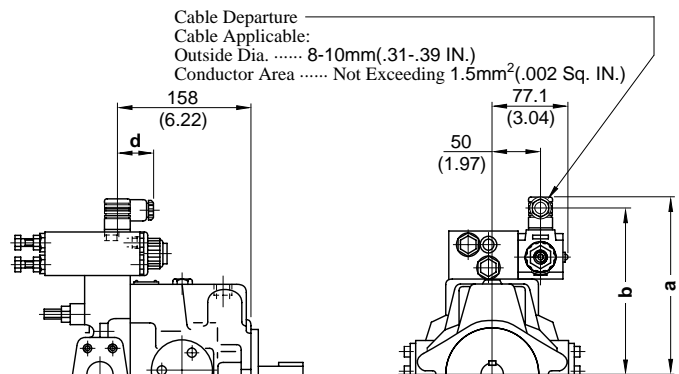

Model Numbers	mm (IN.)		
	a	b	d
A37-F-R-02-S-K-A*-3280	198 (7.80)	186 (7.32)	39 (1.54)
A37-F-R-02-S-K-D*-3280	209 (8.23)	197 (7.76)	39 (1.54)
A37-F-R-02-S-K-R*-3280	212 (8.35)	190.2 (7.49)	53 (2.09)

• For other dimensions, refer to 32/3290 design.

Model Numbers	"C" Thd.	"D" Thd.	"E" Thd.	"F" Thd.	"H" mm (IN.)
A37-F-R-02-S-K-*-32	Rc 1/2	G 1/2	Rc 1/4	M10	19 (.75)
A37-F-R-02-S-K-*-3280	1/2 BSP.F	—	1/4 BSP. Tr		
A37-F-R-02-S-K-*-3290	1/2 NPT	1/2 NPT	1/4 NPT	7/16-14 UNC	20 (.79)

### DIMENSIONS IN MILLIMETRES (INCHES)

#### • Axial Port Type

Port mounting dimensions are the same as those of pressure compensator model. Refer to page 19 for port mounting dimensions.

#### • Foot Mounting Type

Mounting bracket is common to that of pressure compensator model. Refer to page 19 for the dimensions of mounting bracket.

#### Side Port Type

Flange Mtg.: A56-F-R-02-S-K-\*-32/3290

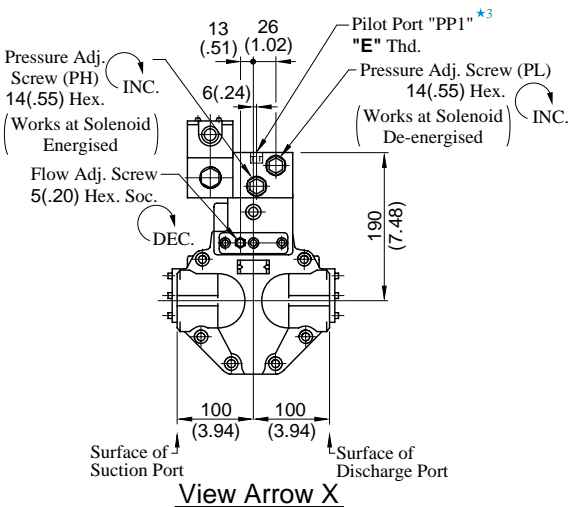
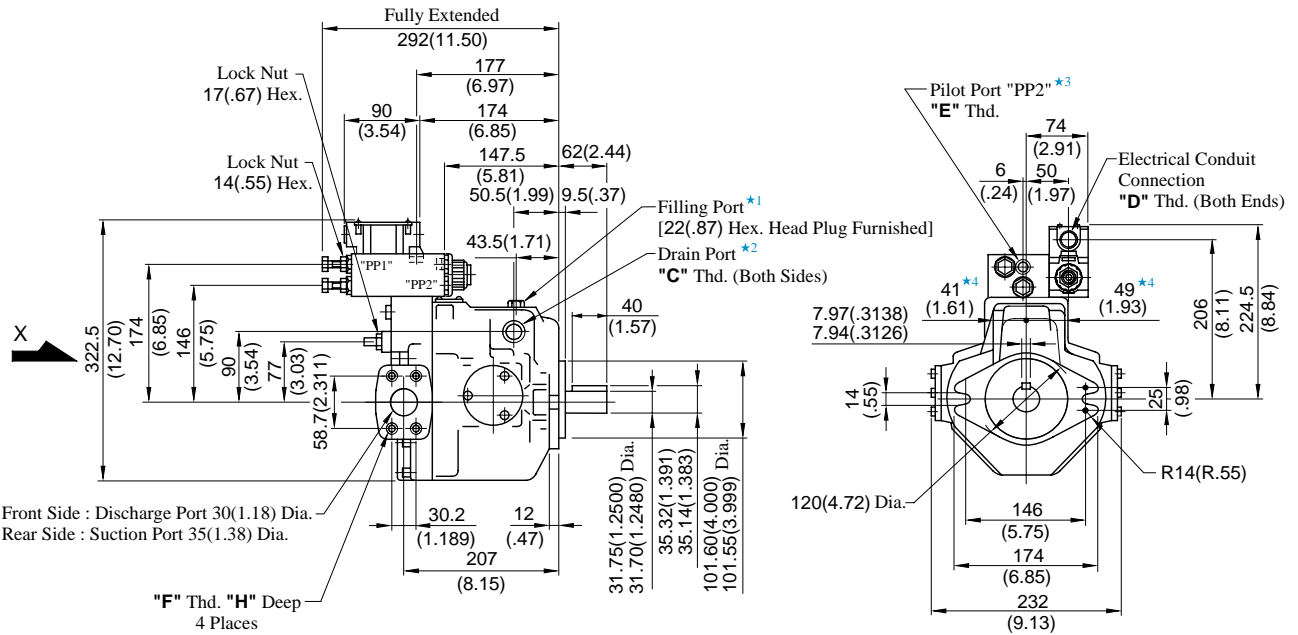

#### A56-F-R-02-S-K-\*-3280

Cable Departure  
Cable Applicable:  
Outside Dia. .... 8-10mm(.31-.39 IN.)  
Conductor Area ..... Not Exceeding 1.5mm<sup>2</sup>(.002 Sq. IN.)

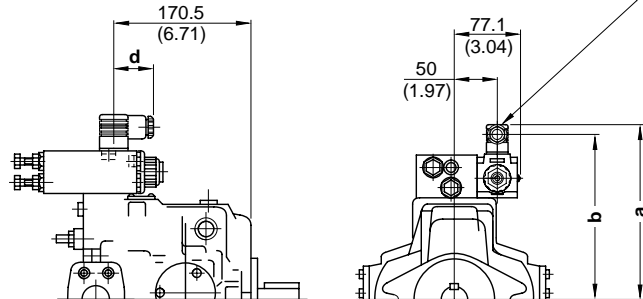

Model Numbers	mm (IN.)		
	a	b	d
A56-F-R-02-S-K-A*-3280	223 (8.78)	211 (8.31)	39 (1.54)
A56-F-R-02-S-K-D*-3280	234 (9.21)	222 (8.74)	39 (1.54)
A56-F-R-02-S-K-R*-3280	237 (9.33)	215.2 (8.47)	53 (2.09)

• For other dimensions, refer to 32/3290 design.

- ★ 1. Install the pump so that the "Filling Port" is at the top.
- ★ 2. Use either port of two drain ports at your option. Keep the remaining port plugged. Note that on the European Design Standard (3280 Design), only the left side, as viewed from the shaft end, of the drain port is machined.
- ★ 3. The pilot port provided is for connecting a control valve, if multistage pressure control is required.
- ★ 4. Dimensions show surface of drain port.

Model Numbers	"C" Thd.	"D" Thd.	"E" Thd.	"F" Thd.	"H" mm (IN.)
A56-F-R-02-S-K-*-32	Rc 3/4	G 1/2	Rc 1/4	M10	19 (.75)
A56-F-R-02-S-K-*-3280	3/4 BSP.F	—	1/4 BSP. Tr		
A56-F-R-02-S-K-*-3290	3/4 NPT	1/2 NPT	1/4 NPT	7/16-14 UNC	20 (.79)

#### DIMENSIONS IN MILLIMETRES (INCHES)

#### • Axial Port Type

Port mounting dimensions are the same as those of pressure compensator model. Refer to page 20 for port mounting dimensions.

#### • Foot Mounting Type

Mounting bracket is common to that of pressure compensator model. Refer to page 20 for the dimensions of mounting bracket.

### Installation Drawing

Flange Mtg. : A70-FR02S\*-60/6090

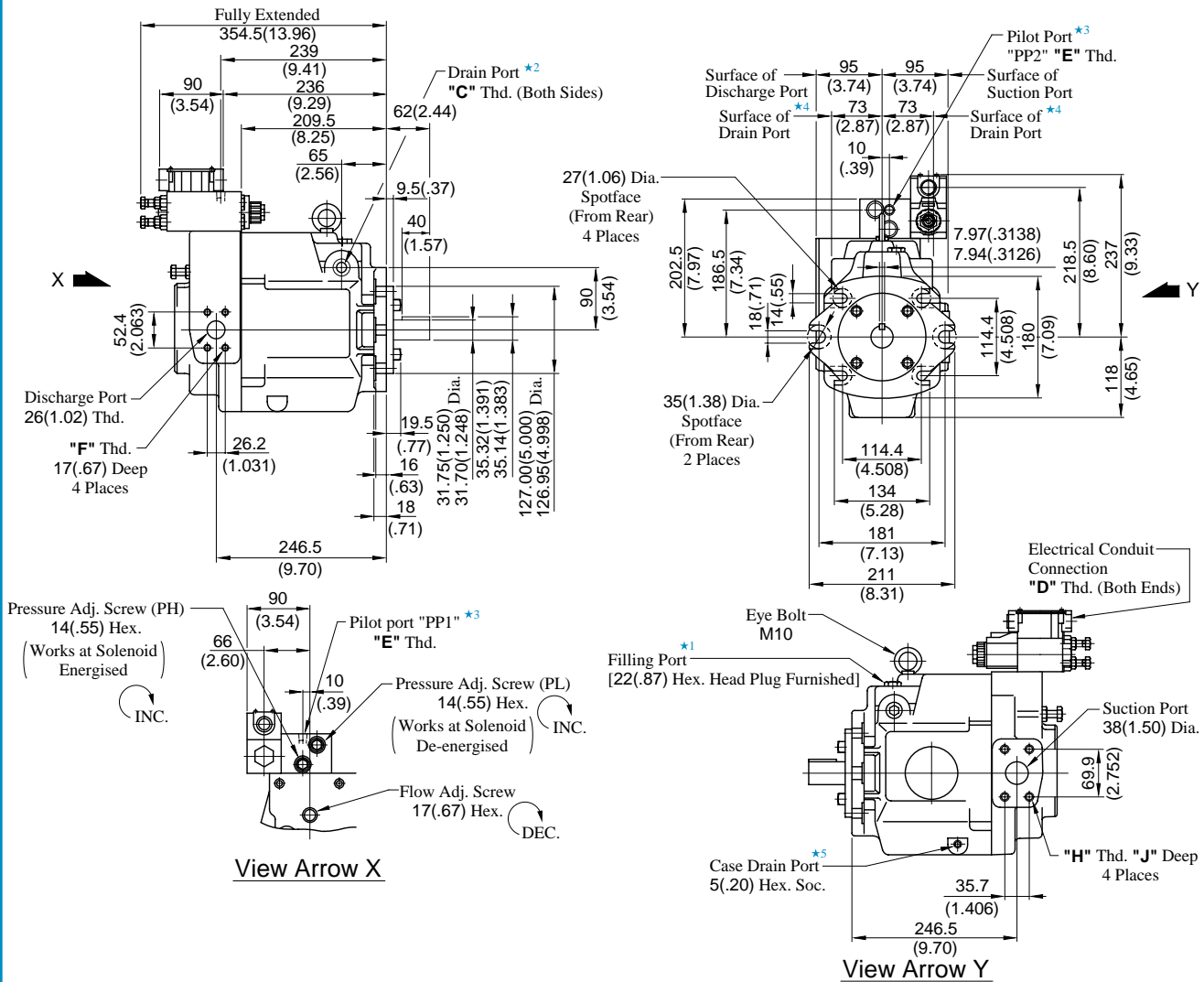

Model Numbers	"C" Thd.	"D" Thd.	"E" Thd.	"F" Thd.	"H" Thd.	"J" mm (IN.)
A70-FR02S*-60	Rc 3/4	G 1/2	Rc 1/4	M10	M12	19 (.75)
A70-FR02S*-6080	3/4 BSP.F	—	1/4 BSP. Tr			
A70-FR02S*-6090	3/4 NPT	1/2 NPT	1/4 NPT	7/16-14 UNC	1/2-13 UNC	21 (.83)

### A70-FR02S\*-6080

Cable Departure  
Cable Applicable:  
Outside Dia. .... 8-10mm (.31-.39 IN.)  
Conductor Area ..... Not Exceeding 1.5mm<sup>2</sup> (.002 Sq. IN.)

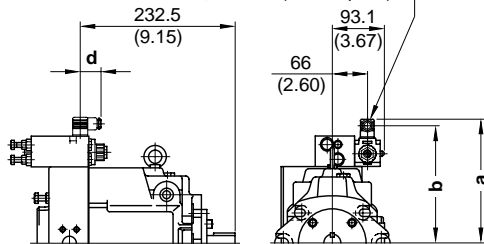

Model Numbers	mm (IN.)		
	a	b	d
A70-FR02SA*-6080	236 (9.29)	224 (8.82)	39 (1.54)
A70-FR02SD*-6080	247 (9.72)	235 (9.25)	39 (1.54)
A70-FR02SR*-6080	250 (9.84)	228.2 (8.98)	53 (2.09)

• For other dimensions, refer to 60/6090 design.

- ★ 1. Install the pump so that the "Filling Port" is at the top.
- ★ 2. Use either port of two drain ports at your option. Keep the remaining port plugged. Note that on the European Design Standard (6080 Design), only the left side, as viewed from the shaft end, of the drain port is machined.
- ★ 3. The pilot port provided is for connecting a control valve, if multistage pressure control is required.
- ★ 4. Dimensions show surface of drain port.
- ★ 5. Case drain port is available for use when draining hydraulic fluid from pump casing.

DIMENSIONS IN  
MILLIMETRES (INCHES)

### ● Foot Mounting Type

Mounting bracket is common to that of pressure compensator model. Refer to page 21 for the dimensions of mounting bracket.

#### Flange Mtg.: A90-FR02S\*-60/6090

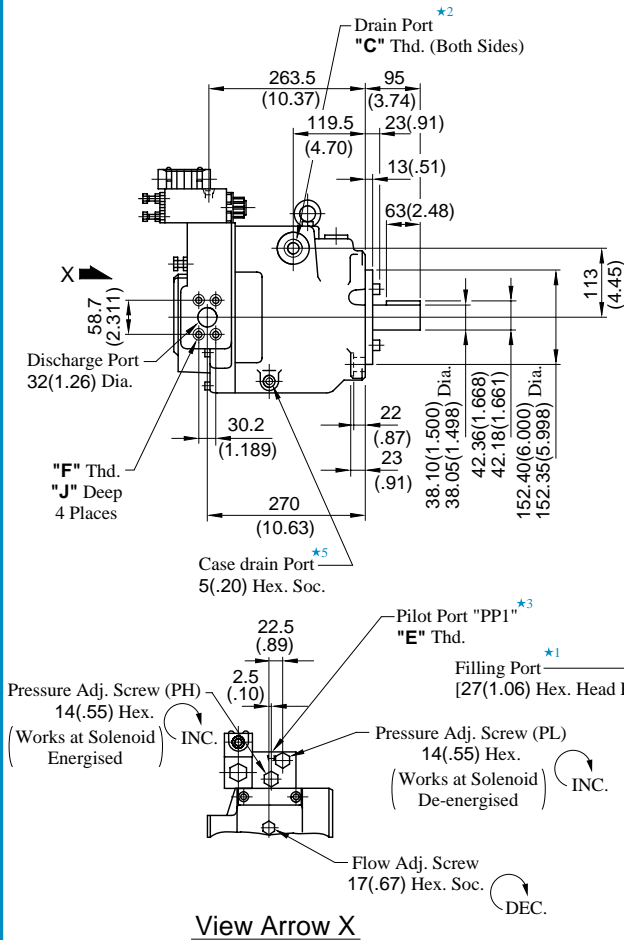

View Arrow X

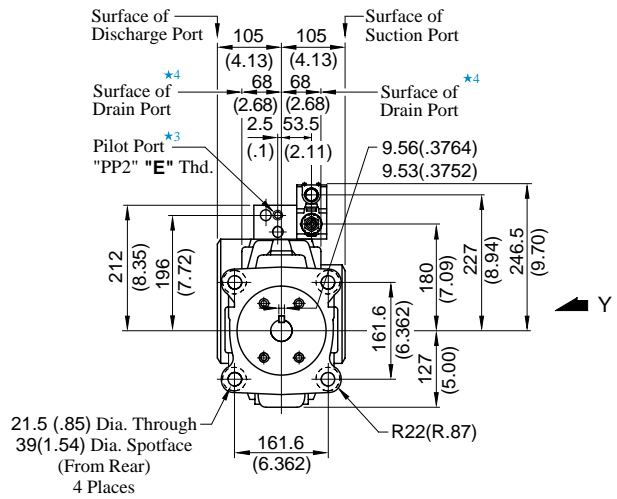

View Arrow Y

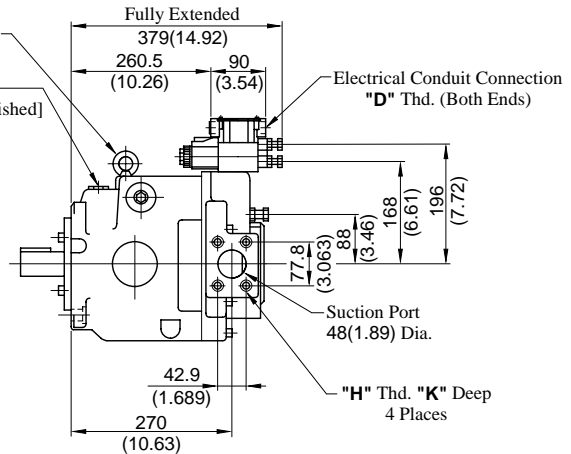

Model Numbers	"C" Thd.	"D" Thd.	"E" Thd.	"F" Thd.	"H" Thd.	"J" mm (IN.)	"K" mm (IN.)
A90-FR02S*-60	Rc 3/4	G 1/2	Rc 1/4	M10	M12	19 (.75)	19 (.75)
A90-FR02S*-6080	3/4 BSP.F	—	1/4 BSP. Tr				
A90-FR02S*-6090	3/4 NPT	1/2 NPT	1/4 NPT	7/16-14 UNC	1/2-13 UNC	20 (.79)	21 (.83)

#### A90-FR02S\*-6080

Cable Departure  
Cable Applicable:  
Outside Dia. .... 8-10mm (.31-.39 IN.)  
Conductor Area ..... Not Exceeding 1.5mm<sup>2</sup> (.002 Sq. IN.)

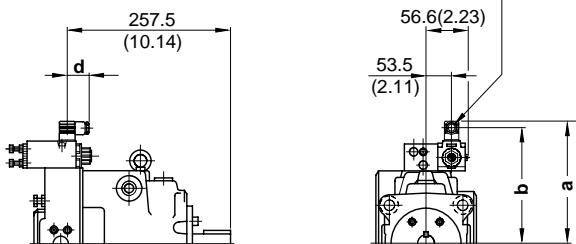

Model Numbers	mm (IN.)		
	a	b	d
A90-02FRSA*-6080	245 (9.65)	233 (9.17)	39 (1.54)
A90-02FRSD*-6080	256 (10.08)	244 (9.61)	39 (1.54)
A90-02FRSR*-6080	259 (10.20)	237.2 (9.34)	53 (2.09)

• For other dimensions, refer to 60/6090 design.

- ★ 1. Install the pump so that the "Filling Port" is at the top.
- ★ 2. Use either port of two drain ports at your option. Keep the remaining port plugged. Note that on the European Design Standard (6080 Design), only the left side, as viewed from the shaft end, of the drain port is machined.
- ★ 3. The pilot port provided is for connecting a control valve, if multistage pressure control is required.
- ★ 4. Dimensions show surface of drain port.
- ★ 5. Case drain port is available for use when draining hydraulic fluid from pump casing.

DIMENSIONS IN  
MILLIMETRES (INCHES)

#### ● Foot Mounting Type

Mounting bracket is common to that of pressure compensator model. Refer to page 22 for the dimensions of mounting bracket.

### Installation Drawing

Flange Mtg. : A145-FR02S\*-60/6090

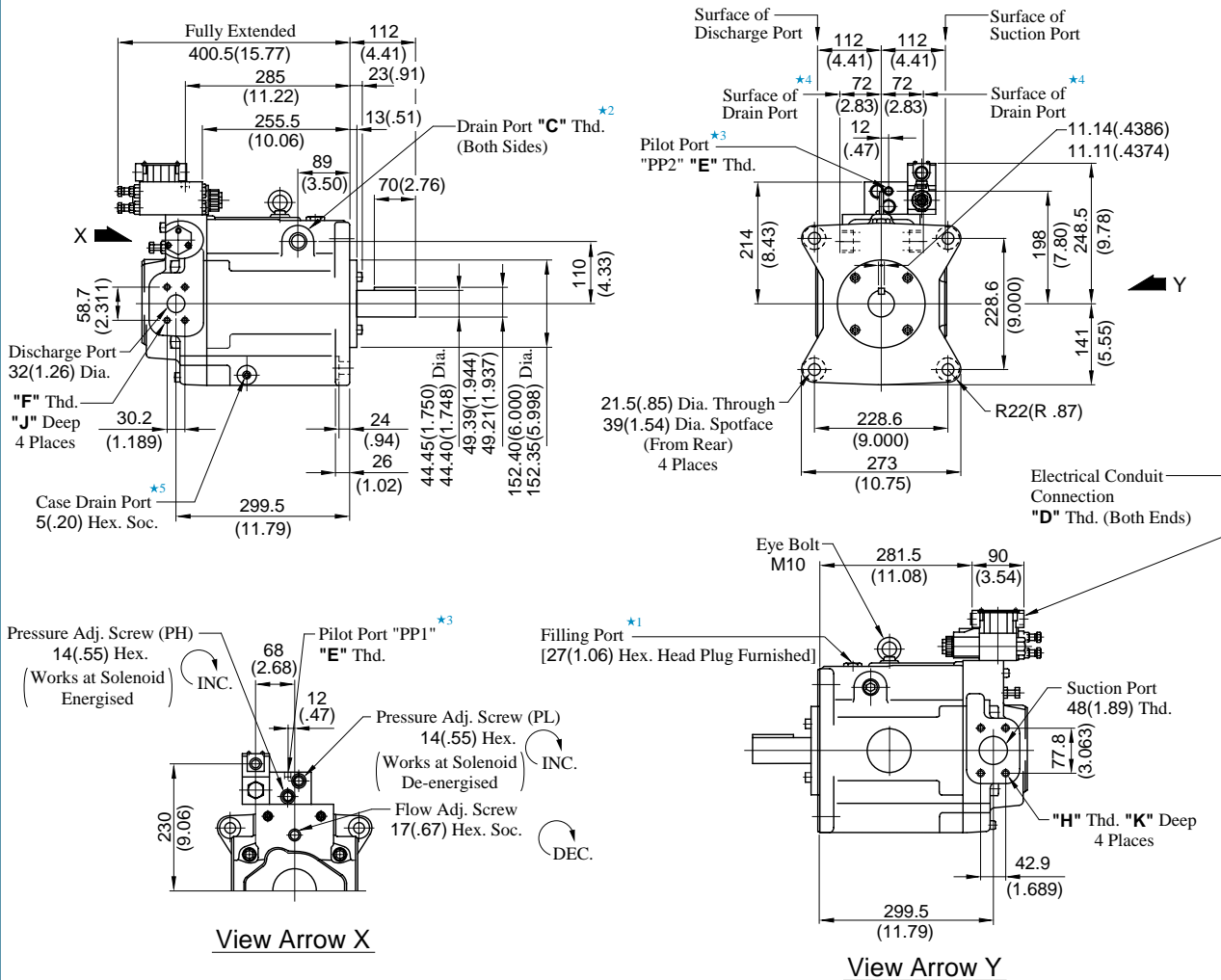

Model Numbers	"C" Thd.	"D" Thd.	"E" Thd.	"F" Thd.	"H" Thd.	"J" mm (IN.)	"K" mm (IN.)
A145-FR02S*-60	Rc 3/4	G 1/2	Rc 1/4	M10	M12	19 (.75)	19 (.75)
A145-FR02S*-6080	3/4 BSP.F	—	1/4 BSP. Tr				
A145-FR02S*-6090	3/4 NPT	1/2 NPT	1/4 NPT	7/16-14 UNC	1/2-13 UNC	20 (.79)	21 (.83)

### A145-FR02S\*-6080

Cable Departure  
Cable Applicable:  
Outside Dia. .... 8-10mm(.31-.39 IN.)  
Conductor Area ..... Not Exceeding 1.5mm<sup>2</sup>(.002 Sq. IN.)

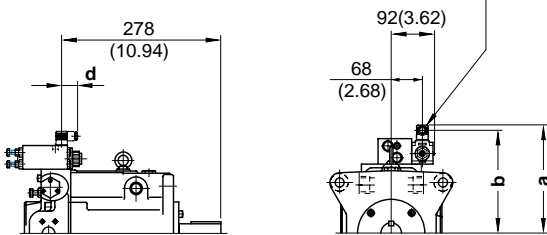

Model Numbers	mm (IN.)		
	a	b	d
A145-FR02SA*-6080	247 (9.72)	235 (9.25)	39 (1.54)
A145-FR02SD*-6080	258 (10.16)	246 (9.69)	39 (1.54)
A145-FR02SR*-6080	261 (10.28)	239.2 (9.42)	53 (2.09)

• For other dimensions, refer to 60/6090 design.

- ★ 1. Install the pump so that the "Filling Port" is at the top.
- ★ 2. Use either port of two drain ports at your option. Keep the remaining port plugged. Note that on the European Design Standard (6080 Design), only the left side, as viewed from the shaft end, of the drain port is machined.
- ★ 3. The pilot port provided is for connecting a control valve, if multistage pressure control is required.
- ★ 4. Dimensions show surface of drain port.
- ★ 5. Case drain port is available for use when draining hydraulic fluid from pump casing.

DIMENSIONS IN  
MILLIMETRES (INCHES)

#### ● Foot Mounting Type

Mounting bracket is common to that of pressure compensator model. Refer to page 23 for the dimensions of mounting bracket.

**Specifications**

Graphic Symbol

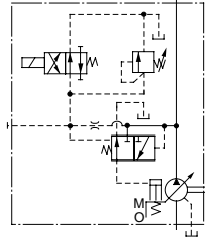

Performance Characteristics

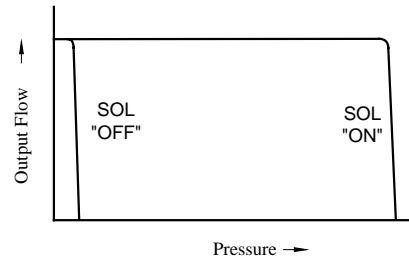

**Specifications**

Model Numbers	Geometric Displacement cm <sup>3</sup> /rev (cu. in. /rev)	Minimum Adj. Flow cm <sup>3</sup> /rev (cu. in. /rev)	Operating Pres. MPa (PSI)		Unloading Pres. MPa (PSI)	Shaft Speed Range r/min	
			Rated	Intermittent		Max.	Min.
A16-*R-03-*K-*32*	15.8 (.964)	4 (.244)	16 (2320)	21 (3050)	1.2 (170)	1800	600
A22-*R-03-*K-*32*	22.2 (1.355)	6 (.366)	16 (2320)	16 (2320)	1.2 (170)	1800	600
A37-*R-03-*K-*32*	36.9 (2.25)	10 (.61)	16 (2320)	21 (3050)	1.2 (170)	1800	600
A56-*R-03-*K-*32*	56.2 (3.43)	12 (.73)	16 (2320)	21 (3050)	1.2 (170)	1800	600
A70-*R03S*K-60*	70.0 (4.27)	30 (1.83)	25 (3630)	25 (3630)	1.2 (170)	1800	600
A90-*R03S*K-60*	91.0 (5.55)	56 (3.42)	25 (3630)	25 (3630)	1.2 (170)	1800	600
A145-*R03S*K-60*	145 (8.85)	83 (5.06)	25 (3630)	25 (3630)	1.2 (170)	1800	600

- Consult YUKEN for details.

### Model Number Designation

#### Graphic Symbols

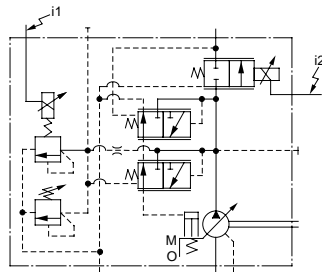

A16/A22/A37

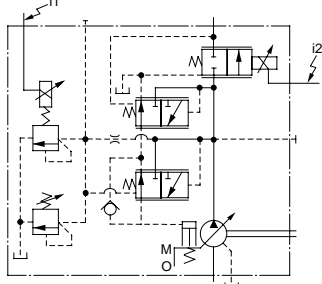

A56

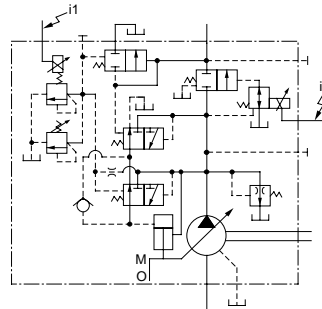

A70/A90/A145

#### Performance Characteristics

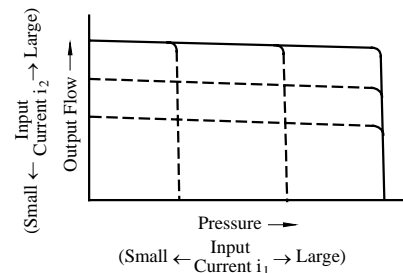

#### Model Number Designation

A56	-F	-R	-04	-C	-K	-32	*
Series Number	Mounting	Direction of Rotation	Control Type	Pres. Adj. Range MPa (PSI)	Shaft Extension	Design Number	Design Std.
<b>A16</b> (15.8 cm <sup>3</sup> /rev)	<b>F:</b> Flange Mtg.  <b>L:</b> Foot Mtg.	(Viewed from Shaft End)  <b>R: *</b> Clockwise	<b>04:</b> Proportional Electro-Hydraulic Load Sensing	<b>B:</b> 1.5 - 7 (220 - 1020) <b>C:</b> 1.5 - 16 (220 - 2320) <b>H:</b> 1.5 - 21 (220 - 3050)	<b>K:</b> Keyed Shaft	<b>32</b>	Refer to ★2
<b>A22</b> (22.2 cm <sup>3</sup> /rev)				<b>B:</b> 1.5 - 7 (220 - 1020) <b>C:</b> 1.5 - 16 (220 - 2320)		<b>32</b>	
<b>A37</b> (36.9 cm <sup>3</sup> /rev)				<b>B:</b> 2 - 7 (290 - 1020) <b>C:</b> 2 - 16 (290 - 2320) <b>H:</b> 2 - 21 (290 - 3050)		<b>32</b>	
<b>A56</b> (56.2 cm <sup>3</sup> /rev)				<b>B:</b> 2 - 7 (290 - 1020) <b>C:</b> 2 - 16 (290 - 2320) <b>H:</b> 2 - 21 (290 - 3050)		<b>32</b>	

A70	-F	R	04	C	S	-60	*
Series Number	Mounting	Direction of Rotation	Control Type	Pres. Adj. Range MPa (PSI)	Port Position	Design Number	Design Std.
<b>A70</b> (70.0 cm <sup>3</sup> /rev)	<b>F:</b> Flange Mtg.  <b>L:</b> Foot Mtg.	(Viewed from Shaft End)  <b>R: *</b> Clockwise	<b>04:</b> Proportional Electro-Hydraulic Load Sensing	<b>C:</b> 1.5 - 16 (220 - 2320) <b>H:</b> 1.5 - 21 (220 - 3050)	<b>S:</b> Side Port	<b>60</b>	Refer to ★2
<b>A90</b> (91.0 cm <sup>3</sup> /rev)						<b>60</b>	
<b>A145</b> (145 cm <sup>3</sup> /rev)						<b>60</b>	

★1. Available to supply pump with anti-clockwise rotation. Consult Yuken for details.  
 ★2. Design Standards: None ..... Japanese Standard "JIS"  
 80 ..... European Design Standard  
 90 ..... N. American Design Standard



#### ■ Pipe Flange Kits

Pipe flange kits are available.

When ordering, specify the kit number from the table below.

Pump Model Numbers	Name of Port	Pipe Flange Kit Numbers						
		Threaded Connection			Socket Welding <sup>*1</sup>		Butt Welding	
		Japanese Standard "JIS"	European Design Standard	N. American Design Standard	Japanese Standard "JIS" & European Design Standard	N. American Design Standard	Japanese Standard "JIS" & European Design Standard	N. American Design Standard
A16-*R-04 A22-*R-04	Suction	F5-06-A-10	F5-06-A-1080	F5-06-A-1090	F5-06-B-10	F5-06-B-1090	F5-06-C-10	F5-06-C-1090
	Discharge	___*2	___*2	___*2	___*2	___*2	___*2	___*2
A37-*R-04 A56-*R-04	Suction	F5-10-A-10	F5-10-A-1080	F5-10-A-1090	F5-10-B-10	F5-10-B-1090	F5-10-C-10	F5-10-C-1090
	Discharge	F5-06-A-10	F5-06-A-1080	F5-06-A-1090	F5-06-B-10	F5-06-B-1090	F5-06-C-10	F5-06-C-1090
A70-*R04	Suction	F5-12-A-10	F5-12-A-1080	F5-12-A-1090	F5-12-B-10	F5-12-B-1090	F5-12-C-10	F5-12-C-1090
	Discharge	F5-10-A-10	F5-10-A-1080	F5-10-A-1090	F5-10-B-10	F5-10-B-1090	F5-10-C-10	F5-10-C-1090
A90-*R04 A145-*R04	Suction	F5-16-A-10	F5-16-A-1080	F5-16-A-1090	F5-16-B-10	F5-16-B-1090	F5-16-C-10	F5-16-C-1090
	Discharge	F5-10-A-10	F5-10-A-1080	F5-10-A-1090	F5-10-B-10	F5-10-B-1090	F5-10-C-10	F5-10-C-1090

★1. In case of using socket welding flanges, there is a case where the operating pressure should be set lower than the normal because of strength of the flanges. Therefore, please pay cautious attention to the operating pressure when the socket welding flanges are used.

★2. Discharge port for pump model "A16" and "A22" is available only the threaded connections.

- Detail of the pipe flange kits are given in the Catalogue No. Pub. EC-3001.

#### ■ Instructions

##### ● Bleeding Air

In order to get steadily controlled pressure and flow, bleed air by loosening the air vent screw and fill solenoid armature with operating oil.

##### ● Manual Adjustment Screws

Manual adjustment screws may be used for initial running adjustment or in case of electrical failures in order to adjust pressure and flow temporarily. In case of normal use, put the manual adjustment screws back in their preset positions.

##### ● Position of Cable Departure

Position of cable departure can be changed. For details, refer to EDG-01 valve Catalogue No. Pub. EC-1302.

##### ● Connection of Surge Cut-off Valve to "A" Series Pump (For A16 to A56 Type)

If using surge cut-off valve (SF1105-A-10), connect between pilot port "PP" of this pump and port "PP" of surge cut-off valve as pilot piping (refer to drawing below).

Inside diameter of pipe should be more than 8 mm(.32 in.).

Consult Yuken of detail of surge cut-off valve.

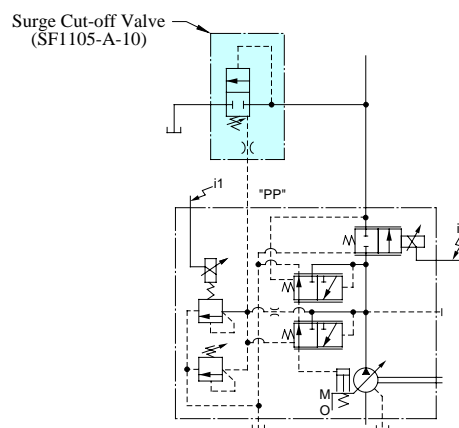

### Specifications

Descriptions		Model No.	A16	A22	A37	A56	A70	A90	A145	
Geometric Displacement		cm <sup>3</sup> /rev (cu. in./rev)	15.8 (.964)	22.2 (1.355)	36.9 (2.25)	56.2 (3.43)	70.0 (4.27)	91.0 (5.55)	145 (8.85)	
Operating Pres. MPa (PSI)	Rated <sup>*2</sup>		16 (2320)	16 (2320)	16 (2320)	16 (2320)	21 (3050)	21 (3050)	21 (3050)	
	Intermittent <sup>*1</sup>		21 (3050)	16 (2320)	21 (3050)	21 (3050)	21 (3050)	21 (3050)	21 (3050)	
Shaft Speed Range r/min	Max.		1800	1800	1800	1800	1800	1800	1800	
	Min.		600	600	600	600	600	600	600	
Flow Control	Flow Adj. Range	L/min (U.S. GPM)	1 - 28.4 (.26 - 7.5)	1 - 40 (.26 - 10.6)	1 - 66 (.26 - 17.4)	1 - 101 (.26 - 26.7)	1 - 126 (.26 - 33.3)	1 - 163 (.26 - 43.1)	2 - 261 (.53 - 69.0)	
	Min Pres. Required for Flow Adj.	MPa (PSI)	1.5 (220)	1.5 (220)	1.5 (220)	2.0 (290)	1.0 (145)	1.0 (145)	1.0 (145)	
	Differential Pres. (Discharge Pres. - Load Pres.)	MPa (PSI)	0.37 (55)				0.22 (30)			
	Step Response <sup>*5</sup> (0 → Max. Flow)	ms	70	80	120	125	100	120	210	
	Hysteresis		Less than 3% <sup>*4</sup>							
	Rated Current	mA	900	700	740	790	820	920	920	
	Coil Resistance [20°C (68°F)]	Ω	10							
Pres. Control	Pres. Adj. Range	MPa (PSI)	Refer to Model Number Designation							
	Step Response ms	t <sub>1</sub> <sup>*5</sup>	80	80	50	55	150	150	160	
		t <sub>2</sub> <sup>*5</sup>	140	90	80	80	80	120	180	
	Hysteresis		Less than 2% <sup>*4</sup>							
	Rated Current	mA	(Pres. Adj. Range) B: 770, C: 880, H: 790				C: 860 H: 765	C: 873 H: 765	C: 875 H: 755	
	Coil Resistance [20°C (68°F)]	Ω	10							
Applicable Amplifier Model <sup>*3</sup>			AME-D2-1010-*-10							
Approx. Mass kg (lbs.)	Flange Mtg.	32 (70.6)	32 (70.6)	38 (83.8)	45 (99.2)	72.5 (160)	88.5 (195)	109.5 (241)		
	Foot Mtg.	34.2 (75.4)	34.2 (75.4)	43.2 (95.3)	49.3 (109)	84.5 (186)	109 (240)	134.5 (297)		

- ★ 1. Whenever setting pressure, make sure the full cut-off pressure never exceeds the maximum intermittent pressure.
- ★ 2. When operating the pump exceeding the rated pressure, operating conditions are restricted. Refer to page 6 for the details.
- ★ 3. For detail specifications of power amplifiers, refer to Catalogue No. Pub. EC-1305.
- ★ 4. The figure mentioned in the above table are those obtained using Yuken's amplifier.
- ★ 5. Step response depends on circuit and operating conditions. Data shown in the table above is an example based on the condition right.

Model	Pres. Step Response		Loading Volume
	t <sub>1</sub>	t <sub>2</sub>	
A16, A22	1.5 → 16 MPa (220 → 2320 PSI)	16 → 1.5 MPa (2320 → 220 PSI)	High Pressure Hose 3/8" × 2 m (6.6 ft)
A37, A56	2.0 → 16 MPa (290 → 2320 PSI)	16 → 2.0 MPa (2320 → 290 PSI)	High Pressure Hose 3/4" × 2 m (6.6 ft)
A70, A90 A145	3.0 → 16 MPa (435 → 2320 PSI)	16 → 3.0 MPa (2320 → 435 PSI)	High Pressure Hose 1-1/4" × 2 m (6.6 ft)

### Typical Pump Characteristics

Typical Performance Characteristics at Viscosity 20 mm<sup>2</sup>/s (100 SSU) [ISO VG32 Oils, 50°C (122°F)]

#### Full Cut-off Pres. vs. Input Current

##### ● A16/A22/A37/A56

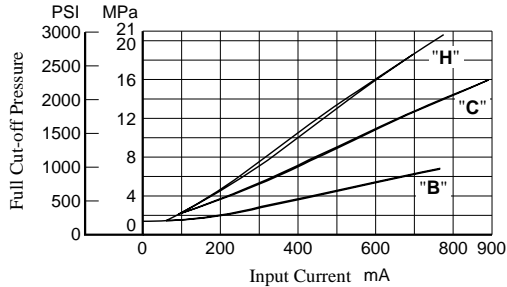

Note: Pressure adjustment range "H" is not available for A22.

##### ● A70/A90/A145

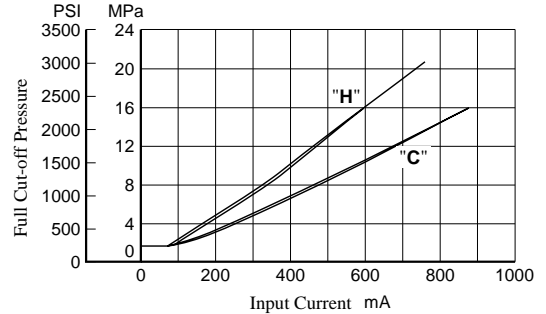

#### Output Flow vs. Input Current

##### ● A16

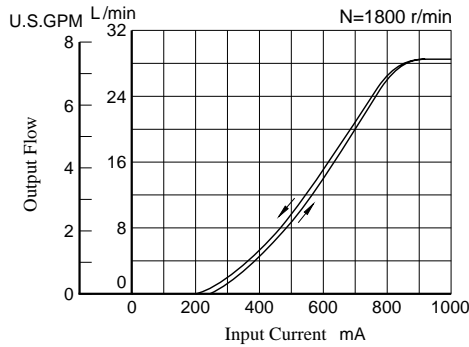

##### ● A37

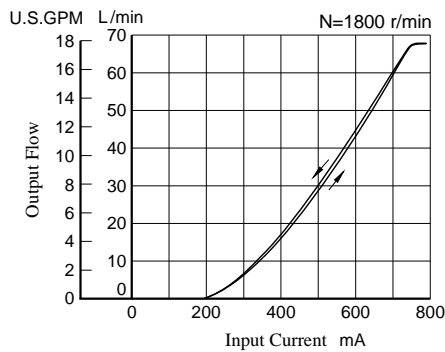

##### ● A90

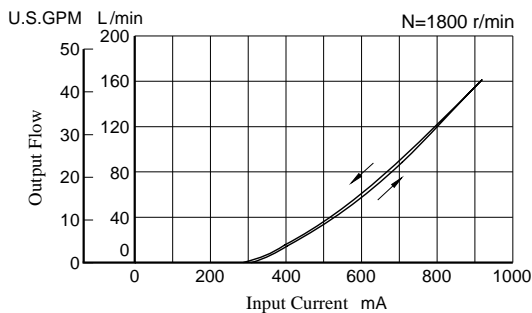

##### ● A22

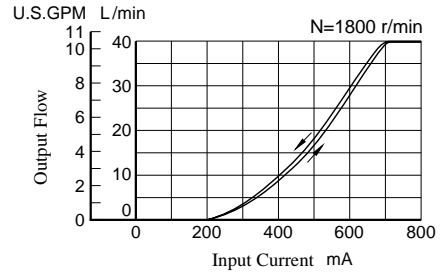

##### ● A56

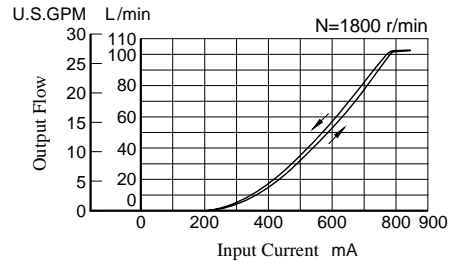

##### ● A70

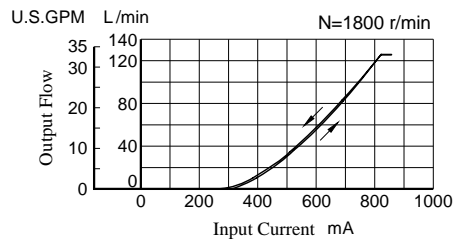

##### ● A145

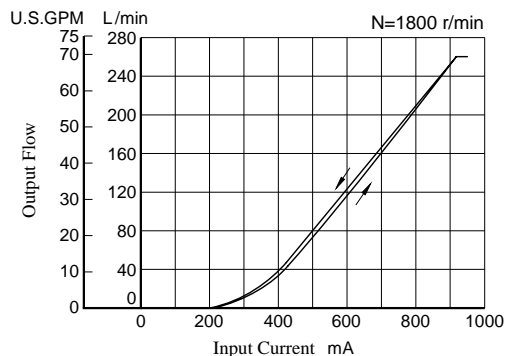

### Installation Drawing

Flange Mtg : A16-F-R-04-*\**-K-32/3280/3290  
A22-F-R-04-*\**-K-32/3280/3290

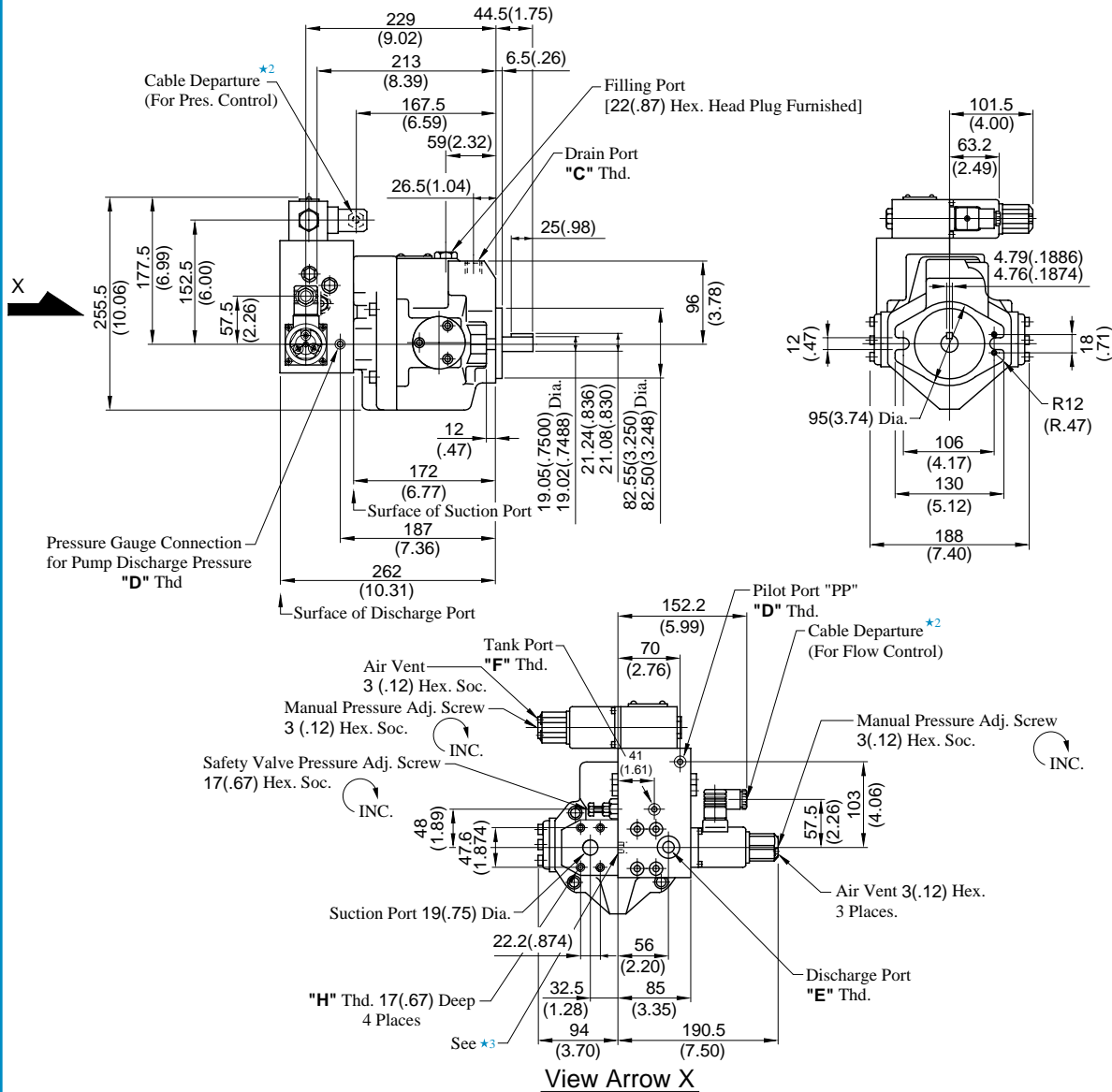

Model Numbers	"C" Thd.	"D" Thd.	"E" Thd.	"F" Thd.	"H" Thd.
A16/A22-F-R-04- <i>*</i> -K-32	Rc 3/8	Rc 1/4	G 3/8 <sup>*1</sup>	Rc 1/4	M10
A16/A22-F-R-04- <i>*</i> -K-3280	3/8 BSP.F	1/4 BSP.Tr	3/8 BSP.F	1/4 BSP.F	
	3/8 NPT	1/4 NPT	3/8 NPT	1/4 NPT	3/8-16 UNC

**\*1.** Detail of Discharge Ports  
[For Japanese Standard]

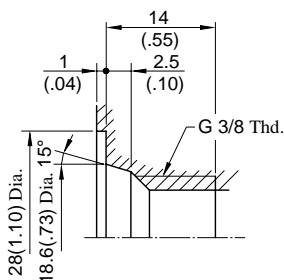

**\*2.** Cable Applicable:  
Outside Dia.....8-10 mm (.31-.39 IN.)  
Conductor Area.....Not Exceeding 1.5 mm<sup>2</sup> (.002 Sq. IN.)

**\*3.** Do not touch the screw because it is adjusted at the time of shipment.

**DIMENSIONS IN  
MILLIMETRES (INCHES)**

#### ● Foot Mounting Type

Mounting bracket is common to that of pressure compensator model.  
Refer to page 18 for the dimensions of mounting bracket.

Flange Mtg. : A37-F-R-04-\*K-32/3280/3290

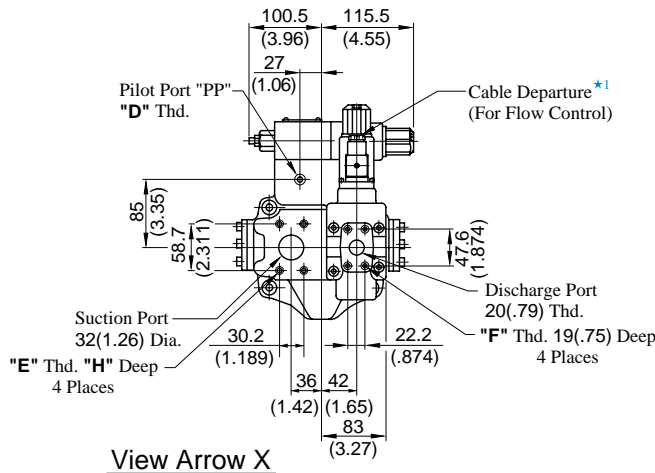
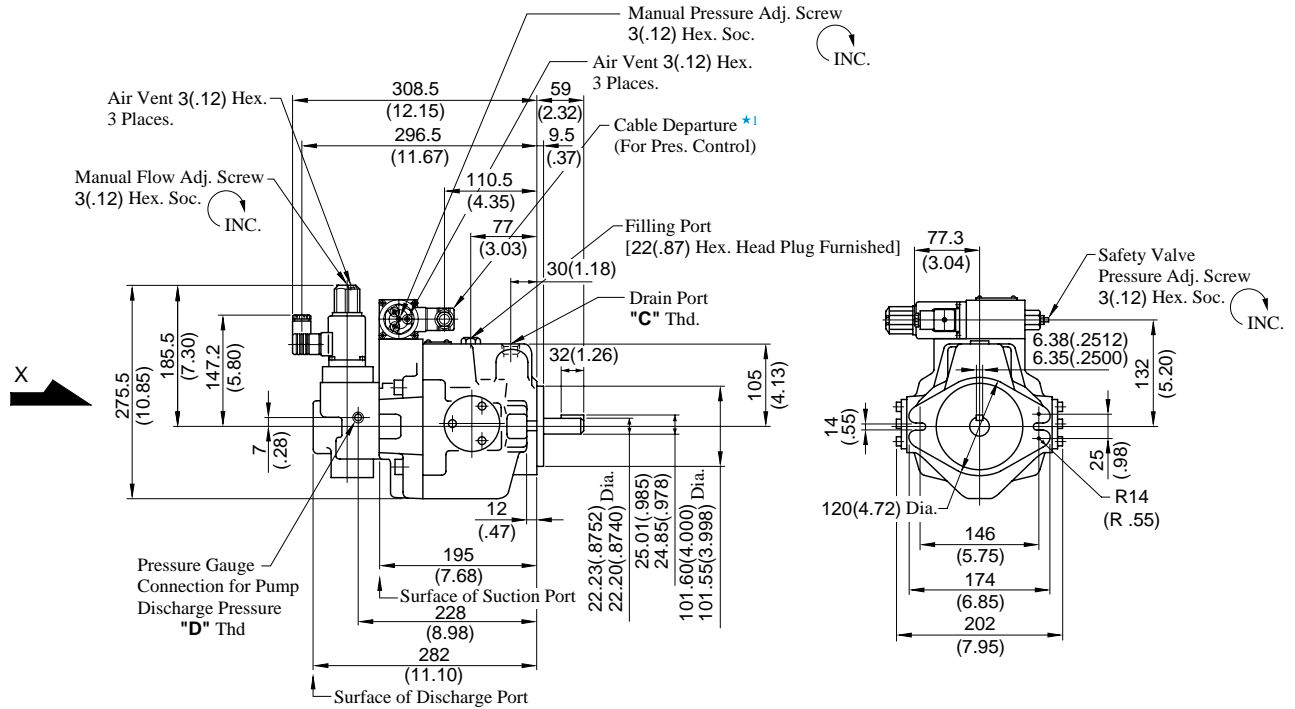

★ 1. Cable Applicable:  
Outside Dia.....8-10 mm (.31-.39 IN.)  
Conductor Area.....Not Exceeding 1.5 mm<sup>2</sup> (.002 Sq. IN.)

View Arrow X

Model Numbers	"C" Thd.	"D" Thd.	"E" Thd.	"F" Thd.	"H" mm (IN.)
A37-F-R-04-*K-32	Rc 1/2	Rc 1/4	M10	M10	19 (.75)
A37-F-R-04-*K-3280	1/2 BSP.F	1/4 BSP.Tr			
A37-F-R-04-*K-3290	1/2 NPT	1/4 NPT	7/16-14 UNC	3/8-16 UNC	20 (.79)

DIMENSIONS IN  
MILLIMETRES (INCHES)

Foot Mtg. : A37-L-R-04-\*K-32/3280/3290

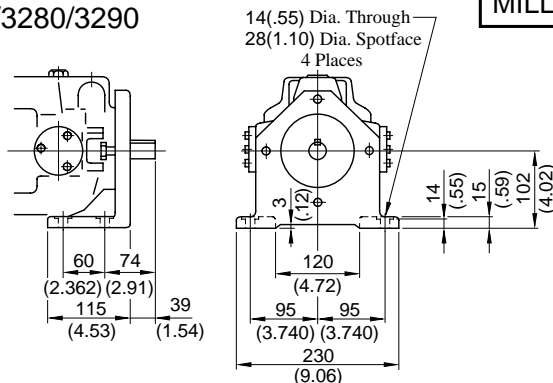

• For other dimensions, refer to "Flange Mtg."

### Installation Drawing

Flange Mtg. : A56-F-R-04-*\**-K-32/3280/3290

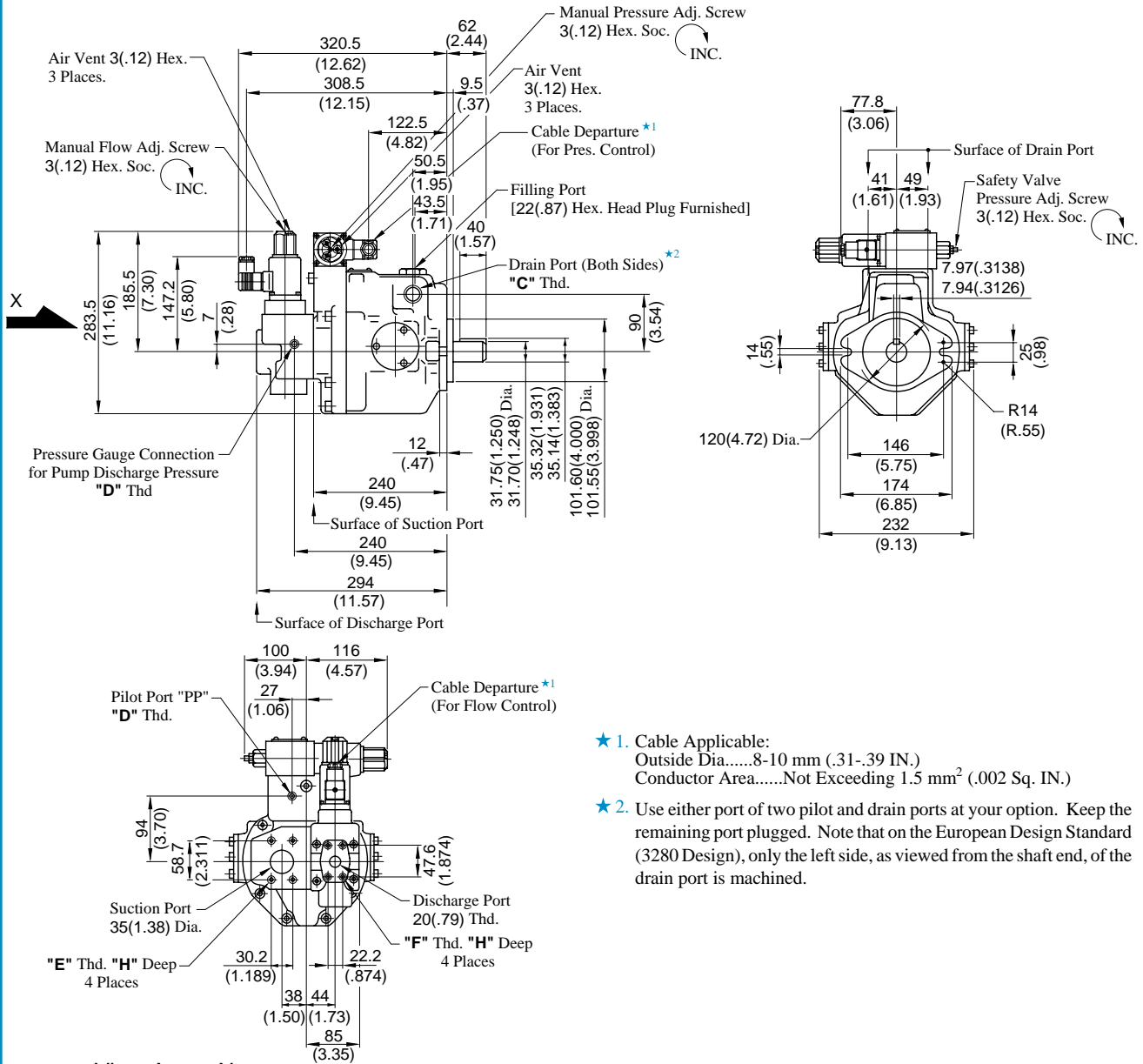

- ★ 1. Cable Applicable:  
Outside Dia.....8-10 mm (.31-.39 IN.)  
Conductor Area.....Not Exceeding 1.5 mm<sup>2</sup> (.002 Sq. IN.)
- ★ 2. Use either port of two pilot and drain ports at your option. Keep the remaining port plugged. Note that on the European Design Standard (3280 Design), only the left side, as viewed from the shaft end, of the drain port is machined.

View Arrow X

Model Numbers	"C" Thd.	"D" Thd.	"E" Thd.	"F" Thd.	"H" mm (IN.)
A56-F-R-04- <i>*</i> -K-32	Rc 3/4	Rc 1/4	M10	M10	19 (.75)
A56-F-R-04- <i>*</i> -K-3280	3/4 BSP.F	1/4 BSP.Tr			
A56-F-R-04- <i>*</i> -K-3290	3/4 NPT	1/4 NPT	7/16-14 UNC	3/8-16 UNC	20 (.79)

DIMENSIONS IN  
MILLIMETRES (INCHES)

Foot Mtg. : A56-L-R-04-*\**-K-32/3280/3290

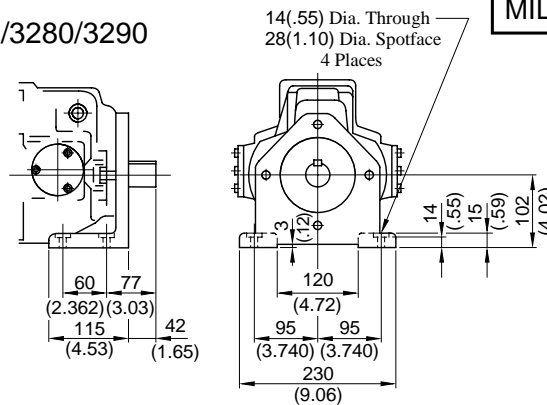

• For other dimensions, refer to "Flange Mtg.".

Flange Mtg. : A70-FR04\*S-60/6080/6090

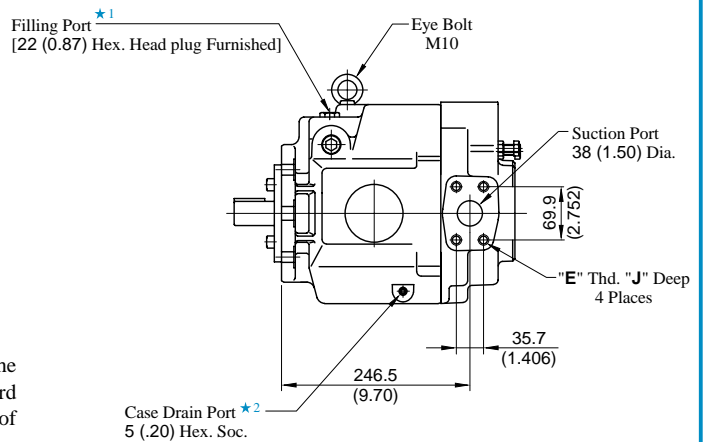
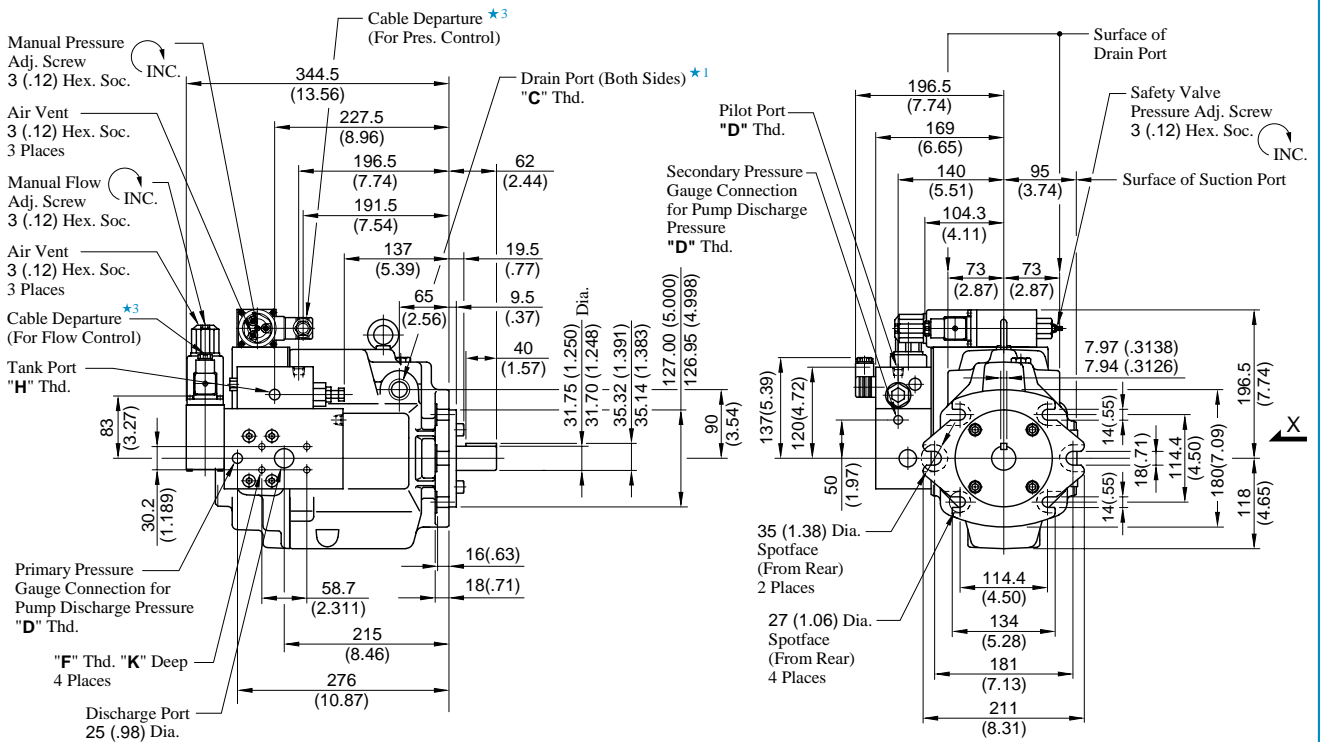

View Arrow X

- ★ 1. Use either port of two pilot and drain ports at your option. Keep the remaining port plugged. Note that on the European Design Standard (6080 Design), only the left side, as viewed from the shaft end, of the drain port is machined.
- ★ 2. Case drain port is available for use when draining hydraulic fluid from pump casing.
- ★ 3. Cable Applicable:  
Outside Dia.....8-10 mm (.31-.39 IN.)  
Conductor Area.....Not Exceeding 1.5 mm<sup>2</sup> (.002 Sq. IN.)

Model Numbers	"C" Thd.	"D" Thd.	"E" Thd.	"F" Thd.	"H" Thd.	J mm (IN.)	K mm (IN.)
A70-FR04*S-60	Rc 3/4	Rc 1/4	M12	M10	Rc 3/8	19 (.75)	17 (.67)
A70-FR04*S-6080	3/4 BSP.F	1/4 BSP. Tr			3/8 BSP. F		
A70-FR04*S-6090	3/4 NPT	1/4 NPT	1/2-13 UNC	7/16-14 UNC	3/8 NPT	21 (.83)	20 (.79)

DIMENSIONS IN  
MILLIMETRES (INCHES)

#### ● Foot Mounting Type

Mounting bracket is common to that of pressure compensator model.  
Refer to page 21 for the dimensions of mounting bracket.

Flange Mtg. : A90-FR04\*S-60/6080/6090

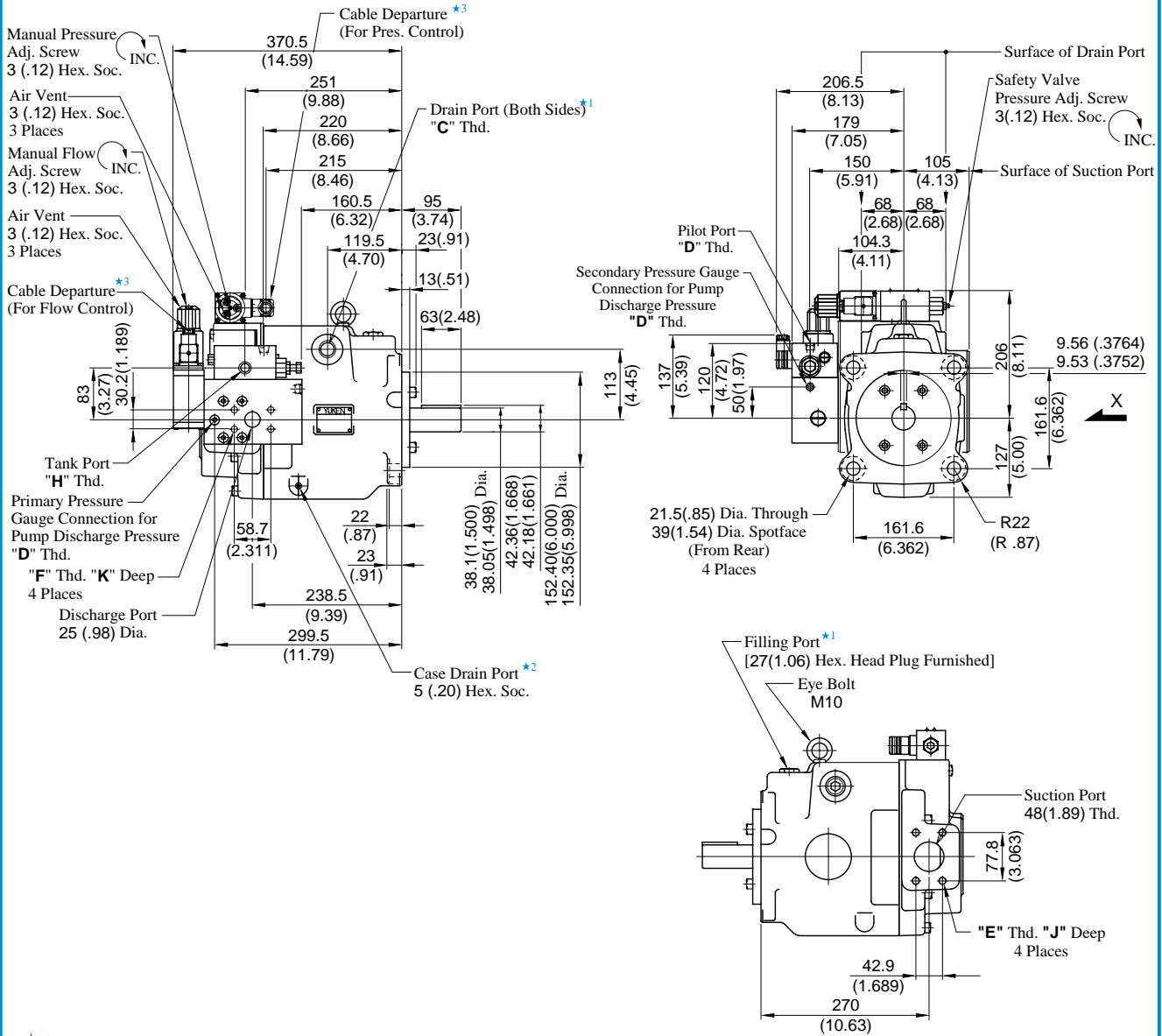

- ★ 1. Use either port of two pilot and drain ports at your option. Keep the remaining port plugged. Note that on the European Design Standard (6080 Design), only the left side, as viewed from the shaft end, of the drain port is machined.
- ★ 2. Case drain port is available for use when draining hydraulic fluid from pump casing.
- ★ 3. Cable Applicable:  
Outside Dia.....8-10 mm (.31-.39 IN.)  
Conductor Area.....Not Exceeding 1.5 mm<sup>2</sup> (.002 Sq. IN.)

View Arrow X

Model Numbers	"C" Thd.	"D" Thd.	"E" Thd.	"F" Thd.	"H" Thd.	J mm (IN.)	K mm (IN.)
A90-FR04*S-60	Rc 3/4	Rc 1/4	M12	M10	Rc 3/8	19 (.75)	17 (.67)
A90-FR04*S-6080	3/4 BSP.F	1/4 BSP. Tr			3/8 BSP. F		
A90-FR04*S-6090	3/4 NPT	1/4 NPT	1/2-13 UNC	7/16-14 UNC	3/8 NPT	21 (.83)	20 (.79)

DIMENSIONS IN  
MILLIMETRES (INCHES)

#### ● Foot Mounting Type

Mounting bracket is common to that of pressure compensator model. Refer to page 22 for the dimensions of mounting bracket.



Flange Mtg. : A145-FR04\*S-60/6080/6090

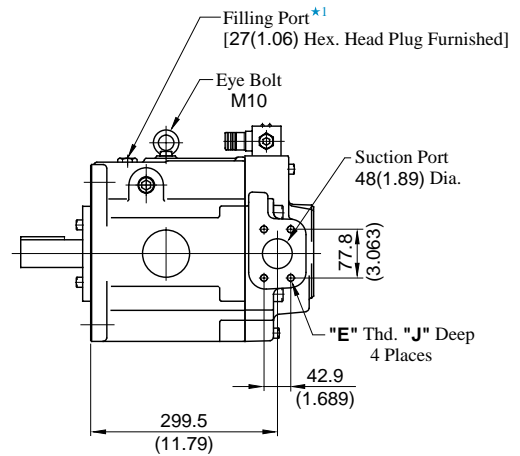
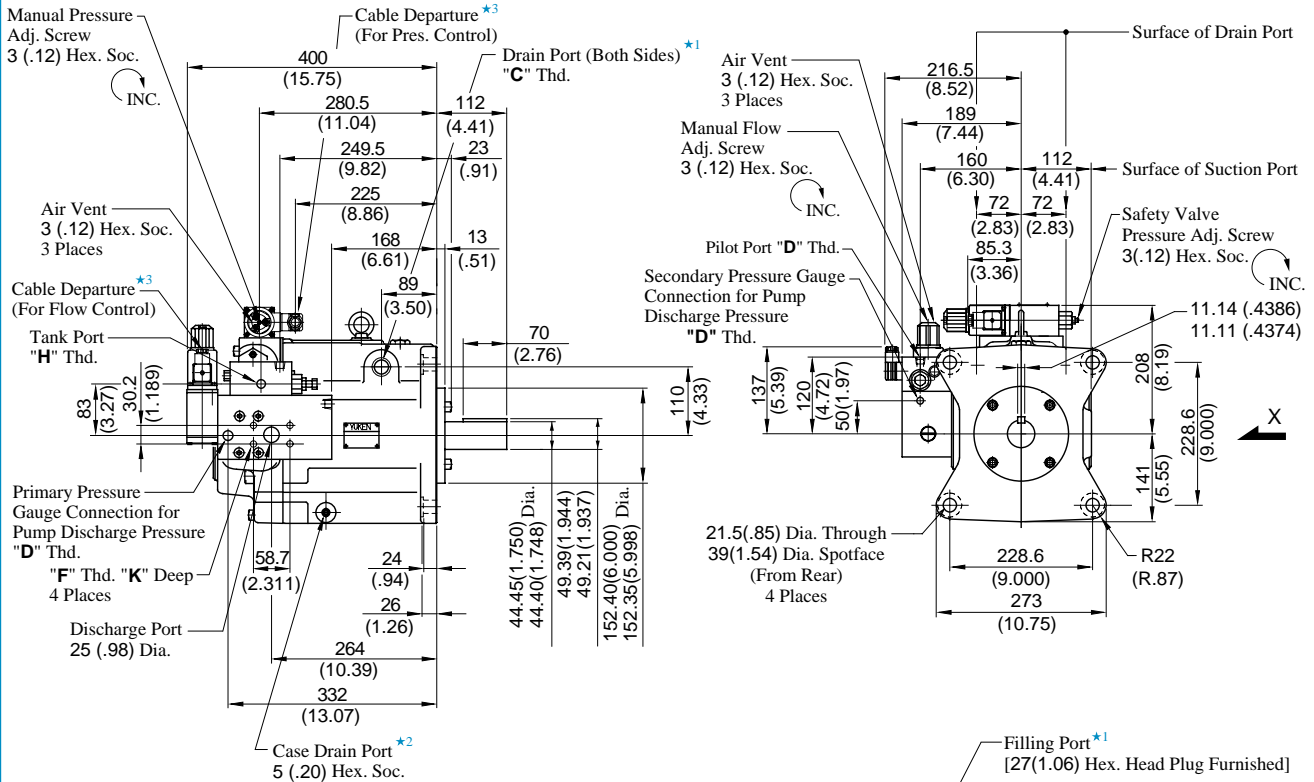

View Arrow X

- ★ 1. Use either port of the two pilot and drain ports at your option. Keep the remaining port plugged. Note that on the European Design Standard (6080 Design), only the left side, as viewed from the shaft end, of the drain port is machined.
- ★ 2. Case drain ports are available for use when draining hydraulic fluid from pump casing.
- ★ 3. Cable Applicable:  
Outside Dia.....8-10 mm (.31-.39 IN.)  
Conductor Area.....Not Exceeding 1.5 mm<sup>2</sup> (.002 Sq. IN.)

Model Numbers	"C" Thd.	"D" Thd.	"E" Thd.	"F" Thd.	"H" Thd.	J mm (IN.)	K mm (IN.)
A145-FR04*S-60	Rc 3/4	Rc 1/4	M12	M10	Rc 3/8	19 (.75)	17 (.67)
A145-FR04*S-6080	3/4 BSP.F	1/4 BSP. Tr			3/8 BSP. F		
A145-FR04*S-6090	3/4 NPT	1/4 NPT	1/2-13 UNC	7/16-14 UNC	3/8 NPT	21 (.83)	20 (.79)

DIMENSIONS IN  
MILLIMETRES (INCHES)

#### ● Foot Mounting Type

Mounting bracket is common to that of pressure compensator model.  
Refer to page 23 for the dimensions of mounting bracket.

### Model Number Designation

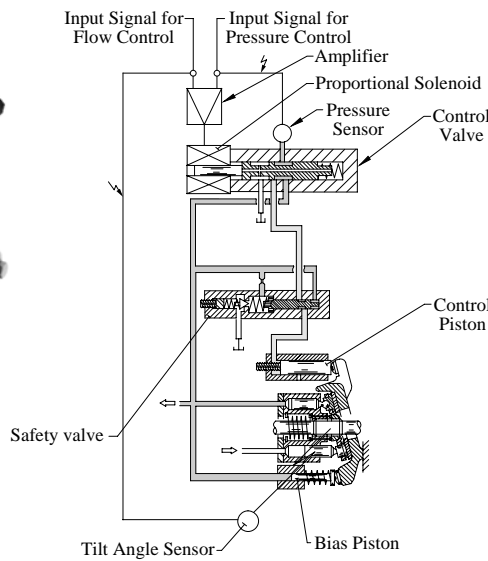

### Performance Characteristics

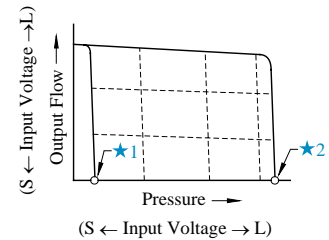

- ★1. Unloading pressure when input signal is 0 V.
- ★2. Safety valve setting pressure

### Graphic Symbols

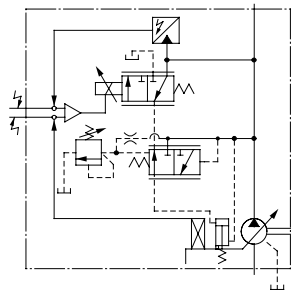

A16/A22/A37/A56

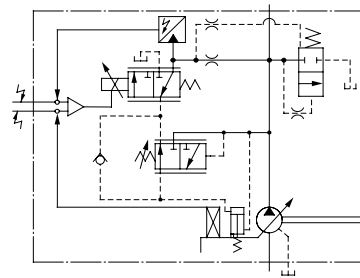

A70/A90/A145

### Model Number Designation

A70	-F	R	04E	16	M	A	-60	-60	*
Series Number	Mounting	Direction of Rotation	Control Type	Control Pressure at Input Signal is 5 V	Unit of Control Pressure	Type of Outboard Pump	Compensation Number	Design Number	Design Std.
A16 (15.8 cm <sup>3</sup> /rev)	F: Flange Mtg.	(Viewed from Shaft End)	04E: Proportional Pressure & Flow Control Type	Use the same measure of the control pressure as shown on the right, 6.9 MPa (70 kgf/cm <sup>2</sup> , 1000 PSI) specify within the range of maximum operating pressure	None: kgf/cm <sup>2</sup> M: MPa P: PSI	—	06	42	Refer to ★4
A22 (22.2 cm <sup>3</sup> /rev)							11	42	
A37 (36.9 cm <sup>3</sup> /rev)							01	42	
A56 (56.2 cm <sup>3</sup> /rev)							02	42	
A70 (70.0 cm <sup>3</sup> /rev)	L: Foot Mtg.	R: Clockwise (Normal)	★1			Outboard pump models A: A16,A22 PV2R1 B: A37 PV2R2	60	60	
A90 (91.0 cm <sup>3</sup> /rev)							60	60	
A145 (145.0 cm <sup>3</sup> /rev)							60	60	

- ★1. Available to supply pump with anti-clockwise rotation. Consult Yuken for details.
- ★2. Models A70/A90/A145 can be used as double pumps. Chose either A or B suitable for the outboard pump. For the mounting of outboard pumps, make inquires separately. If you use these models as single pumps, generally specify "A".
- ★3. Amplifier Compensation Number may differ according to the main machine conditions. Consult Yuken for detail
- ★4. Design Standards: None ..... Japanese Standard "JIS"  
80 ..... European Design Standard  
90 ..... N. American Design Standard

## Specifications

Descriptions		Model Numbers	A16	A22	A37	A56	A70	A90	A145
Geometric Displacement	cm <sup>3</sup> /rev (cu. in./rev)		15.8 (.964)	22.2 (1.355)	36.9 (2.25)	56.2 (3.43)	70.0 (4.27)	91.0 (5.55)	145.0 (8.85)
Operating Pres. MPa (PSI)	Rated <sup>*2</sup>		16 (2320)	16 (2320)	16 (2320)	16 (2320)	25 (3630)	25 (3630)	25 (3630)
	Intermittent <sup>*1</sup>		21 (3050)	16 (2320)	21 (3050)	21 (3050)	28 (4060)	28 (4060)	28 (4060)
Shaft Speed Range		r/min	600 - 1800						
Flow Control	Max. Flow <sup>*3</sup>	L/min (U.S. GPM)	28.4 (7.5)	40.0 (10.6)	66.4 (17.5)	101.0 (26.7)	126.0 (33.3)	163.0 (43.1)	261.0 (69.0)
	Min. Pres. Required for Flow Adj.	MPa (PSI)	2.0 (290) <sup>*4</sup>						
	Hysteresis		Less than 1 %						
	Repeatability		Less than 1 %						
	Input Signal		Max. Flow / 5 V DC						
Pressure Control	Min. Adjustment Pressure	MPa (PSI)	0.7 (100)						
	Hysteresis		Less than 1 %						
	Repeatability		Less than 1 %						
	Input Signal		Specified Control Pressure / 5 V DC						
Coil Resistance		Ω [ @ 20°C (68 °F) ]	10						
Input Impedance			Flow Control : 10kΩ Pres. Control : 10kΩ						
Supply Electric Power			24 V DC (21 - 28 V Included Ripple)						
Power Input (Max.)		W	30						
Output Signal	Flow		5 V DC/Max. Flow						
	Pressure		5 V DC/Specified Control Pressure						
Alarm Signal Output (Open Collector)			Voltage : Max. 30 V DC Current : Max. 40 mA						
Ambient Temperature		°C (°F)	0 - 50 (32 - 122) (With Circulated Air)						
Approx. Mass kg (lbs.)	Flange Mtg.		20.5 (45.2)	20.5 (45.2)	32.0 (70.6)	39.0 (86.0)	64.0 (141)	76.5 (169)	96.4 (213)
	Foot Mtg.		22.7 (50.1)	22.7 (50.1)	36.3 (80.0)	43.3 (95.5)	76.0 (168)	97.0 (214)	121.4 (268)

- ★1. Whenever setting pressure, make sure the full cut-off pressure never exceeds the maximum intermittent pressure.
- ★2. When operating the pump exceeding the rated pressure, operating conditions are restricted.  
Refer to page 6 for the details.
- ★3. Maximum flow differs to shaft speed.  
The value listed above indicates shaft speed of 1800 r/min.  
For other shaft speed calculate by the ratio of shaft speed.
- ★4. To secure the required minimum pressure, special sequence valves are available, to be directly installed at the discharge port of the pump. Consult Yuken for details.

## Pipe Flange Kits

For Pipe flange, refer to form of pressure compensator type on page 7.

## Instructions

### Input Signal

The pump is on unload condition when the pump is operated without input signal voltage.

### Electric Source

Always turn off electric source whenever the connector for swash plate tilt angle sensor is removed.

### Compensation of Pump Maximum Regulated Flow at Frequency

If the same maximum flow is required at 50 Hz or 60 Hz, connect short plug in the amplifier to 60 Hz at the place where supplied frequency is 60 Hz. At this condition, maximum flow comes to the same value at 50 Hz.

If short plug is used at 60 Hz without making the change, maximum flow increased in proportion to frequency.

### Painting on Amp. Box and Solenoid

To maintain suitable radiation effect, the amp. Box and the solenoid of the control valve should not be painted.

### Typical Pump Characteristics

#### Output Flow vs. Input Signal

##### ● A16

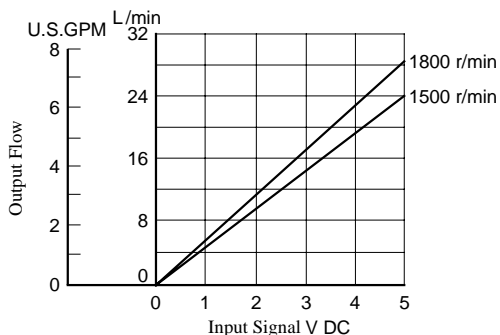

##### ● A56

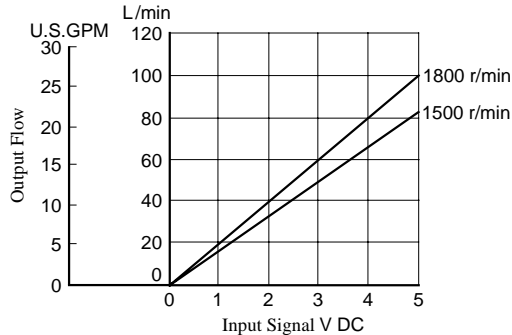

##### ● A22

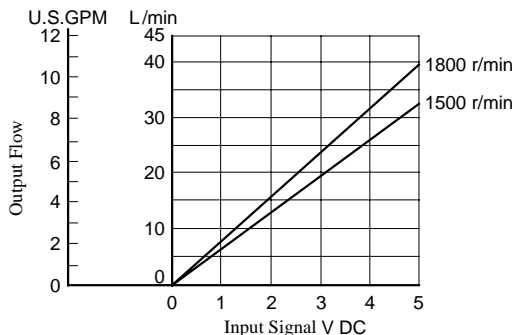

##### ● A70

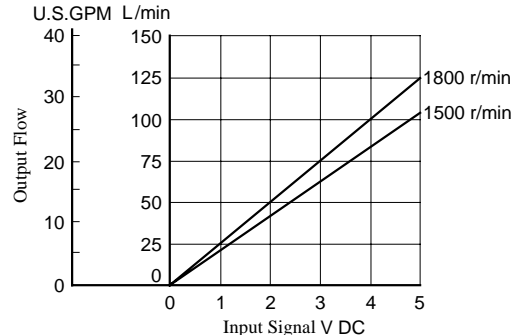

##### ● A37

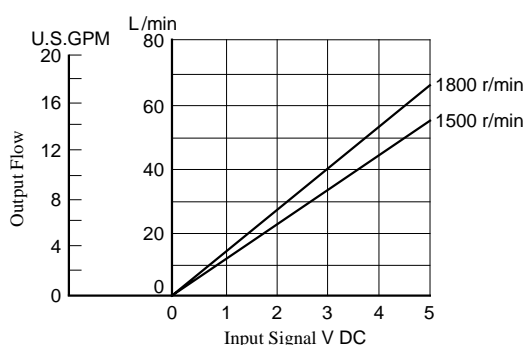

##### ● A90

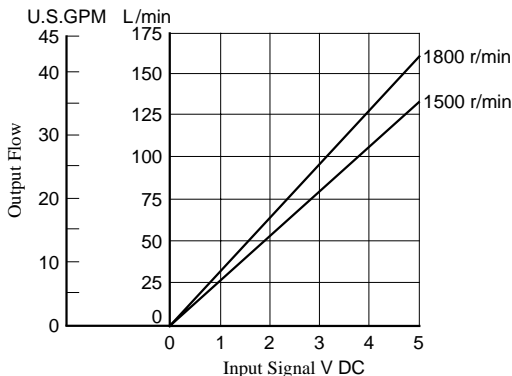

Note: Pump characteristics at 1800 r/min is the same as those at 1500 r/min where frequency is compensated. (Refer to page 48.)

##### ● A145

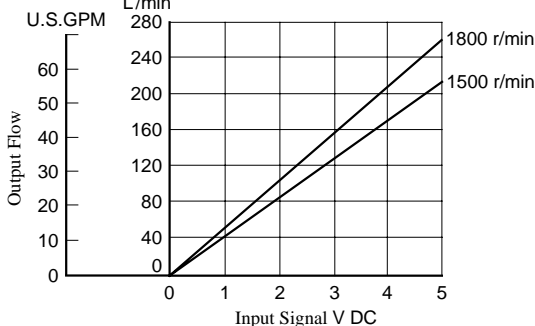

#### Full Cut-off Pres. vs. Input Signal

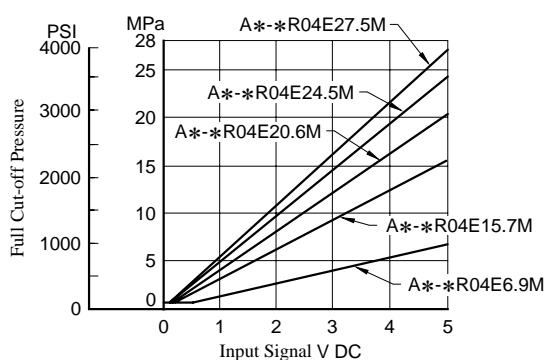

Refer to page 10 to 16 for performance characteristics of pressure compensator type excluding characteristics appeared on this catalogue.

Flange Mtg. : A16-FR04E\*-06-42/4280/4290  
A22-FR04E\*-11-42/4280/4290

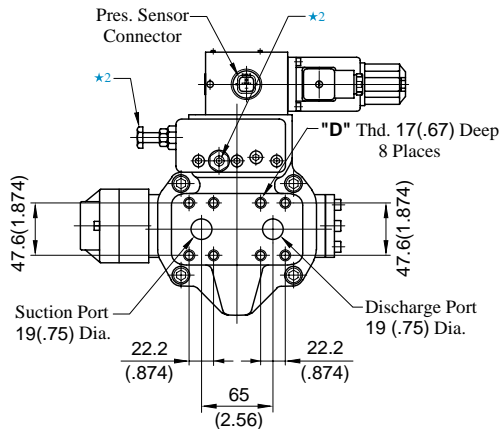
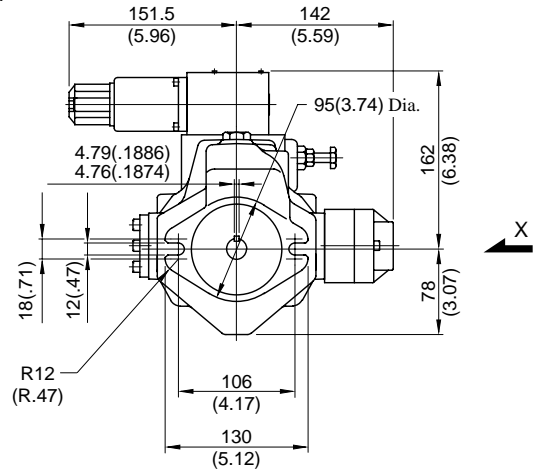
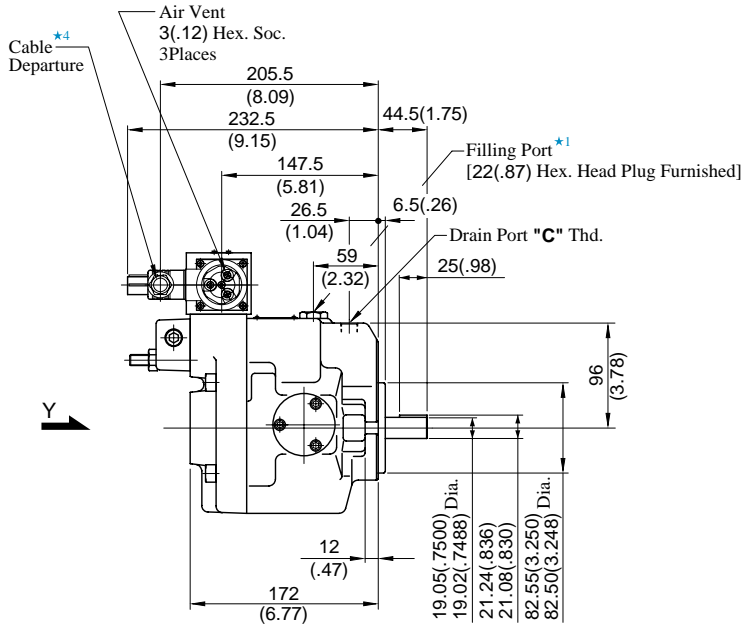

View Arrow Y

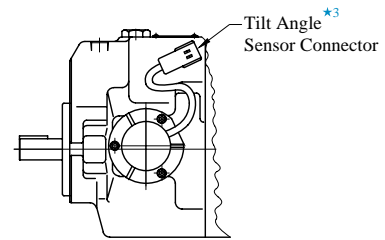

View Arrow X

- ★ 1. Install the pump so that the "Filling Port" is at the top.
- ★ 2. Do not touch the screw because it is adjusted at the time of shipment.
- ★ 3. For cable connection with amplifiers, see page 56.
- ★ 4. Cable Applicable:  
Outside Dia. .... 8-10mm (.31-.39 IN.)  
Conductor Area .....Not Exceeding 1.5mm<sup>2</sup> (.002 Sq. IN.)

Model Numbers	"C" Thd.	"D" Thd.
A16/A22-FR04E*-*-42	Rc 3/8	M10
A16/A22-FR04E*-*-4280	3/8 BSP.F	
A16/A22-FR04E*-*-4290	3/8 NPT	3/8-16 UNC

DIMENSIONS IN  
MILLIMETRES (INCHES)

#### ● Foot Mounting Type

Mounting bracket is common to that of pressure compensator model.  
Refer to page 18 for the dimensions of mounting bracket.

### Installation Drawing

Flange Mtg. : A37-FR04E\*-01-42/4280/4290

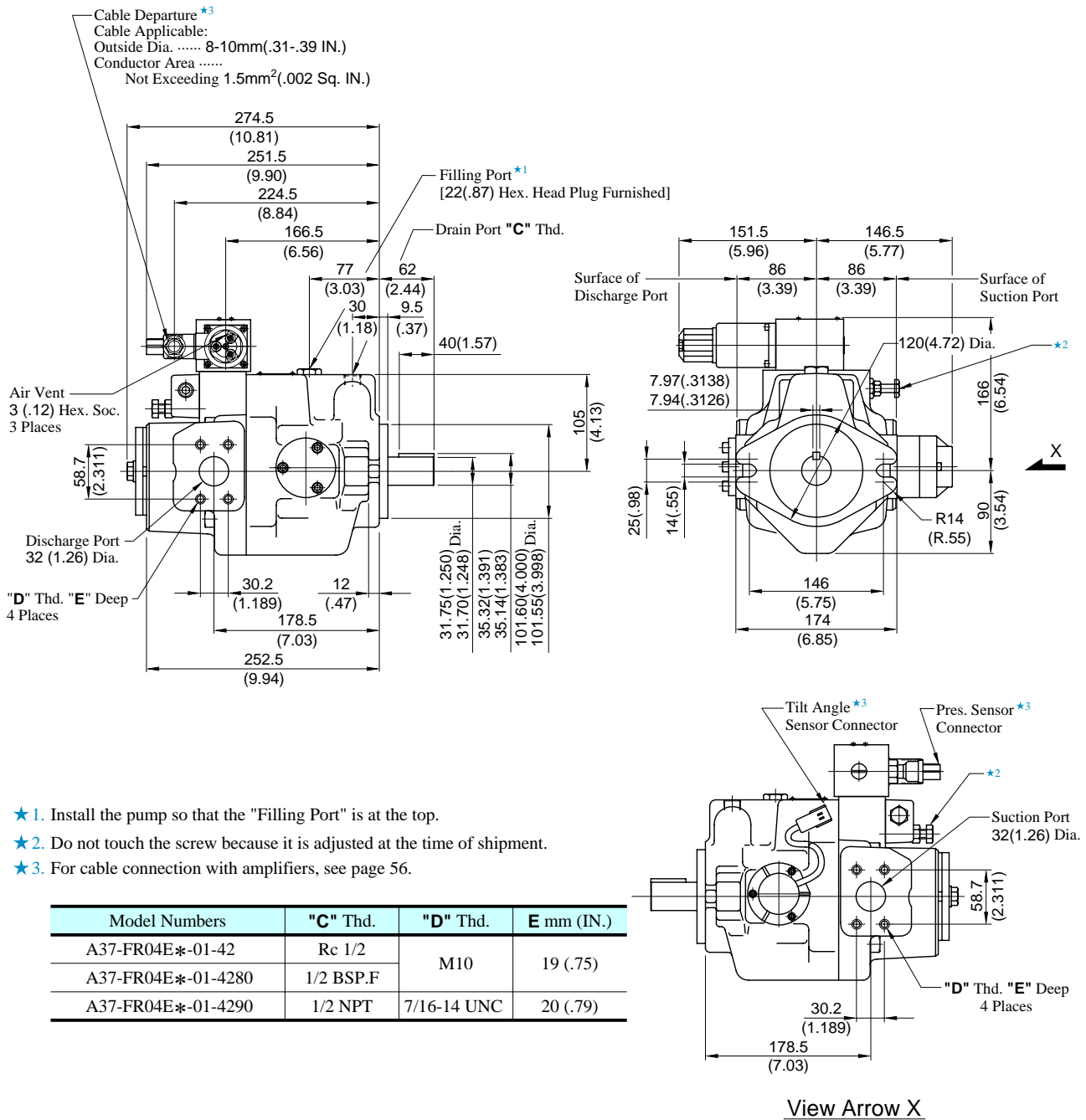

DIMENSIONS IN  
MILLIMETRES (INCHES)

### ● Foot Mounting Type

Mounting bracket is common to that of pressure compensator model.  
Refer to page 19 for the dimensions of mounting bracket.

Flange Mtg. : A56-FR04E\*-02-42/4280/4290

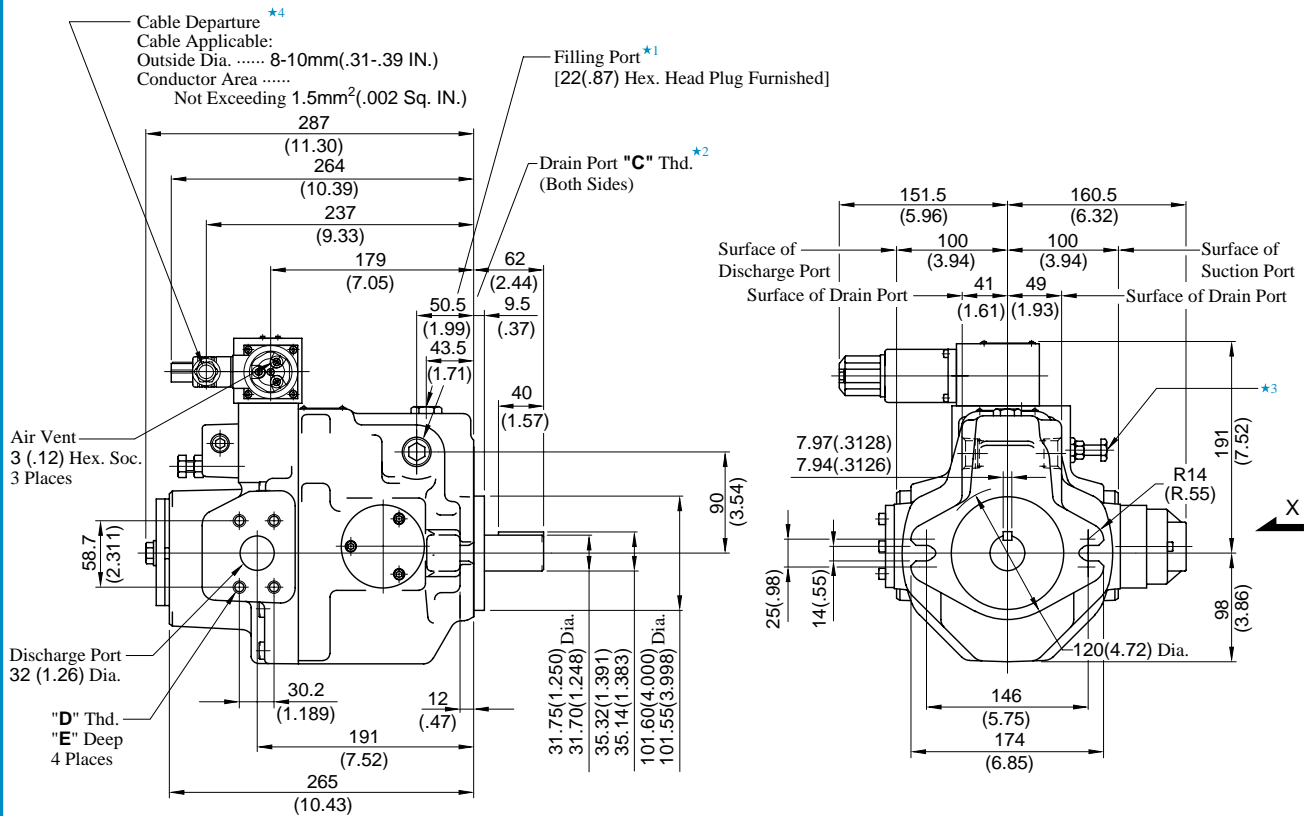

- ★1. Install the pump so that the "Filling Port" is at the top.
- ★2. Use either port of two drain ports at your option. Keep the remaining port plugged. Note that on the European design standard (4280 Design), only the left side, as viewed from the shaft end, of the drain port is machined.
- ★3. Do not touch the screw because it is adjusted at the time of shipment.
- ★4. For cable connection with amplifiers, see page 56.

Model Numbers	"C" Thd.	"D" Thd.	E mm (IN.)
A56-FR04E*-02-42	Rc 3/4	M10	19 (.75)
A56-FR04E*-02-4280	3/4 BSP.F		
A56-FR04E*-02-4290	3/4 NPT	7/16-14 UNC	20 (.79)

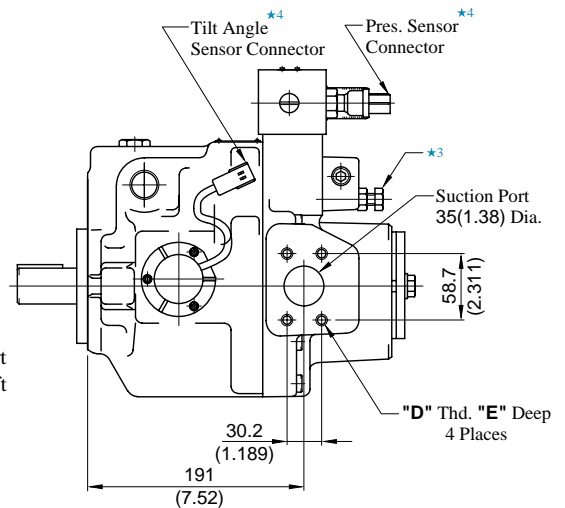

View Arrow X

DIMENSIONS IN  
MILLIMETRES (INCHES)

#### ● Foot Mounting Type

Mounting bracket is common to that of pressure compensator model.  
Refer to page 20 for the dimensions of mounting bracket.

### Installation Drawing

Flange Mtg. : A70-FR04E\*\*-60-60/6080/6090

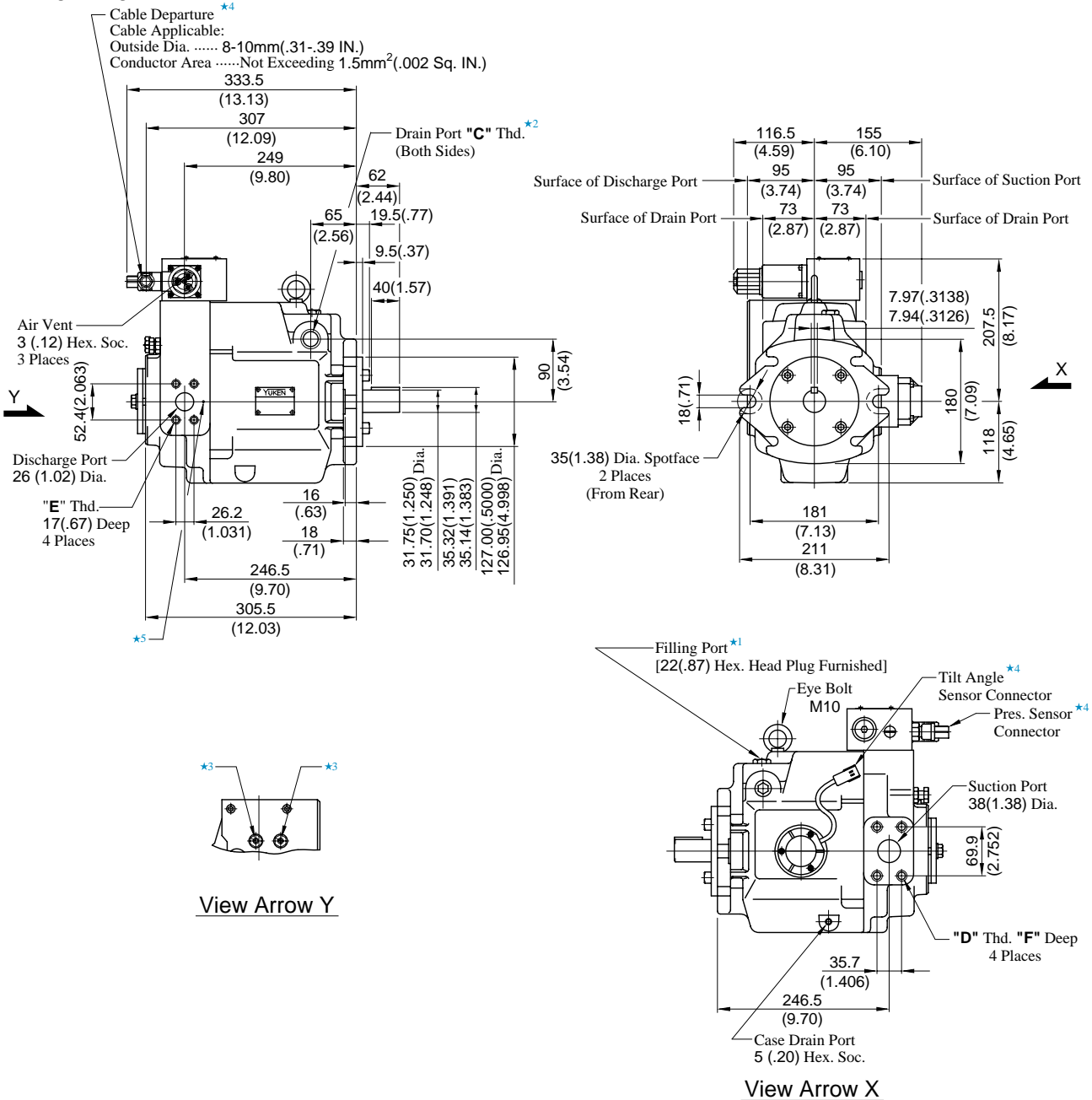

- ★ 1. Install the pump so that the "Filling Port" is at the top.
- ★ 2. Use either port of two drain ports at your option. Keep the remaining port plugged. Note that on the European design standard (6080 Design), only the left side, as viewed from the shaft end, of the drain port is machined.
- ★ 3. Do not touch the screw because it is adjusted at the time of shipment.
- ★ 4. For cable connection with amplifiers, see page 56.
- ★ 5. If you do not use the special sequence valve, plug the port (FP-SC-1/32)

Model Numbers	"C" Thd.	"D" Thd.	"E" Thd.	Dimensions mm (IN.)
				F
A70-FR04E**-60-60	Rc 3/4	M12	M10	19 (.75)
A70-FR04E**-60-6080	3/4 BSP.F			
A70-FR04E**-60-6090	3/4 NPT	1/2-13 UNC	3/8-16 UNC	21 (.83)

DIMENSIONS IN  
MILLIMETRES (INCHES)

● **Foot Mounting Type**  
 Mounting bracket is common to that of pressure compensator model.  
 Refer to page 21 for the dimensions of mounting bracket.



Flange Mtg. : A90-FR04E\*\*-60-60/6080/6090

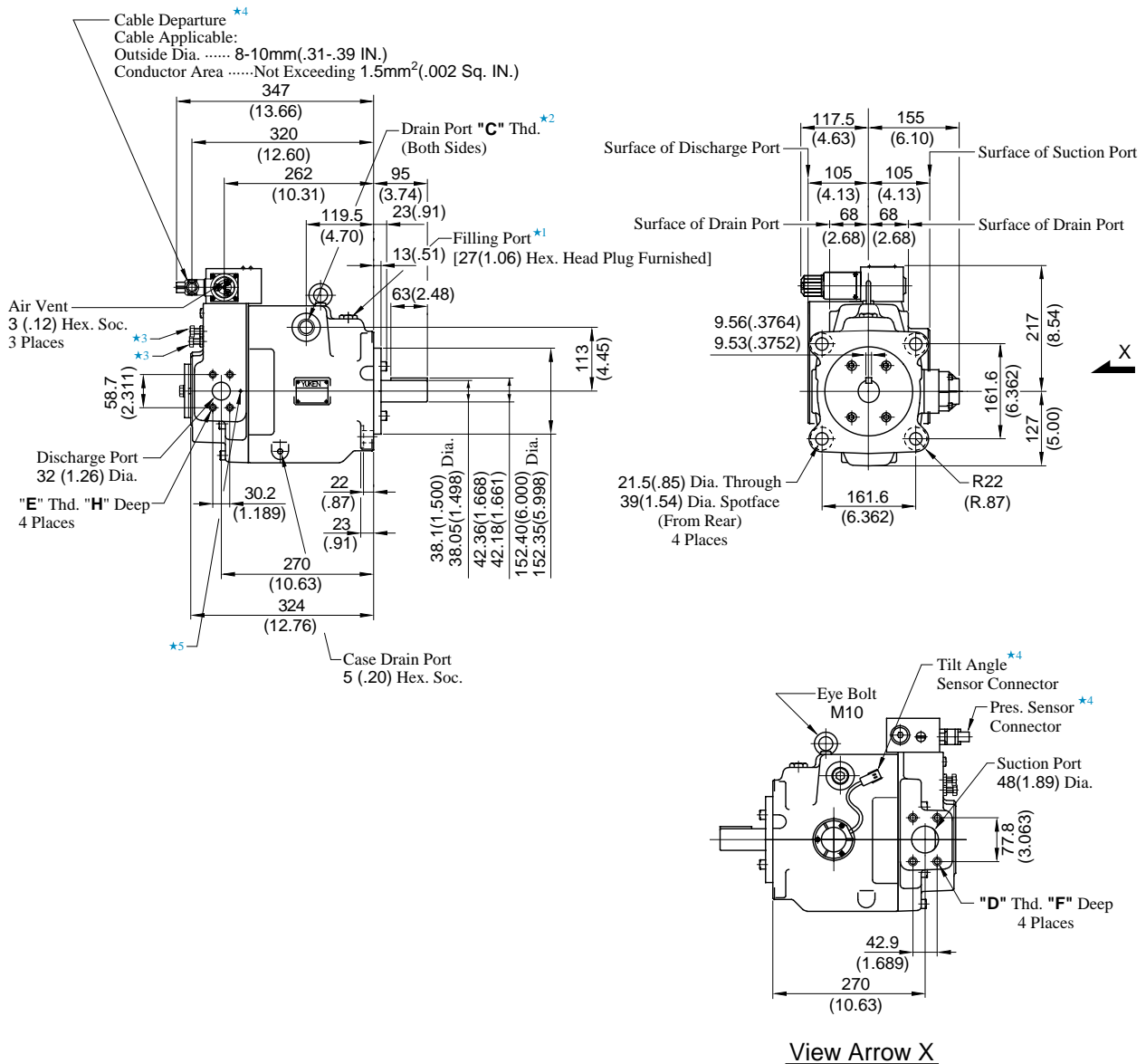

- ★1. Install the pump so that the "Filling Port" is at the top.
- ★2. Use either port of two drain ports at your option. Keep the remaining ports plugged. Note that on the European design standard (6080 Design), only the left side, as viewed from the shaft end, of the drain port is machined.
- ★3. Do not touch the screw because it is adjusted at the time of shipment.
- ★4. For cable connection with amplifiers, see page 56.
- ★5. If you do not use the special sequence valve, plug the port (FP-SC-1/32)

Model Numbers	"C" Thd.	"D" Thd.	"E" Thd.	Dimensions mm (IN.)	
				F	H
A90-FR04E**-60-60	Rc 3/4	M12	M10	19 (.75)	19 (.75)
A90-FR04E**-60-6080	3/4 BSP.F				
A90-FR04E**-60-6090	3/4 NPT	1/2-13 UNC	7/16-14 UNC	21 (.83)	20 (.79)

DIMENSIONS IN  
MILLIMETRES (INCHES)

#### ● Foot Mounting Type

Mounting bracket is common to that of pressure compensator model.  
 Refer to page 22 for the dimensions of mounting bracket.

### Installation Drawing

Flange Mtg. : A145-FR04E\*\*-60-60/6080/6090

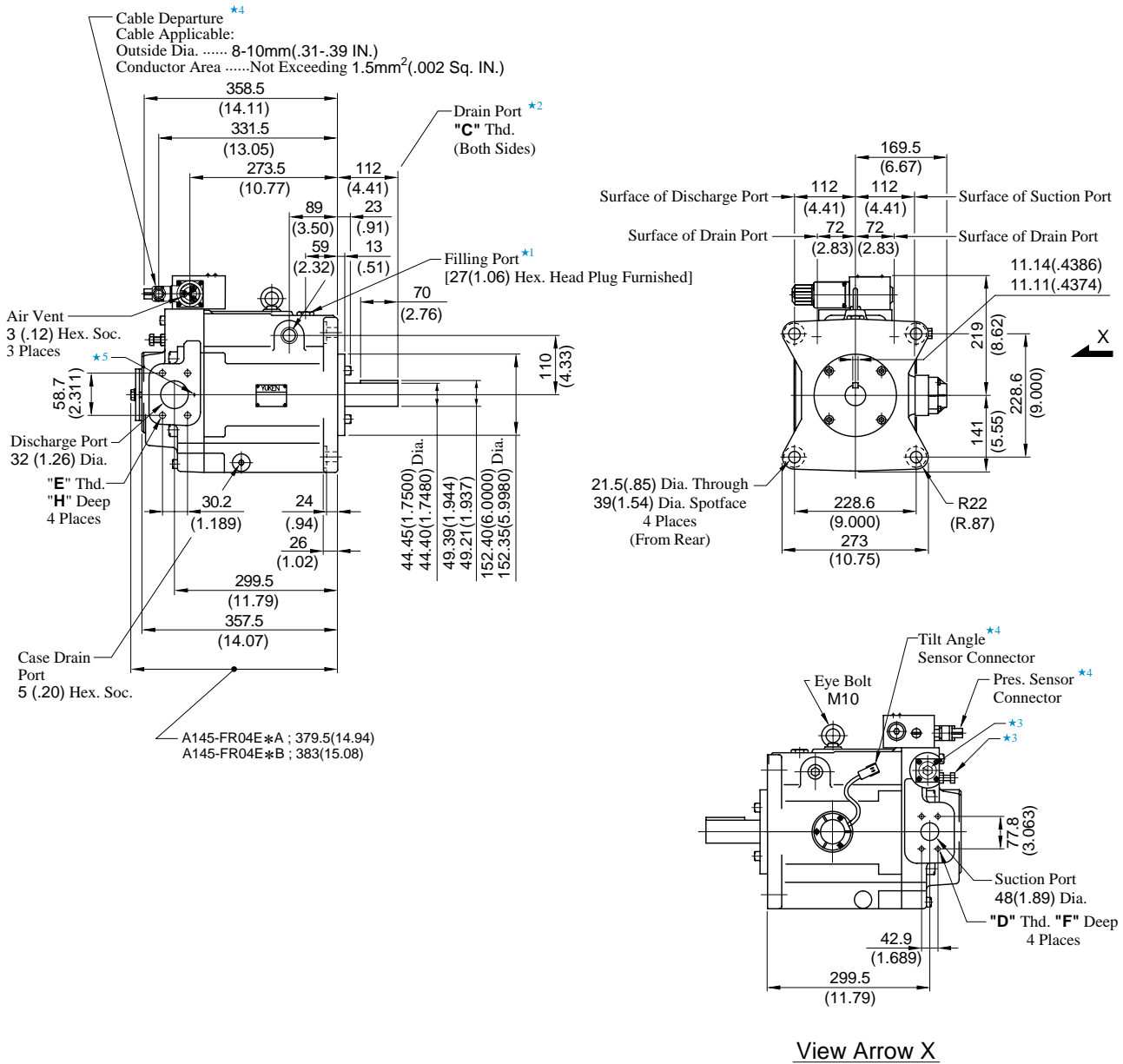

- ★ 1. Install the pump so that the "Filling Port" is at the top.
- ★ 2. Use either port of two drain ports at your option. Keep the remaining port plugged. Note that on the European design standard (6080 Design), only the left side, as viewed from the shaft end, of the drain port is machined.
- ★ 3. Do not touch the screw because it is adjusted at the time of shipment.
- ★ 4. For cable connection with amplifiers, see page 56.
- ★ 5. If you do not use the special sequence valve, plug the port (FP-SC-1/32)

Model Numbers	"C" Thd.	"D" Thd.	"E" Thd.	Dimensions mm (IN.)	
				F	H
A145-FR04E**-60-60	Rc 3/4	M12	M10	19 (.75)	19 (.75)
A145-FR04E**-60-6080	3/4 BSP.F				
A145-FR04E**-60-6090	3/4 NPT	1/2-13 UNC	7/16-14 UNC	21 (.83)	20 (.79)

DIMENSIONS IN  
MILLIMETRES (INCHES)

#### ● Foot Mounting Type

Mounting bracket is common to that of pressure compensator model.  
Refer to page 23 for the dimensions of mounting bracket.

### Cable connection between pump and amplifier

#### ■ Cable connection between pump and amplifier

The cable connections between the proportional pilot valve and the sensor of the pump and the attached amplifier (SK1106) are shown below.

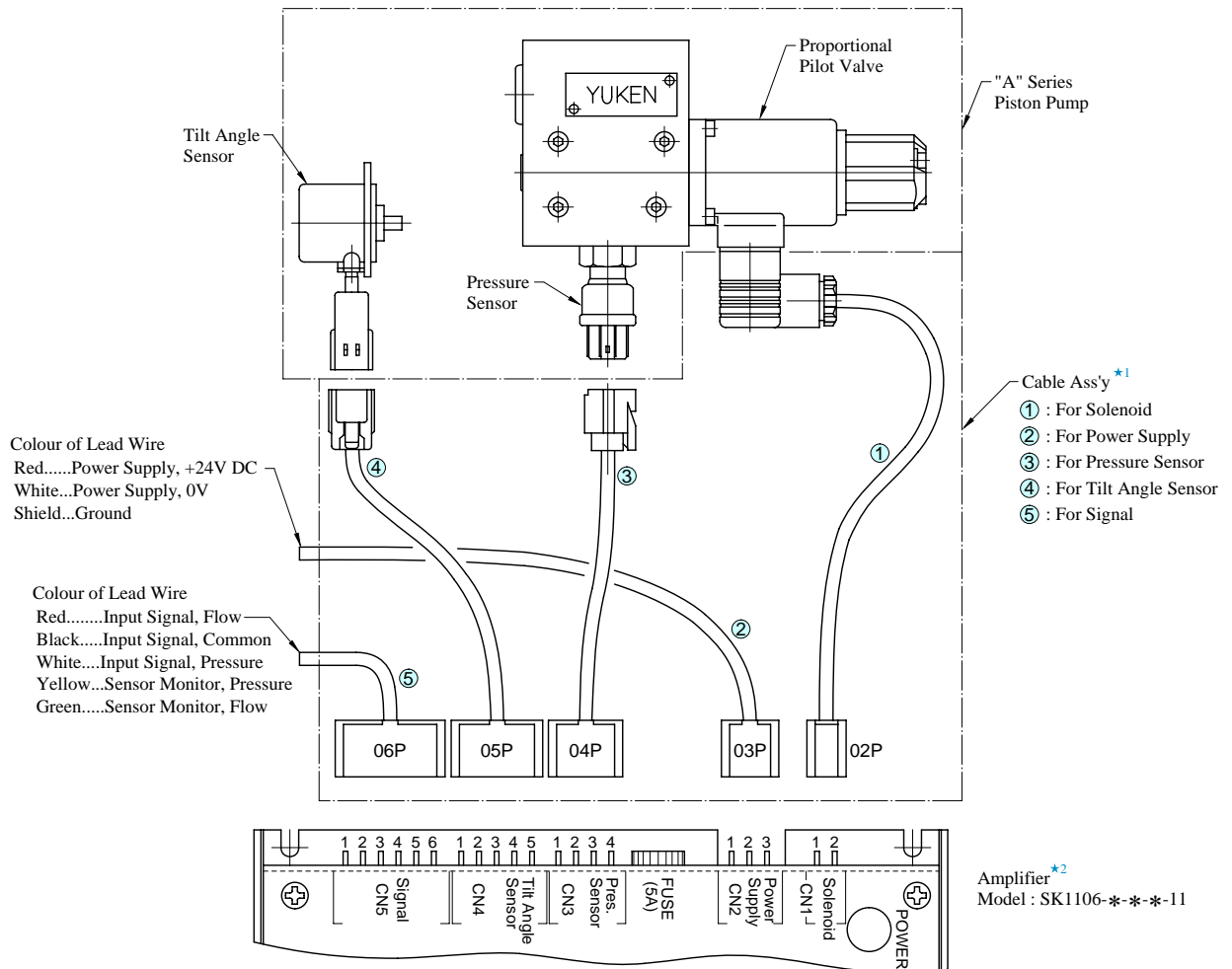

★ 1. Cable assemblies are available. When ordering, specify the cable ass'y model numbers from the table below.

Name of Cable Ass'y	Cable Ass'y Model Numbers		
	Approx. Length of Cable mm(ft.)		
	2000 (6.6)	5000 (16.4)	10000 (32.8)
① For Solenoid	SK1112-S-2-10	SK1112-S-5-10	SK1112-S-10-10
② For Power Supply	SK1112-V-2-10	SK1112-V-5-10	SK1112-V-10-10
③ For Pressure Sensor	SK1112-P-2-10	SK1112-P-5-10	SK1112-P-10-10
④ For Tilt Angle Sensor	SK1112-Q-2-10	SK1112-Q-5-10	SK1112-Q-10-10
⑤ For Signal	SK1112-C-2-10	SK1112-C-5-10	SK1112-C-10-10

★ 2. For the details of amplifier, see the following page.

#### Specifications

Description	Model No.	SK1106-**-**-10
Applicable Coil Resistance		10 Ω
Input Impedance		10 kΩ
Power Supply		24 V DC (21 - 28 V Included Ripple)
Power Input (Max.)		30 W
Input Signal		Max. Flow/5V, Specified Pres./5V
Output Signal for Sensor Monitor		5V/Max. Flow, 5V/Specified Pres.
Ambient Temperature		0 - 50 °C (32 - 122 °F)
Approx. Mass		450 g (1.0 lbs.)

#### List of Amplifier Model No.

Pump Model Numbers	Amplifier Model Numbers
A16-★R04E-06-42★	SK1106-★-16-06-10
A22-★R04E-11-42★	SK1106-★-22-11-10
A37-★R04E-01-42★	SK1106-★-37-01-10
A56-★R04E-02-42★	SK1106-★-56-02-10
A70-★R04E-★-60-60★	SK1106-★-70-60-10
A90-★R04E-★-60-60★	SK1106-★-91-60-10
A145-★R04E-★-60-60★	SK1106-★-145-60-10

Note: Fill control pressure (at input signal is 5 V) in section marked ★.

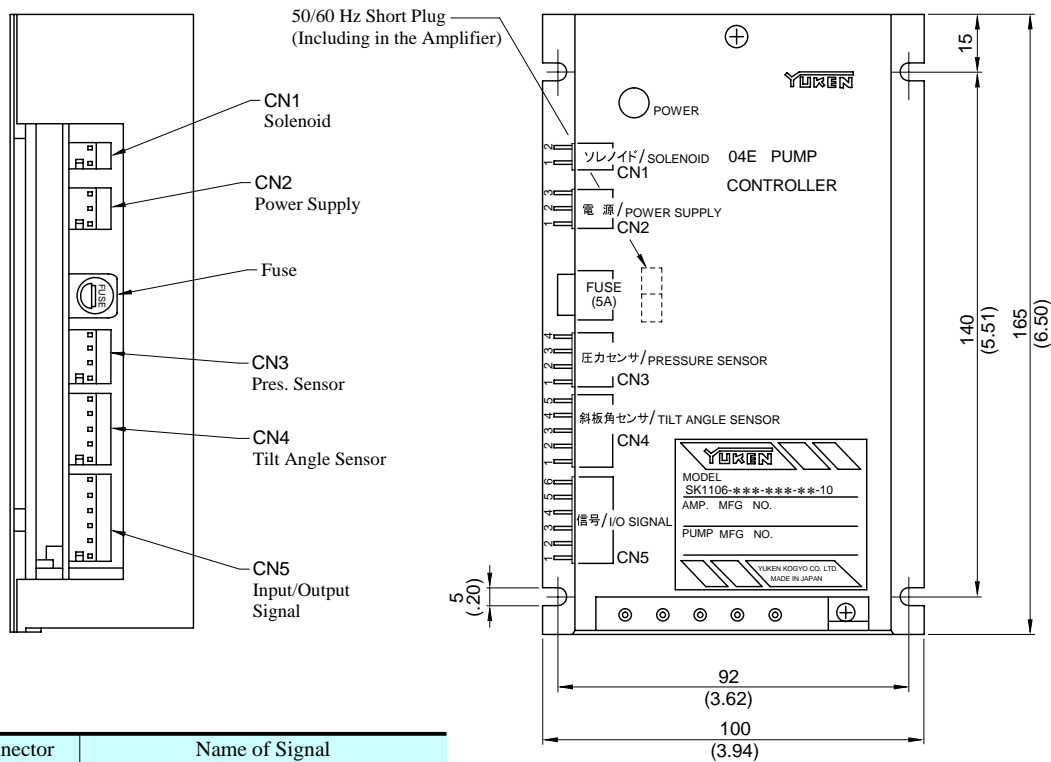

Connector	Name of Signal	
CN1 Solenoid	1	Output to pilot valve solenoid
	2	
CN2 Power Supply	1	0 [V] (0V)
	2	+24 [V] (24V)
	3	0 [V]
CN3 Pres. Sensor	1	+5 [V] Power Supply for Sensor
	2	0 [V]
	3	Input Signal - Sensor
	4	0 [V]
CN4 Tilt Angle Sensor	1	+8 [V] Power Supply for Sensor
	2	0 [V]
	3	Input Signal - Sensor
	4	0 [V]
	5	—
CN5 Input/Output Signal	1	Input Signal - Flow (Qin)
	2	Input Signal - Common (COM)
	3	Input Signal - Pres. (Pin)
	4	Output Signal - Sensor Monitor P (SMP)
	5	Output Signal - Sensor Monitor Q (SMQ)
	6	0 [V]

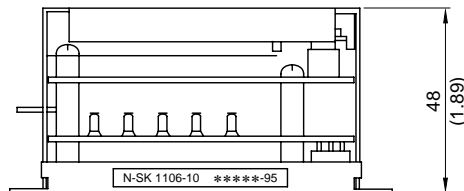

DIMENSIONS IN MILLIMETRES (INCHES)

**Specifications**

Graphic Symbol

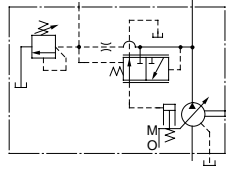

Performance Characteristics

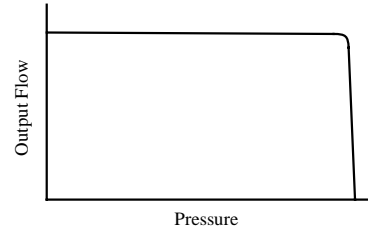

**Specifications**

Model Numbers	Geometric Displacement cm <sup>3</sup> /rev (cu. in. /rev)	Minimum Adj. Flow cm <sup>3</sup> /rev (cu. in. /rev)	Operating Pres. MPa (PSI)		Minimum Adj. Pres. MPa (PSI)	Shaft Speed Range r/min		Approx. Mass kg (lbs.)	
			Rated <sup>*2</sup>	Intermittent <sup>*1</sup>		Max.	Min.	Flange Mtg.	Foot Mtg.
A10-FR07-12*	10.0 (.610)	2 (.122)	16 (2320)	21 (3050)	2.0 (290)	1800	600	8.5 (18.7)	10.7 (23.6)
A16-*-R-07-*-K-32*	15.8 (.964)	4 (.244)	16 (2320)	21 (3050)	1.2 (175)	1800	600	21 (46.3)	23.2 (51.2)
A22-*-R-07-*-K-32*	22.2 (1.355)	6 (.366)	16 (2320)	16 (2320)	1.2 (175)	1800	600	21 (46.3)	23.2 (51.2)
A37-*-R-07-*-K-32*	36.9 (2.25)	10 (.610)	16 (2320)	21 (3050)	1.2 (175)	1800	600	29 (63.9)	33.3 (73.4)
A56-*-R-07-*-K-32*	56.2 (3.43)	12 (.732)	16 (2320)	21 (3050)	1.2 (175)	1800	600	36 (79.4)	40.3 (88.9)
A70-*R07S-60*	70.0 (4.27)	30 (1.83)	25 (3630)	25 (3630)	2 (290)	1800	600	60.3 (133)	72.3 (159)
A90-*R07S-60*	91.0 (5.55)	56 (3.42)	25 (3630)	25 (3630)	2 (290)	1800	600	77.5 (171)	98 (216)
A145-*R07S-60*	145 (8.85)	83 (5.06)	25 (3630)	25 (3630)	2 (290)	1800	600	94 (207)	119 (262)

- ★1. Whenever setting pressure, make sure the full cut-off pressure never exceeds the maximum intermittent pressure.
- ★2. When operating the pump exceeding the rated pressure, operating conditions are restricted.  
Refer to page 6 for the details.

**Model Number Designation**

■ **Model Number Designation**

<b>A16</b>	<b>-F</b>	<b>-R</b>	<b>-07</b>	<b>-S</b>	<b>-K</b>	<b>-32</b>	<b>*</b>
Series Number	Mounting	Direction of Rotation	Control Type	Port Position	Shaft Extension	Design Number	Design Std.
<b>A16</b> (15.8 cm <sup>3</sup> /rev)	<b>F:</b> Flange Mtg.	(Viewed from) Shaft End )  <b>R:</b> Clockwise <sup>★1</sup> (Normal)	<b>07:</b> Pilot Pressure Control Type Pressure Compensator	<b>None:</b> Axial Port <sup>★2</sup>  <b>S:</b> Side Port	<b>K:</b> Keyed Shaft	<b>32</b>	Refer to <sup>★4</sup>
<b>A22</b> (22.2 cm <sup>3</sup> /rev)						<b>32</b>	
<b>A37</b> (36.9 cm <sup>3</sup> /rev)	<b>L:</b> Foot Mtg.	<b>32</b>					
<b>A56</b> (56.2 cm <sup>3</sup> /rev)		<b>32</b>					

<b>A70</b>	<b>-F</b>	<b>R</b>	<b>07</b>	<b>S</b>	<b>-60</b>	<b>*</b>
Series Number	Mounting	Direction of Rotation	Control Type	Port Position	Design Number	Design Std.
<b>A10</b> (10.0 cm <sup>3</sup> /rev)	<b>F:</b> Flange Mtg. <sup>★3</sup>	(Viewed from) Shaft End )  <b>R:</b> Clockwise <sup>★1</sup> (Normal)	<b>07:</b> Pilot Pressure Control Type Pressure Compensator	—	<b>12</b>	Refer to <sup>★4</sup>
<b>A70</b> (70 cm <sup>3</sup> /rev)	<b>F:</b> Flange Mtg.  <b>L:</b> Foot Mtg.			<b>S:</b> Side Port	<b>60</b>	
<b>A90</b> (91.0 cm <sup>3</sup> /rev)		<b>60</b>				
<b>A145</b> (145 cm <sup>3</sup> /rev)		<b>60</b>				

- ★1. Available to supply pump with anti-clockwise rotation. Consult Yuken for details.
- ★2. The axial port is not available to the N.American Design Standard of A37 and A56.
- ★3. When A10 pump is used as the foot Mtg., order the Mtg. Bracket kit shown below separately. Refer to page 17 for dimensions of the Mtg. bracket.
- ★4. Design Standards: None ..... Japanese Standard "JIS"  
 80 ..... European Design Standard  
 90 ..... N. American Design Standard

Mtg. Bracket Kit Numbers	Approx. Mass kg (lbs.)
LP-1A-10	2.2 (4.9)

Note: The mounting bracket kit consists of a mounting bracket, 2 hex. bolts and 2 plain washer.

■ **Performance Characteristics**

For performance characteristics, refer to models of pressure compensator type on page 10 to 16.

■ **Pipe Flange Kit**

For pipe flange, refer to form of pressure compensator type on page 7.

Flange Mtg. : A10-FR07-12/1280/1290

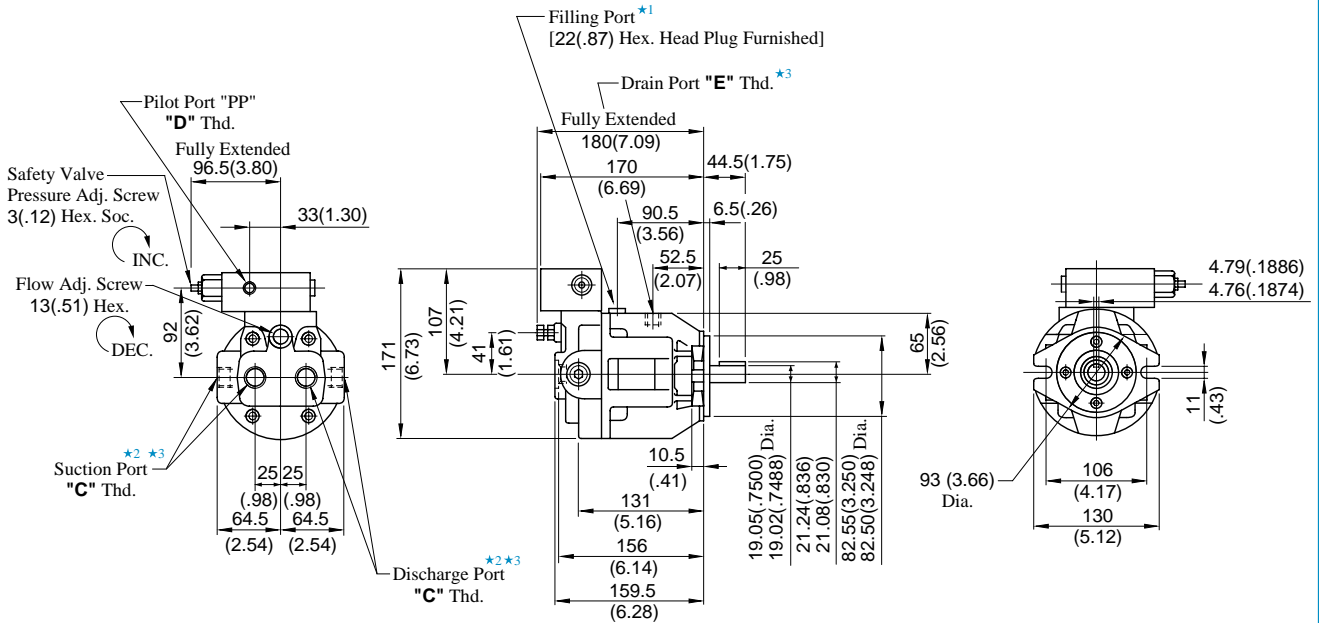

- ★ 1. Install the pump so that the "Filling Port" is at the top.
- ★ 2. Use either port of two suction and outlet ports at your option. Keep the remaining ports plugged.

- ★ 3. As the tightening torques of suction, discharge and drain port fittings, conform to the below.

Model Numbers	"C" Thd.	"D" Thd.	"E" Thd.
A10-FR07-12	Rc 1/2	Rc 1/4	Rc 3/8
A10-FR07-1280	1/2 BSP.F	1/4 BSP.Tr	3/8 BSP.F
A10-FR07-1290	1/2 NPT	1/4 NPT	3/8 NPT

Port	Tightening Torque
Suction Port	65 - 75 Nm
Discharge Port	(575 - 664 IN. lbs)
Drain Port	40 - 50 Nm
	(354 - 443 IN. lbs)

DIMENSIONS IN  
MILLIMETRES (INCHES)

#### ● Foot Mounting Type

Mounting bracket is common to that of pressure compensator model.  
Refer to page 17 for the dimensions of mounting bracket.

### Installation Drawing

#### Axial Port Type

Flange Mtg. : A16-F-R-07-K-32/3280/3290  
A22-F-R-07-K-32/3280/3290

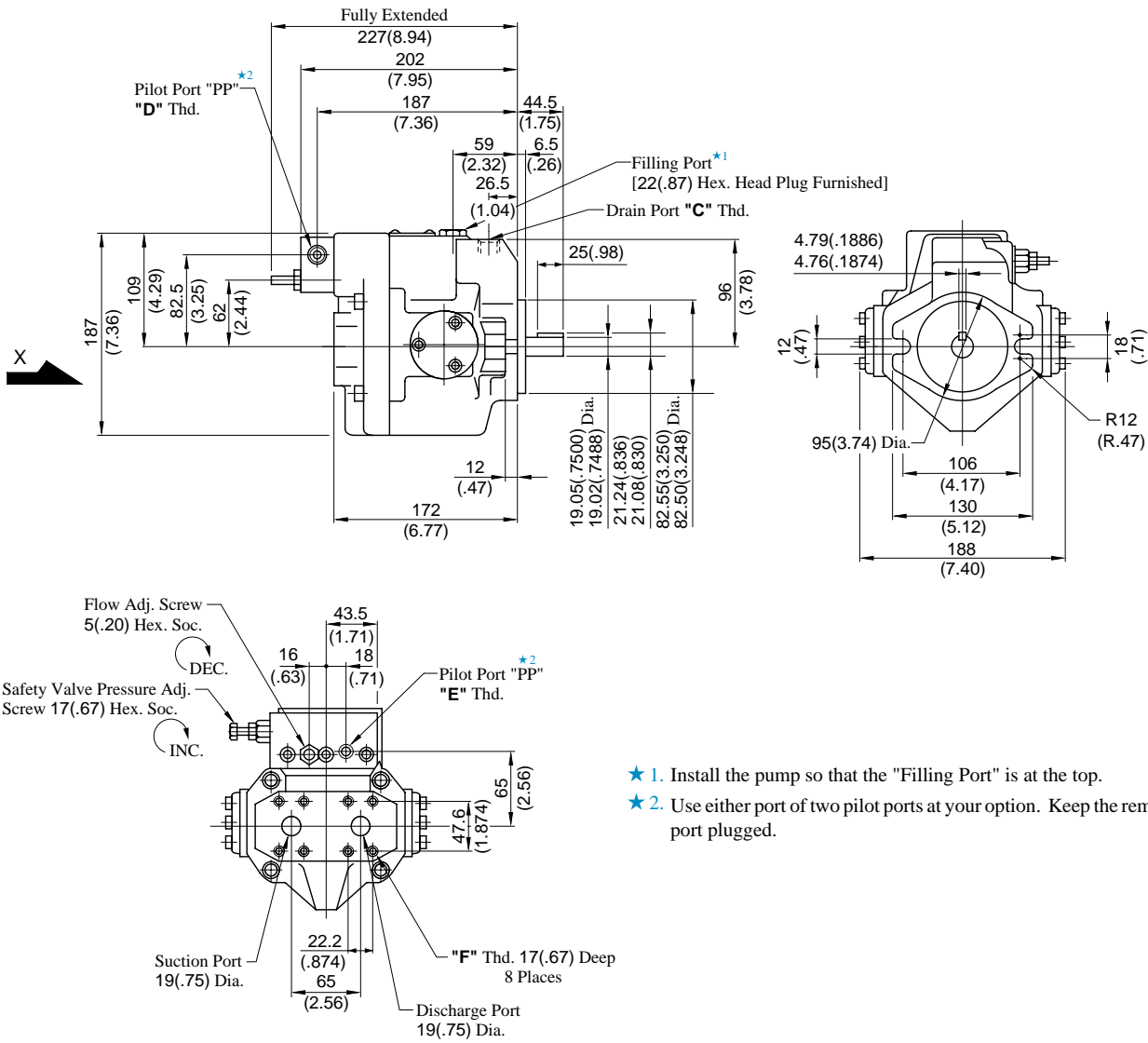

View Arrow X

- ★ 1. Install the pump so that the "Filling Port" is at the top.
- ★ 2. Use either port of two pilot ports at your option. Keep the remaining port plugged.

Model Numbers	"C" Thd.	"D" Thd.	"E" Thd.	"F" Thd.
A16/A22-F-R-07-K-32	Rc 3/8	Rc 3/8	Rc 1/4	M10
A16/A22-F-R-07-K-3280	3/8 BSP. F	3/8 BSP. F	1/4 BSP. Tr	
A16/A22-F-R-07-K-3290	3/8 NPT	3/8 NPT	1/4 NPT	3/8-16 UNC

DIMENSIONS IN  
MILLIMETRES (INCHES)

#### ● Side Port Type

Port mounting dimensions are the same as those of pressure compensator model. Refer to page 18 for port mounting dimensions.

#### ● Foot Mounting Type

Mounting bracket is common to that of pressure compensator model. Refer to page 18 for the dimensions of mounting bracket.



#### Side Port Type

Flange Mtg. : A37-F-R-07-S-K-32/3280/3290

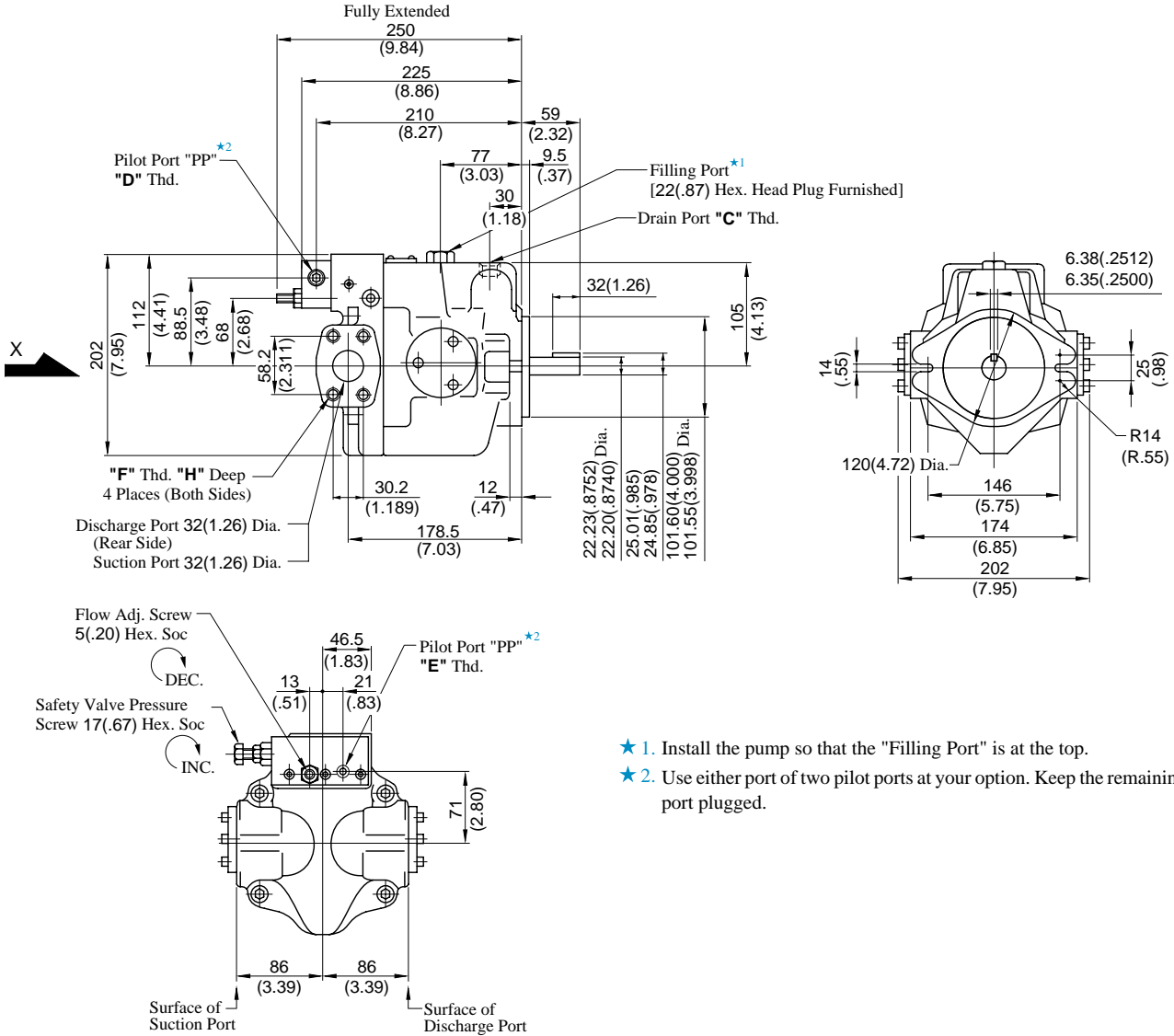

- ★ 1. Install the pump so that the "Filling Port" is at the top.
- ★ 2. Use either port of two pilot ports at your option. Keep the remaining port plugged.

View Arrow X

Model Numbers	"C" Thd.	"D" Thd.	"E" Thd.	"F" Thd.	"H" mm (IN.)
A37-F-R-07-S-K-32	Rc 1/2	Rc 3/8	Rc 1/4	M10	19 (.75)
A37-F-R-07-S-K-3280	1/2 BSP.F	3/8 BSP.F	1/4 BSP. Tr		
A37-F-R-07-S-K-3290	1/2 NPT	3/8 NPT	1/4 NPT	7/16-14 UNC	20 (.79)

DIMENSIONS IN  
MILLIMETRES (INCHES)

#### ● Axial Port Type

Port mounting dimensions are the same as those of pressure compensator model. Refer to page 19 for port mounting dimensions.

Note: "Axial Port Type" is not available for N. American Design Standard.

#### ● Foot Mounting Type

Mounting bracket is common to that of pressure compensator model. Refer to page 19 for the dimensions of mounting bracket.

### Installation Drawing

#### Side Port Type

Flange Mtg. : A56-F-R-07-S-K-32/3280/3290

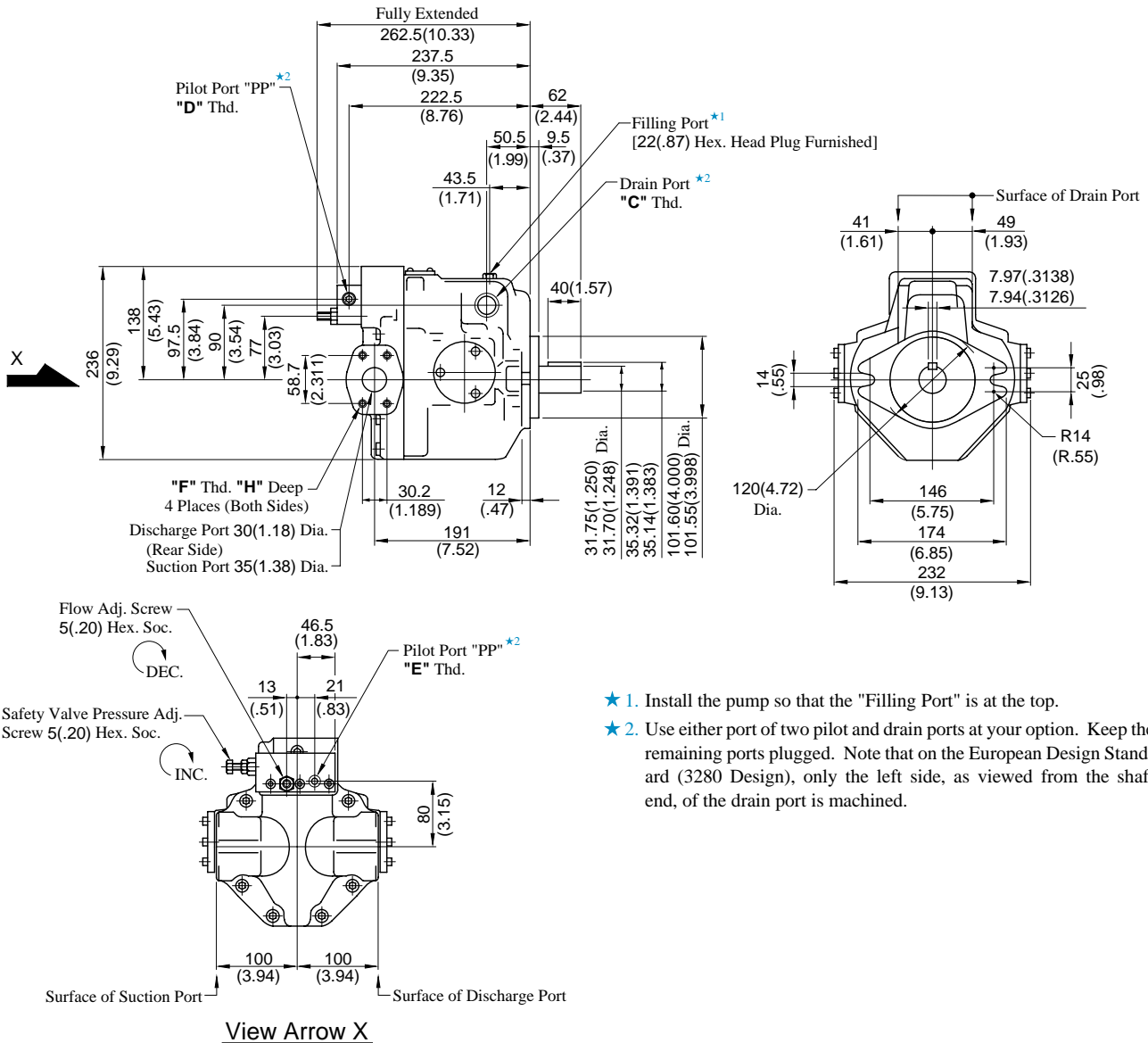

- ★ 1. Install the pump so that the "Filling Port" is at the top.
- ★ 2. Use either port of two pilot and drain ports at your option. Keep the remaining ports plugged. Note that on the European Design Standard (3280 Design), only the left side, as viewed from the shaft end, of the drain port is machined.

Model Numbers	"C" Thd.	"D" Thd.	"E" Thd.	"F" Thd.	"H" mm (IN.)
A56-F-R-07-S-K-32	Rc 3/4	Rc 3/8	Rc 1/4	M10	19 (.75)
A56-F-R-07-S-K-3280	3/4 BSP.F	3/8 BSP.F	1/4 BSP. Tr		
A56-F-R-07-S-K-3290	3/4 NPT	3/8 NPT	1/4 NPT	7/16-14 UNC	20 (.79)

DIMENSIONS IN  
MILLIMETRES (INCHES)

#### ● Axial Port Type

Port mounting dimensions are the same as those of pressure compensator model. Refer to page 20 for port mounting dimensions.

Note: "Axial Port Type" is not available for N. American Design Standard.

#### ● Foot Mounting Type

Mounting bracket is common to that of pressure compensator model. Refer to page 20 for the dimensions of mounting bracket.

Flange Mtg. : A70-FR07S-60/6080/6090

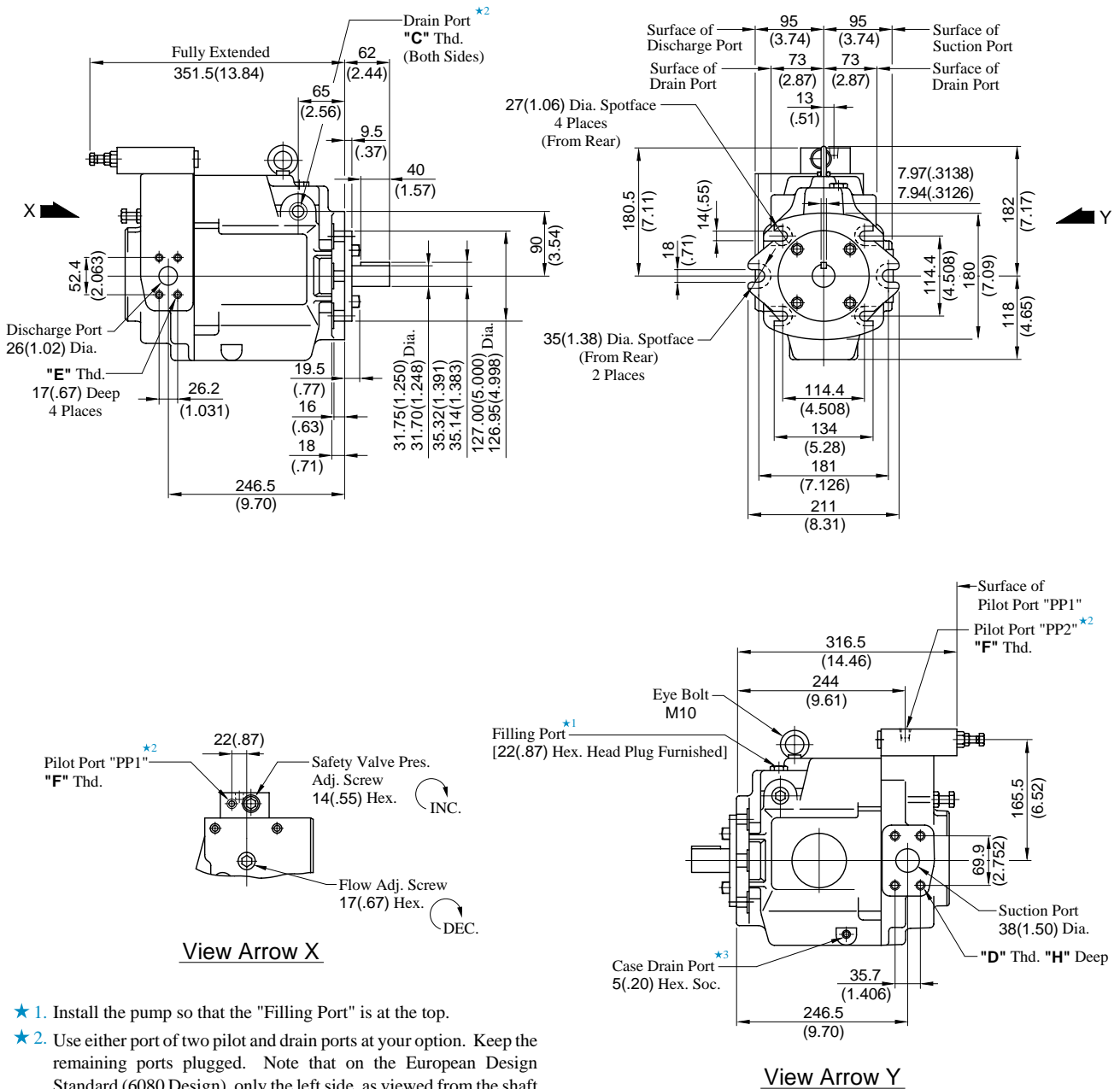

- ★ 1. Install the pump so that the "Filling Port" is at the top.
- ★ 2. Use either port of two pilot and drain ports at your option. Keep the remaining ports plugged. Note that on the European Design Standard (6080 Design), only the left side, as viewed from the shaft end, of the drain port is machined.
- ★ 3. Case drain port is available for use when draining hydraulic fluid from pump casing.

Model Numbers	"C" Thd.	"D" Thd.	"E" Thd.	"F" Thd.	"H" mm (IN.)
A70-FR07S-60	Rc 3/4	M12	M10	Rc 1/4	19 (.75)
A70-FR07S-6080	3/4 BSP.F			1/4 BSP. Tr	
A70-FR07S-6090	3/4 NPT	1/2-13 UNC	3/8-16 UNC	1/4 NPT	21 (.83)

DIMENSIONS IN  
MILLIMETRES (INCHES)

#### ● Foot Mounting Type

Mounting bracket is common to that of pressure compensator model.  
Refer to page 21 for the dimensions of mounting bracket.

### Installation Drawing

Flange Mtg. : A90-FR07S-60/6080/6090

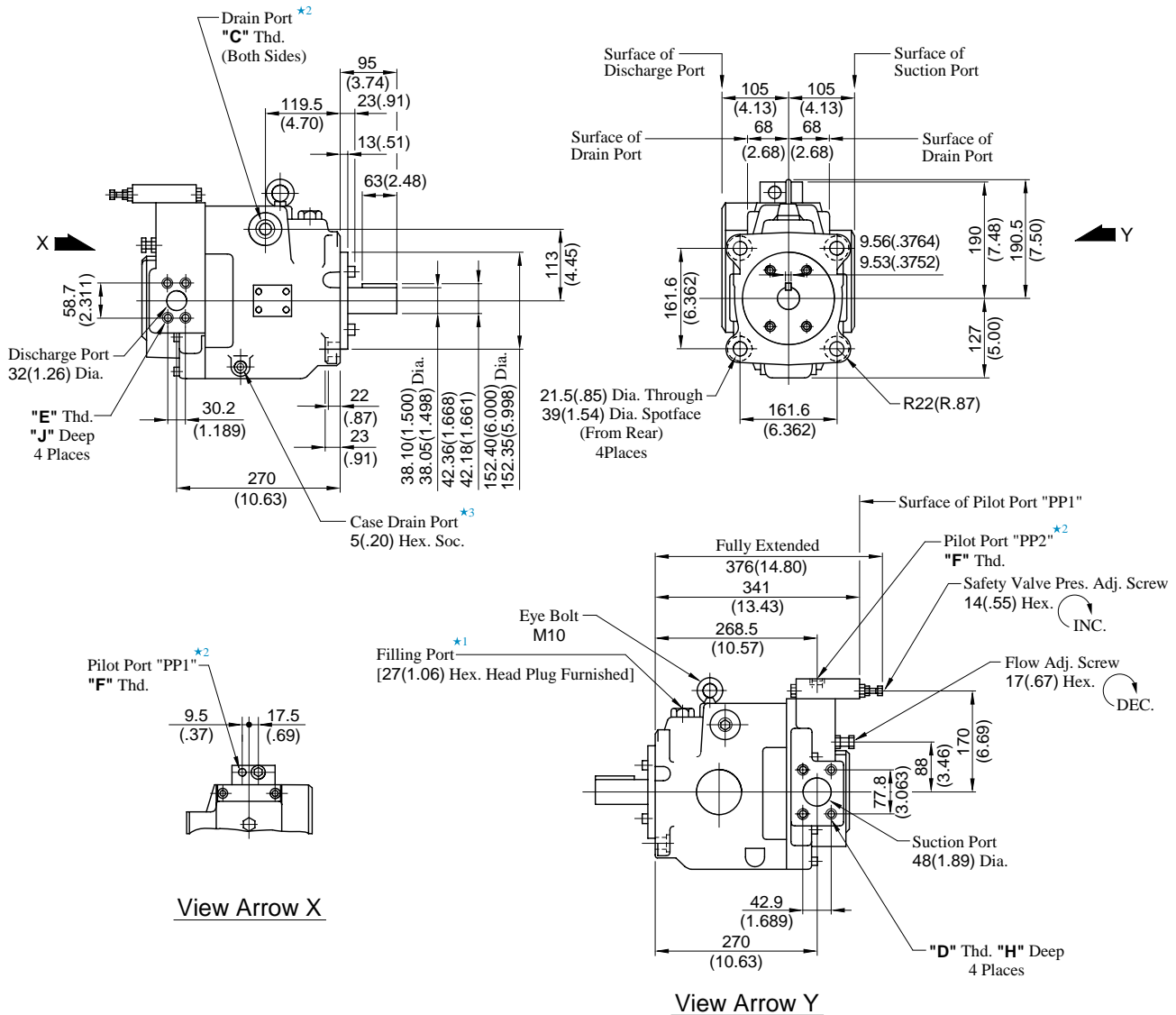

- ★ 1. Install the pump so that the "Filling Port" is at the top.
- ★ 2. Use either port of two pilot and drain ports at your option. Keep the remaining ports plugged. Note that on the European Design Standard (6080 Design), only the left side, as viewed from the shaft end, of the drain port is machined.
- ★ 3. Case drain port is available for use when draining hydraulic fluid from pump casing.

Model Numbers	"C" Thd.	"D" Thd.	"E" Thd.	"F" Thd.	H mm (IN.)	J mm (IN.)
A90-FR07S-60	Rc 3/4	M12	M10	Rc 1/4	19 (.75)	19 (.75)
A90-FR07S-6080	3/4 BSP.F			1/4 BSP. Tr		
A90-FR07S-6090	3/4 NPT	1/2-13 UNC	7/16-14 UNC	1/4 NPT	21 (.83)	20 (.79)

DIMENSIONS IN  
MILLIMETRES (INCHES)

#### ● Foot Mounting Type

Mounting bracket is common to that of pressure compensator model.  
Refer to page 22 for the dimensions of mounting bracket.

Flange Mtg. : A145-FR07S-60/6080/6090

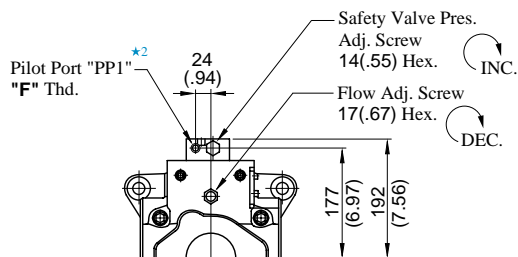
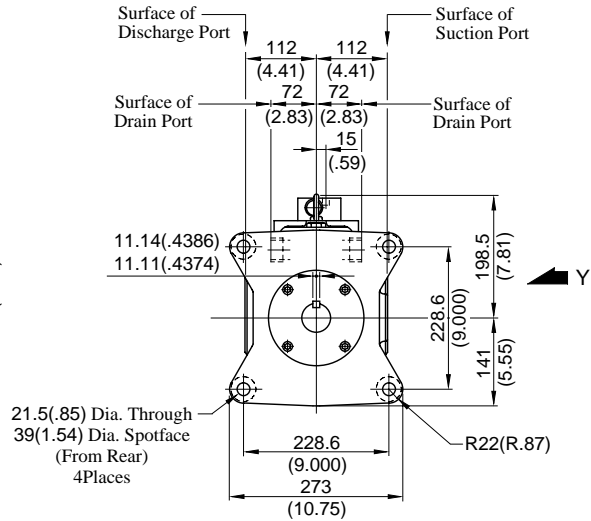
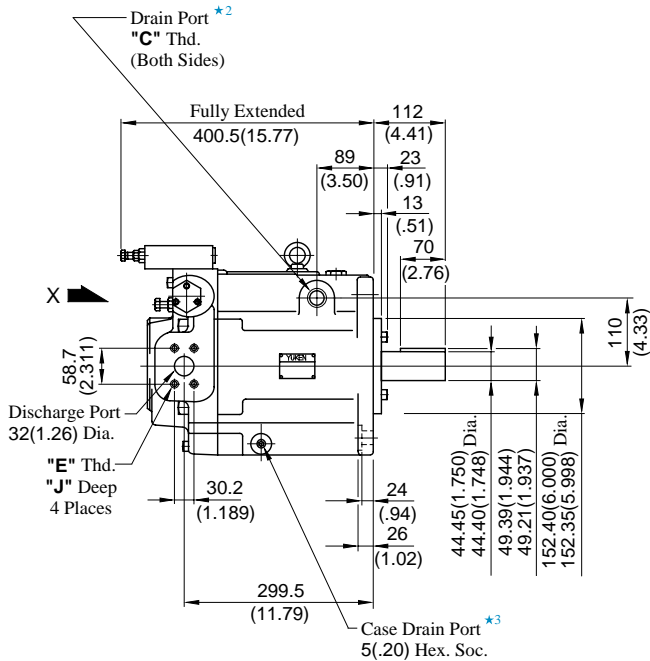

View Arrow X

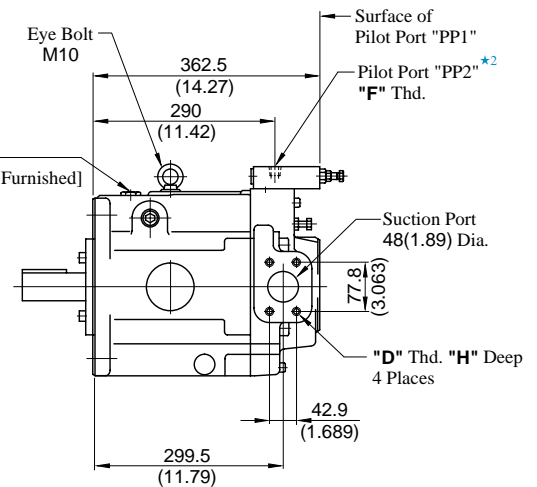

View Arrow Y

- ★ 1. Install the pump so that the "Filling Port" is at the top.
- ★ 2. Use either port of two pilot and drain ports at your option. Keep the remaining ports plugged. Note that on the European Design Standard (6080 Design), only the left side, as viewed from the shaft end, of the drain port is machined.
- ★ 3. Case drain port is available for use when draining hydraulic fluid from pump casing.

Model Numbers	"C" Thd.	"D" Thd.	"E" Thd.	"F" Thd.	H mm (IN.)	J mm (IN.)
A145-FR07S-60	Rc 3/4	M12	M10	Rc 1/4	19 (.75)	19 (.75)
A145-FR07S-6080	3/4 BSP.F			1/4 BSP. Tr		
A145-FR07S-6090	3/4 NPT	1/2-13 UNC	7/16-14 UNC	1/4 NPT	21 (.83)	20 (.79)

DIMENSIONS IN  
MILLIMETRES (INCHES)

#### ● Foot Mounting Type

Mounting bracket is common to that of pressure compensator model.  
Refer to page 23 for the dimensions of mounting bracket.

### Specifications

Graphic Symbol

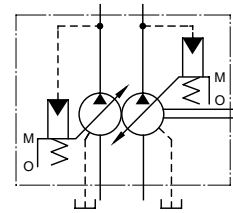
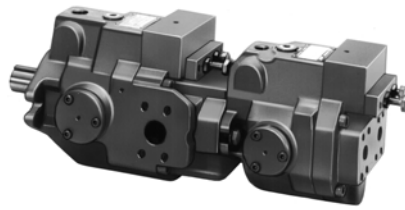

### Specifications

Model Numbers		Geometric Displacement cm <sup>3</sup> /rev (cu.in./rev)	Min. Adj. Flow cm <sup>3</sup> /rev (cu.in./rev)	Operating Pressure MPa (PSI)		Shaft Speed Range r/min		Approx. Mass kg (lbs.)	
				Rated <sup>*2</sup>	Intermittent <sup>*1</sup>	Max.	Min.	Flange Mtg.	Foot Mtg.
A1616- <sup>*3</sup> R01*01**K-32*	Outboard Pump	15.8 (.964)	4 (.244)	16 (2320)	21 (3050)	1800	600	35.5 (98.3)	37.7 (83.1)
	Inboard Pump	15.8 (.964)	4 (.244)	16 (2320)	21 (3050)				
A1622- <sup>*3</sup> R01*01**K-32*	Outboard Pump	15.8 (.964)	4 (.244)	16 (2320)	21 (3050)	1800	600	35.5 (98.3)	37.7 (83.1)
	Inboard Pump	22.2 (1.355)	6 (.366)	16 (2320)	16 (2320)				
A2222- <sup>*3</sup> R01*01**K-32*	Outboard Pump	22.2 (1.355)	6 (.366)	16 (2320)	16 (2320)	1800	600	35.5 (98.3)	37.7 (83.1)
	Inboard Pump	22.2 (1.355)	6 (.366)	16 (2320)	16 (2320)				
A1637- <sup>*3</sup> R01*01**K-32*	Outboard Pump	15.8 (.964)	4 (.244)	16 (2320)	21 (3050)	1800	600	50 (110)	54.3 (120)
	Inboard Pump	36.9 (2.25)	10 (.610)	16 (2320)	21 (3050)				
A2237- <sup>*3</sup> R01*01**K-32*	Outboard Pump	22.2 (1.355)	6 (.366)	16 (2320)	16 (2320)	1800	600	50 (110)	54.3 (120)
	Inboard Pump	36.9 (2.25)	10 (.610)	16 (2320)	21 (3050)				
A1656- <sup>*3</sup> R01*01**K-32*	Outboard Pump	15.8 (.964)	4 (.244)	16 (2320)	21 (3050)	1800	600	54.5 (120)	58.8 (130)
	Inboard Pump	56.2 (3.43)	12 (.732)	16 (2320)	21 (3050)				
A2256- <sup>*3</sup> R01*01**K-32*	Outboard Pump	22.2 (1.355)	6 (.366)	16 (2320)	16 (2320)	1800	600	54.5 (120)	58.8 (130)
	Inboard Pump	56.2 (3.43)	12 (.732)	16 (2320)	21 (3050)				
A1670- <sup>*3</sup> R01*01**-60*	Outboard Pump	15.8 (.964)	4 (.244)	16 (2320)	21 (3050)	1800	600	77.5 (171)	89.5 (197)
	Inboard Pump	70.0 (4.27)	30 (1.831)	25 (3630)	28 (4060)				
A2270- <sup>*3</sup> R01*01**-60*	Outboard Pump	22.2 (1.355)	6 (.366)	16 (2320)	16 (2320)	1800	600	77.5 (171)	89.5 (197)
	Inboard Pump	70.0 (4.27)	30 (1.831)	25 (3630)	28 (4060)				
A3770- <sup>*3</sup> R01*01**-60*	Outboard Pump	36.9 (2.25)	10 (.610)	16 (2320)	21 (3050)	1800	600	86.5 (191)	98.5 (217)
	Inboard Pump	70.0 (4.27)	30 (1.831)	25 (3630)	28 (4060)				
A1690- <sup>*3</sup> R01*01**-60*	Outboard Pump	15.8 (.964)	4 (.244)	16 (2320)	21 (3050)	1800	600	88 (194)	108.5 (239)
	Inboard Pump	91.0 (5.55)	56 (3.42)	25 (3630)	28 (4060)				
A2290- <sup>*3</sup> R01*01**-60*	Outboard Pump	22.2 (1.355)	6 (.366)	16 (2320)	16 (2320)	1800	600	88 (194)	108.5 (239)
	Inboard Pump	91.0 (5.55)	56 (3.42)	25 (3630)	28 (4060)				
A3790- <sup>*3</sup> R01*01**-60*	Outboard Pump	36.9 (2.25)	10 (.610)	16 (2320)	21 (3050)	1800	600	100.5 (222)	121 (267)
	Inboard Pump	91.0 (5.55)	56 (3.42)	25 (3630)	28 (4060)				
A5690- <sup>*3</sup> R01*01**-60*	Outboard Pump	56.2 (3.43)	12 (.732)	16 (2320)	21 (3050)	1800	600	107.5 (237)	128 (282)
	Inboard Pump	91.0 (5.55)	56 (3.42)	25 (3630)	28 (4060)				
A16145- <sup>*3</sup> R01*01**-60*	Outboard Pump	15.8 (.964)	4 (.244)	16 (2320)	21 (3050)	1800	600	109 (240)	134 (295)
	Inboard Pump	145 (8.85)	83 (5.06)	25 (3630)	28 (4060)				
A22145- <sup>*3</sup> R01*01**-60*	Outboard Pump	22.2 (1.355)	6 (.366)	16 (2320)	16 (2320)	1800	600	109 (240)	134 (295)
	Inboard Pump	145 (8.85)	83 (5.06)	25 (3630)	28 (4060)				
A37145- <sup>*3</sup> R01*01**-60*	Outboard Pump	36.9 (2.25)	10 (.610)	16 (2320)	21 (3050)	1800	600	121.5 (268)	146.5 (323)
	Inboard Pump	145 (8.85)	83 (5.06)	25 (3630)	28 (4060)				
A56145- <sup>*3</sup> R01*01**-60*	Outboard Pump	56.2 (3.43)	12 (.732)	16 (2320)	21 (3050)	1800	600	128.5 (283)	153.5 (338)
	Inboard Pump	145 (8.85)	83 (5.06)	25 (3630)	28 (4060)				

- ★ 1. Whenever setting pressure, make sure the full cut-off pressure never exceeds the maximum intermittent pressure.
- ★ 2. When operating the pump exceeding the rated pressure, operating conditions are restricted. Refer to the page 70 for the details.
- ★ 3. The maximum input power of these pumps must be restricted, because of the shaft strength. Refer to the page 70 for the details.

## Model Number Designation

### Model Number Designation

A1637	-F	R	Outboard Pump		Inboard Pump (Driven End)		S	K	-32	*
			01	C	01	C				
Series Number	Mounting	Direction of Rotation	Control Type	Pres. Adj. Range MPa(PSI)	Control Type	Pres. Adj. Range MPa(PSI)	Port Position of Outboard Pump	Shaft Extension	Design Number	Design Std.
<b>A1616</b> (15.8/15.8 cm <sup>3</sup> /rev)		Viewed from Shaft End	01	B: 1.2- 7 (170-1020) C: 1.2-16 (170-2320) H: 1.2-21 (170-3050)	01	B: 1.2- 7 (170-1020) C: 1.2-16 (170-2320) H: 1.2-21 (170-3050)			32	
<b>A1622</b> (15.8/22.2 cm <sup>3</sup> /rev)						B: 1.2- 7 (170-1020) C: 1.2-16 (170-2320)				
<b>A2222</b> (22.2/22.2 cm <sup>3</sup> /rev)						B: 1.2- 7 (170-1020) C: 1.2-16 (170-2320)				
<b>A1637</b> (15.8/36.9 cm <sup>3</sup> /rev)						B: 1.2- 7 (170-1020) C: 1.2-16 (170-2320) H: 1.2-21 (170-3050)				
<b>A2237</b> (22.2/36.9 cm <sup>3</sup> /rev)						B: 1.2- 7 (170-1020) C: 1.2-16 (170-2320)				
<b>A1656</b> (15.8/56.2 cm <sup>3</sup> /rev)						B: 1.2- 7 (170-1020) C: 1.2-16 (170-2320) H: 1.2-21 (170-3050)				
<b>A2256</b> (22.2/56.2 cm <sup>3</sup> /rev)						B: 1.2- 7 (170-1020) C: 1.2-16 (170-2320)				
<b>A1670</b> (15.8/70.0 cm <sup>3</sup> /rev)						B: 1.2- 7 (170-1020) C: 1.2-16 (170-2320) H: 1.2-21 (170-3050)				
<b>A2270</b> (22.2/70.0 cm <sup>3</sup> /rev)						B: 1.2- 7 (170-1020) C: 1.2-16 (170-2320)				
<b>A3770</b> (36.9/70.0 cm <sup>3</sup> /rev)						B: 1.2- 7 (170-1020) C: 1.2-16 (170-2320) H: 1.2-21 (170-3050)				
<b>A1690</b> (15.8/91.0 cm <sup>3</sup> /rev)						B: 1.2- 7 (170-1020) C: 1.2-16 (170-2320)				
<b>A2290</b> (22.2/91.0 cm <sup>3</sup> /rev)						B: 1.2- 7 (170-1020) C: 1.2-16 (170-2320)				
<b>A3790</b> (36.9/91.0 cm <sup>3</sup> /rev)						B: 1.2- 7 (170-1020) C: 1.2-16 (170-2320) H: 1.2-21 (170-3050)				
<b>A5690</b> (56.2/91.0 cm <sup>3</sup> /rev)						B: 1.2- 7 (170-1020) C: 1.2-16 (170-2320) H: 1.2-21 (170-3050)				
<b>A16145</b> (15.8/145 cm <sup>3</sup> /rev)	B: 1.2- 7 (170-1020) C: 1.2-16 (170-2320)									
<b>A22145</b> (22.2/145 cm <sup>3</sup> /rev)	B: 1.2- 7 (170-1020) C: 1.2-16 (170-2320)									
<b>A37145</b> (36.9/145 cm <sup>3</sup> /rev)	B: 1.2- 7 (170-1020) C: 1.2-16 (170-2320) H: 1.2-21 (170-3050)									
<b>A56145</b> (56.2/145 cm <sup>3</sup> /rev)	B: 1.2- 7 (170-1020) C: 1.2-16 (170-2320) H: 1.2-21 (170-3050)									

★1. Available to supply pump with anti-clockwise rotation. Consult Yuken for details. ★2. "Axial Port Type" is not available for N. American Design Standard of A3770, A3790, A37145, A5690 and A56145 types. ★3. Design Standards: None ..... Japanese Standard "JIS" 80 ..... European Design Standard 90 ..... N. American Design Standard

### Pipe Flange Kits

#### ■ Pipe Flange Kits

Pipe flange kits are available. When ordering, specify the kit number from the table below.

Pump Model Nummers	Name of Port	Pipe Flange Kit Numbers						
		Threaded Connection			Socket Welding <sup>*</sup>		Butt Welding	
		Japanese Std. "JIS"	European Design Std.	N. American Design Std.	Japanese Std. "JIS" & European Design Std.	N. American Design Std.	Japanese Std. "JIS" & European Design Std.	N. American Design Std.
A1616 A1622 A2222	Suction & Discharge, Outboard Pump	F5-06-A-10	F5-06-A-1080	F5-06-A-1090	F5-06-B-10	F5-06-B-1090	F5-06-C-10	F5-06-C-1090
	Suction & Discharge, Inboard Pump							
A1637 A2237	Suction & Discharge, Outboard Pump	F5-06-A-10	F5-06-A-1080	F5-06-A-1090	F5-06-B-10	F5-06-B-1090	F5-06-C-10	F5-06-C-1090
	Suction & Discharge, Inboard Pump	F5-10-A-10	F5-10-A-1080	F5-10-A-1090	F5-10-B-10	F5-10-B-1090	F5-10-C-10	F5-10-C-1090
A1656 A2256	Suction & Discharge, Outboard Pump	F5-06-A-10	F5-06-A-1080	F5-06-A-1090	F5-06-B-10	F5-06-B-1090	F5-06-C-10	F5-06-C-1090
	Suction & Discharge, Inboard Pump	F5-10-A-10	F5-10-A-1080	F5-10-A-1090	F5-10-B-10	F5-10-B-1090	F5-10-C-10	F5-10-C-1090
A1670 A2270	Suction & Discharge, Outboard Pump	F5-06-A-10	F5-06-A-1080	F5-06-A-1090	F5-06-B-10	F5-06-B-1090	F5-06-C-10	F5-06-C-1090
	Suction, Inboard Pump	F5-12-A-10	F5-12-A-1080	F5-12-A-1090	F5-12-B-10	F5-12-B-1090	F5-12-C-10	F5-12-C-1090
	Discharge, Inboard Pump	F5-08-A-10	F5-08-A-1080	F5-08-A-1090	F5-08-B-10	F5-08-B-1090	F5-08-C-10	F5-08-C-1090
A3770	Suction & Discharge, Outboard Pump	F5-10-A-10	F5-10-A-1080	F5-10-A-1090	F5-10-B-10	F5-10-B-1090	F5-10-C-10	F5-10-C-1090
	Suction, Inboard Pump	F5-12-A-10	F5-12-A-1080	F5-12-A-1090	F5-12-B-10	F5-12-B-1090	F5-12-C-10	F5-12-C-1090
	Discharge, Inboard Pump	F5-08-A-10	F5-08-A-1080	F5-08-A-1090	F5-08-B-10	F5-08-B-1090	F5-08-C-10	F5-08-C-1090
A1690 A2290	Suction & Discharge, Outboard Pump	F5-06-A-10	F5-06-A-1080	F5-06-A-1090	F5-06-B-10	F5-06-B-1090	F5-06-C-10	F5-06-C-1090
	Suction, Inboard Pump	F5-16-A-10	F5-16-A-1080	F5-16-A-1090	F5-16-B-10	F5-16-B-1090	F5-16-C-10	F5-16-C-1090
	Discharge, Inboard Pump	F5-10-A-10	F5-10-A-1080	F5-10-A-1090	F5-10-B-10	F5-10-B-1090	F5-10-C-10	F5-10-C-1090
A3790 A5690	Suction & Discharge, Outboard Pump	F5-10-A-10	F5-10-A-1080	F5-10-A-1090	F5-10-B-10	F5-10-B-1090	F5-10-C-10	F5-10-C-1090
	Suction, Inboard Pump	F5-16-A-10	F5-16-A-1080	F5-16-A-1090	F5-16-B-10	F5-16-B-1090	F5-16-C-10	F5-16-C-1090
	Discharge, Inboard Pump	F5-10-A-10	F5-10-A-1080	F5-10-A-1090	F5-10-B-10	F5-10-B-1090	F5-10-C-10	F5-10-C-1090
A16145 A22145	Suction & Discharge, Outboard Pump	F5-06-A-10	F5-06-A-1080	F5-06-A-1090	F5-06-B-10	F5-06-B-1090	F5-06-C-10	F5-06-C-1090
	Suction, Inboard Pump	F5-16-A-10	F5-16-A-1080	F5-16-A-1090	F5-16-B-10	F5-16-B-1090	F5-16-C-10	F5-16-C-1090
	Discharge, Inboard Pump	F5-10-A-10	F5-10-A-1080	F5-10-A-1090	F5-10-B-10	F5-10-B-1090	F5-10-C-10	F5-10-C-1090
A37145 A56145	Suction & Discharge, Outboard Pump	F5-10-A-10	F5-10-A-1080	F5-10-A-1090	F5-10-B-10	F5-10-B-1090	F5-10-C-10	F5-10-C-1090
	Suction, Inboard Pump	F5-16-A-10	F5-16-A-1080	F5-16-A-1090	F5-16-B-10	F5-16-B-1090	F5-16-C-10	F5-16-C-1090
	Discharge, Inboard Pump	F5-10-A-10	F5-10-A-1080	F5-10-A-1090	F5-10-B-10	F5-10-B-1090	F5-10-C-10	F5-10-C-1090

★ In case of using socket welding flanges, there is a case where the operating pressure should be set lower than the normal because of strength of the flanges. Therefore, please pay cautious attention to the operating pressure when the socket welding flanges are used.

- Details of the pipe flange kits are given in the Catalogue No. Pub. EC-3001.



### ■ Instructions

#### ● When using at a higher pressure than the rated pressure

Care should be taken in cases of used at a higher pressure than the rated pressure, because operating terms may be restricted. For example, if used as per maximum illustrated operating conditions, intermittent time at maximum flow is restricted to under 1/5 of one cycle time and under 6 seconds simultaneously. Conditions may vary according to the actual working pressure and delivery (inclination angle of the swash plate). Consult factory or Yuken sales representative for further information.

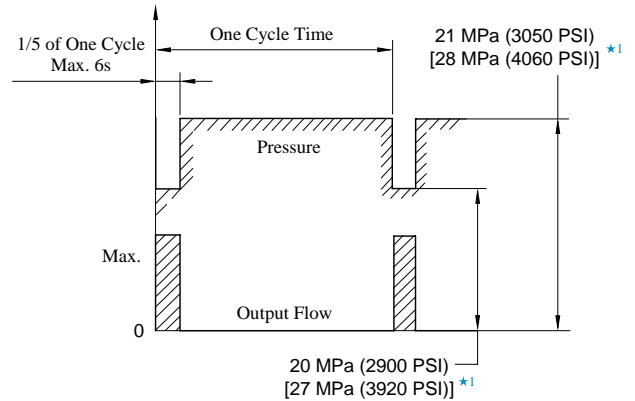

#### ● Allowable Input Power

With the pumps listed in the table below, there is a limit to the sum of the input power of the inboard and outboard pumps because of shaft strength. If both pumps are used for boosting at once, referring to the calculation formulas below, check that the displacements and discharge pressures of both pumps are within the allowable ranges.

★1. Applicable only for the inboard pump of "A\*70", "A\*90" and "A\*145".

$$Q1 \times P1 + Q2 \times P2 \leq L_M$$

Q1 : Displacement (cm<sup>3</sup>/rev)  
P1 : Discharge Pressure (MPa) } Outboard Pump  
Q2 : Displacement (cm<sup>3</sup>/rev)  
P2 : Discharge Pressure (PSI) } Inboard Pump  
L<sub>M</sub>: See the table below

$$Q1 \times P1 + Q2 \times P2 \leq L_P$$

Q1 : Displacement (cu.in./rev)  
P1 : Discharge Pressure (PSI) } Outboard Pump  
Q2 : Displacement (cu.in./rev)  
P2 : Discharge Pressure (PSI) } Inboard Pump  
L<sub>P</sub>: See the table below

Model Numbers	L <sub>M</sub>	L <sub>P</sub>
A1616/A1622/A2222	523	4627
A1637/A2237	900	7963
A3770	2408	21305
A37145/A56145	4739	41930

### ■ Performance Characteristics

Refer to relevant the page for performance characteristics of single pumps excluding noise level characteristics.

Model Numbers	Outboard Pump		Inboard Pump	
	Performance Characteristics	Reference Page	Performance Characteristics	Reference Page
A1616-*R01*01**K-32*	Same as Single Pump "A16"	10	Same as Single Pump "A16"	10
A1622-*R01*01**K-32*	Same as Single Pump "A16"	10	Same as Single Pump "A22"	11
A2222-*R01*01**K-32*	Same as Single Pump "A22"	11		
A1637-*R01*01**K-32*	Same as Single Pump "A16"	10	Same as Single Pump "A37"	12
A2237-*R01*01**K-32*	Same as Single Pump "A22"	11		
A1656-*R01*01**K-32*	Same as Single Pump "A16"	10	Same as Single Pump "A56"	13
A2256-*R01*01**K-32*	Same as Single Pump "A22"	11		
A1670-*R01*01**-60*	Same as Single Pump "A16"	10	Same as Single Pump "A70"	14
A2270-*R01*01**-60*	Same as Single Pump "A22"	11		
A3770-*R01*01**-60*	Same as Single Pump "A37"	12		
A1690-*R01*01**-60*	Same as Single Pump "A16"	10	Same as Single Pump "A90"	15
A2290-*R01*01**-60*	Same as Single Pump "A22"	11		
A3790-*R01*01**-60*	Same as Single Pump "A37"	12		
A5690-*R01*01**-60*	Same as Single Pump "A56"	13	Same as Single Pump "A145"	16
A16145-*R01*01**-60*	Same as Single Pump "A16"	10		
A22145-*R01*01**-60*	Same as Single Pump "A22"	11		
A37145-*R01*01**-60*	Same as Single Pump "A37"	12		
A56145-*R01*01**-60*	Same as Single Pump "A56"	13		

### Installation Drawing

Flange Mtg. : A1616-FR01\*01\*K-32/3280/3290  
 A1622-FR01\*01\*K-32/3280/3290  
 A2222-FR01\*01\*K-32/3280/3290

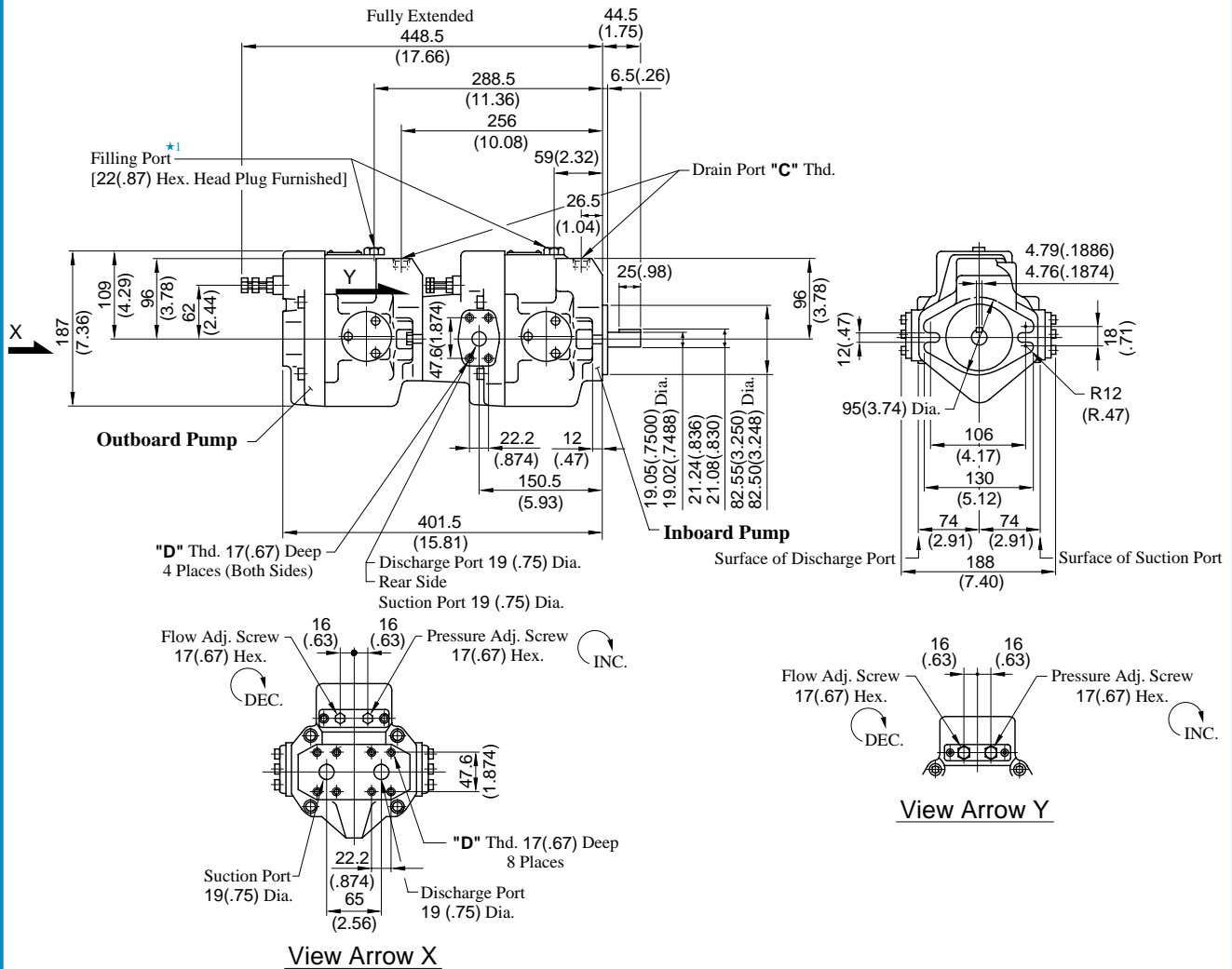

★ 1. Install the pump so that the "Filling Port" is at the top.

Model Numbers	"C" Thd.	"D" Thd.
A1616/A1622/A2222-FR01*01*K-32	Rc 3/8	M10
A1616/A1622/A2222-FR01*01*K-3280	3/8 BSP. F	
A1616/A1622/A2222-FR01*01*K-3290	3/8 NPT	3/8-16 UNC

**DIMENSIONS IN  
MILLIMETRES (INCHES)**

Foot Mtg. : A1616-LR01\*01\*K-32/3280/3290  
 A1622-LR01\*01\*K-32/3280/3290  
 A2222-LR01\*01\*K-32/3280/3290

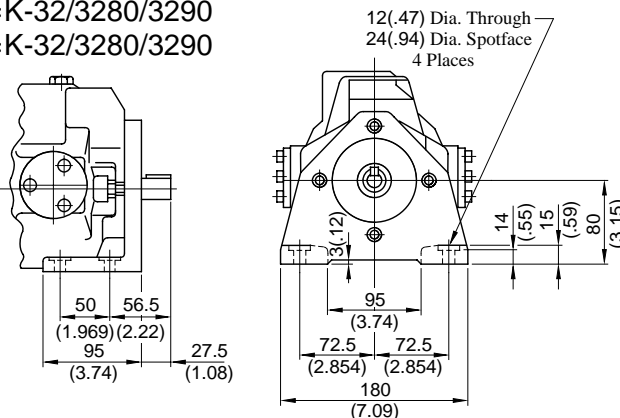

• For other dimensions, refer to "Flange Mtg."

Flange Mtg. : A1637-FR01\*01\*K-32/3280/3290  
A2237-FR01\*01\*K-32/3280/3290

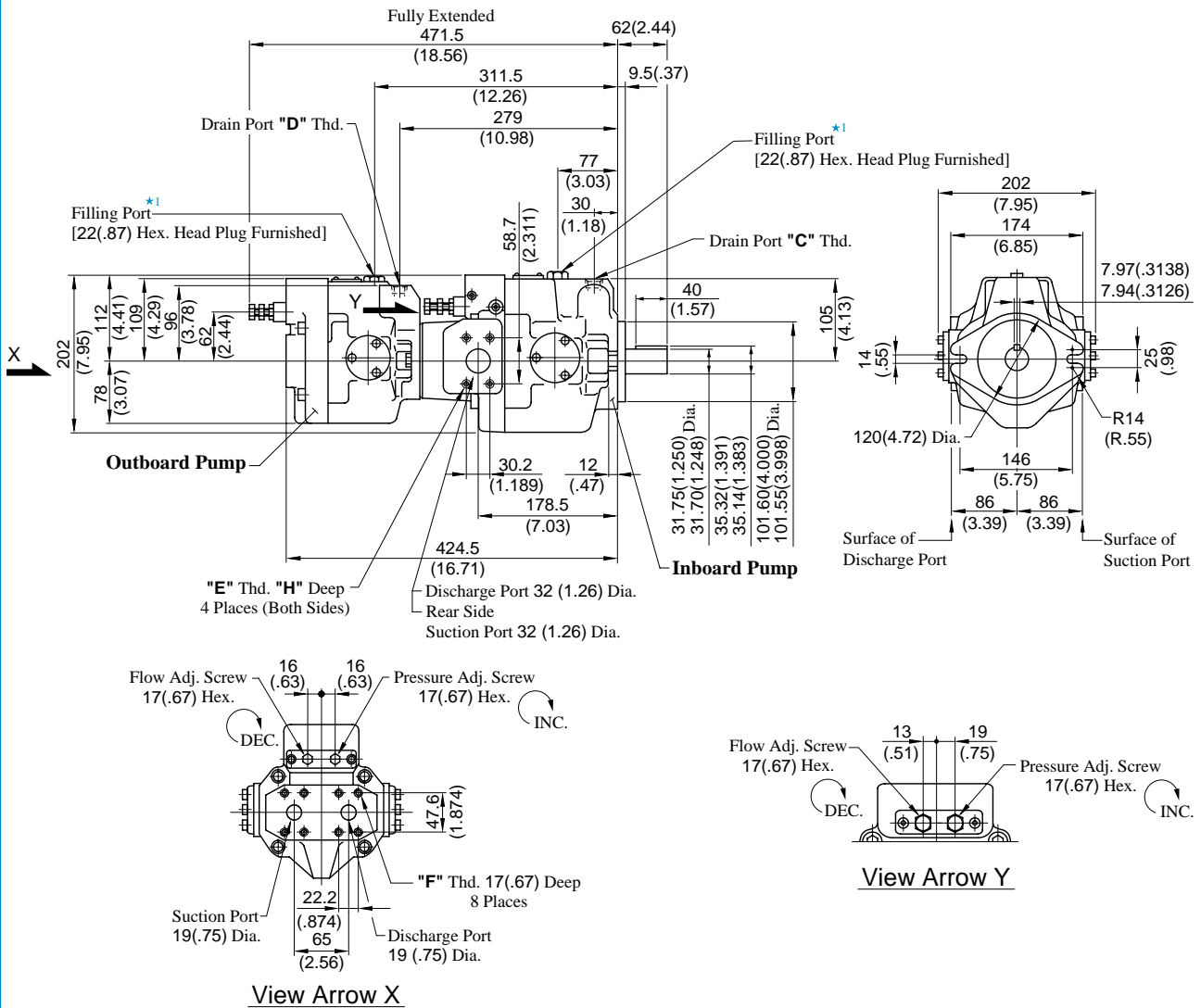

★ 1. Install the pump so that the "Filling Port" is at the top.

Model Numbers	"C" Thd.	"D" Thd.	"E" Thd.	"F" Thd.	"H" mm (IN.)
A1637/A2237-FR01*01*K-32	Rc 1/2	Rc 3/8	M10	M10	19 (.75)
A1637/A2237-FR01*01*K-3280	1/2 BSP.F	3/8 BSP.F			
A1637/A2237-FR01*01*K-3290	1/2 NPT	3/8 NPT	7/16-14 UNC	3/8-16 UNC	20 (.79)

DIMENSIONS IN  
MILLIMETRES (INCHES)

Foot Mtg. : A1637-LR01\*01\*K-32/3280/3290  
A2237-LR01\*01\*K-32/3280/3290

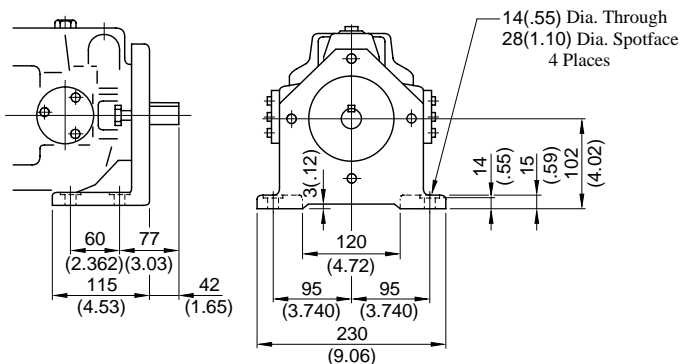

• For other dimensions, refer to "Flange Mtg.".

### Installation Drawing

Flange Mtg. : A1656-FR01\*01\*K-32/3280/3290  
A2256-FR01\*01\*K-32/3280/3290

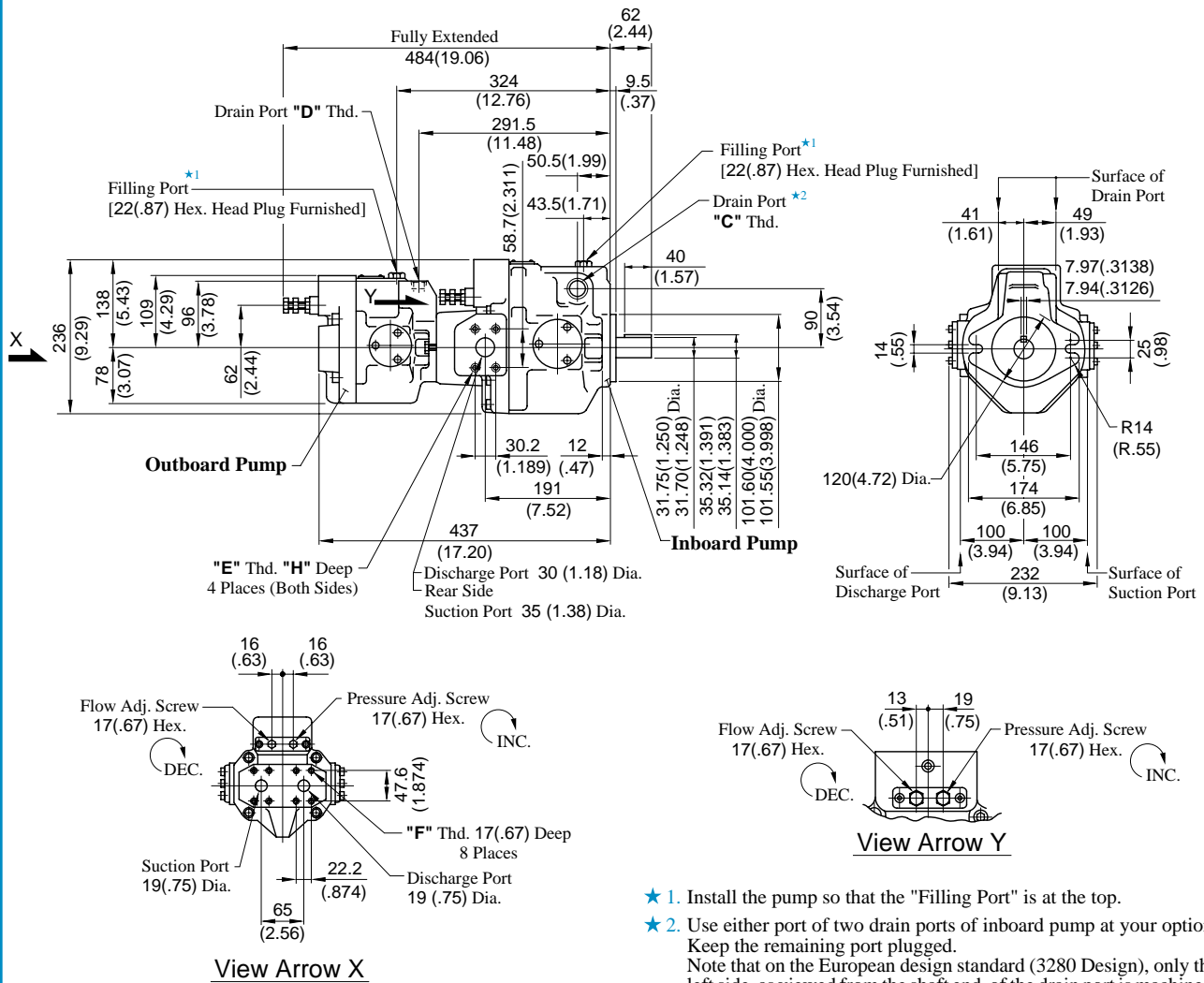

Model Numbers	"C" Thd.	"D" Thd.	"E" Thd.	"F" Thd.	"H" mm (IN.)
A1656/A2256-FR01*01*K-32	Rc 3/4	Rc 3/8	M10	M10	19 (.75)
A1656/A2256-FR01*01*K-3280	3/4 BSP.F	3/8 BSP.F			
A1656/A2256-FR01*01*K-3290	3/4 NPT	3/8 NPT	7/16-14 UNC	3/8-16 UNC	20 (.79)

**DIMENSIONS IN  
MILLIMETRES (INCHES)**

Foot Mtg. : A1656-LR01\*01\*K-32/3280/3290  
A2256-LR01\*01\*K-32/3280/3290

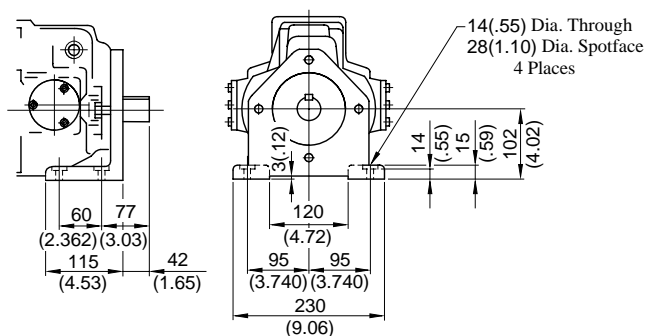

• For other dimensions, refer to "Flange Mtg.".

Flange Mtg. : A1670-FR01\*01\*S-60/6080/6090  
A2270-FR01\*01\*S-60/6080/6090  
A3770-FR01\*01\*S-60/6080/6090

DIMENSIONS IN  
MILLIMETRES (INCHES)

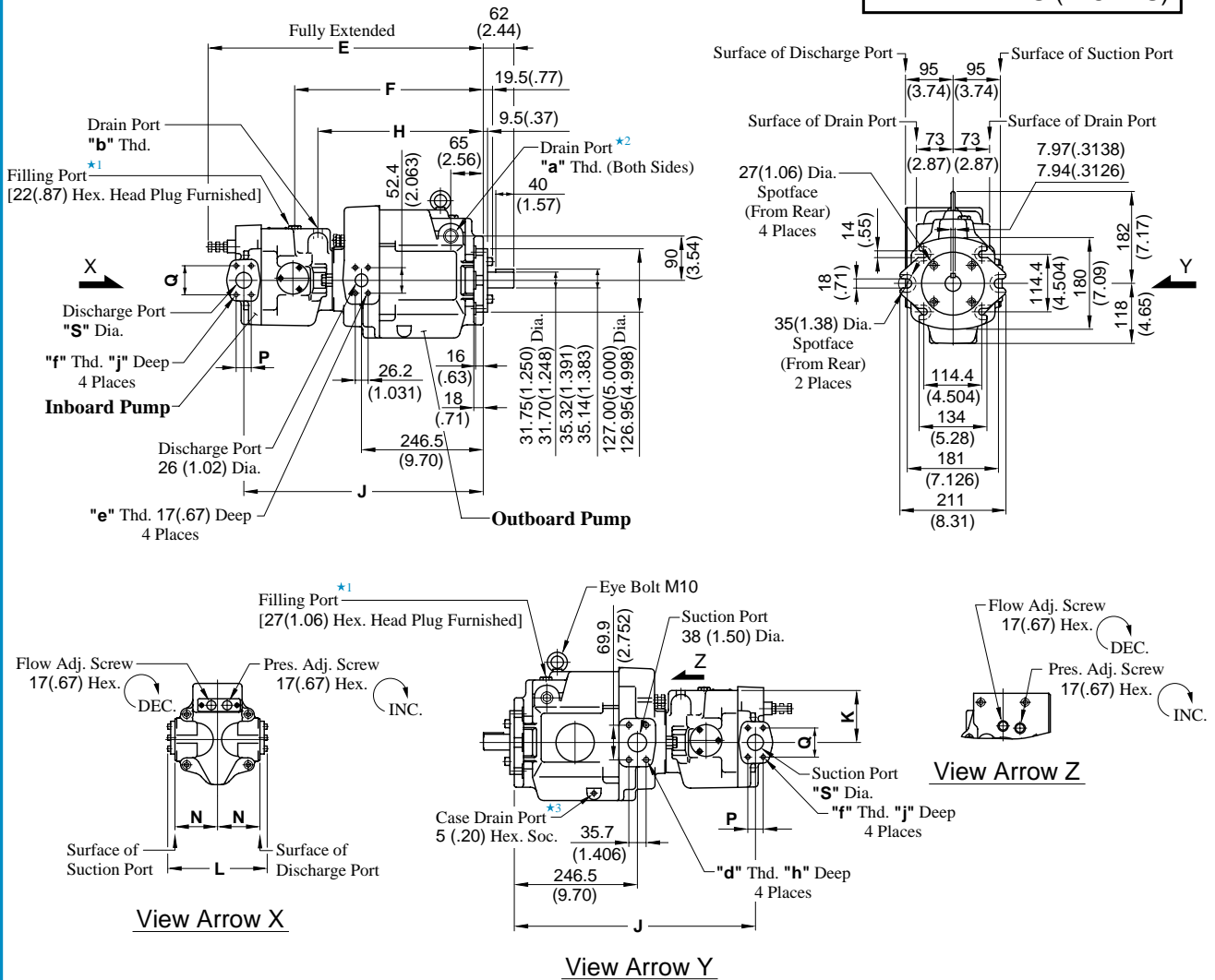

- ★ 1. Install the pump so that the "Filling Port" is at the top.
- ★ 2. Use either port of two drain ports of inboard pump at your option. Keep the remaining port plugged. Note that on the European design standard (6080 Design), only the left side, as viewed from the shaft end, of the drain port of inboard pump is machined.
- ★ 3. Case drain port is available for use when draining hydraulic fluid from pump casing.

Model Numbers	Dimensions mm (Inches)									
	E	F	H	J	K	L	N	P	Q	S
A1670-*R01*01*S-60* A2270-*R01*01*S-60*	524.5 (20.65)	364.5 (14.35)	332 (13.07)	456 (17.95)	96 (3.78)	188 (7.40)	74 (2.91)	22.2 (.874)	47.6 (1.874)	19 (.75)
A3770-*R01*01*S-60*	552.5 (20.65)	382.5 (15.06)	335.5 (13.21)	484 (19.06)	105 (4.13)	202 (7.95)	86 (3.39)	30.2 (1.189)	58.7 (1.311)	32 (1.26)

Model Numbers	Thread Size					mm (Inches)	
	a	b	d	e	f	h	j
A1670/A2270-*R01*01*S-60	Rc 3/4	Rc 3/8	M12	M10	M10	19 (.75)	17 (.67)
A1670/A2270-*R01*01*S-6080	3/4 BSP.F	3/8 BSP.F					
A1670/A2270-*R01*01*S-6090	3/4 NPT	3/8 NPT	1/2-13 UNC	3/8-16 UNC	3/8-16 UNC	21 (.83)	
A3770-*R01*01*S-60	Rc 3/4	Rc 1/2	M12	M10	M10	19 (.75)	19 (.75)
A3770-*R01*01*S-6080	3/4 BSP.F	1/2 BSP.F					
A3770-*R01*01*S-6090	3/4 NPT	1/2 NPT	1/2-13 UNC	3/8-16 UNC	7/16-14 UNC	21 (.83)	20 (.79)

#### ● Foot Mounting Type

The mounting bracket is common that of single pump A70. Refer to page 21 for the dimensions of mounting bracket.

### Installation Drawing

Flange Mtg. : A1690-FR01\*01\*S-60/6080/6090  
A2290-FR01\*01\*S-60/6080/6090  
A3790-FR01\*01\*S-60/6080/6090

**DIMENSIONS IN  
MILLIMETRES (INCHES)**

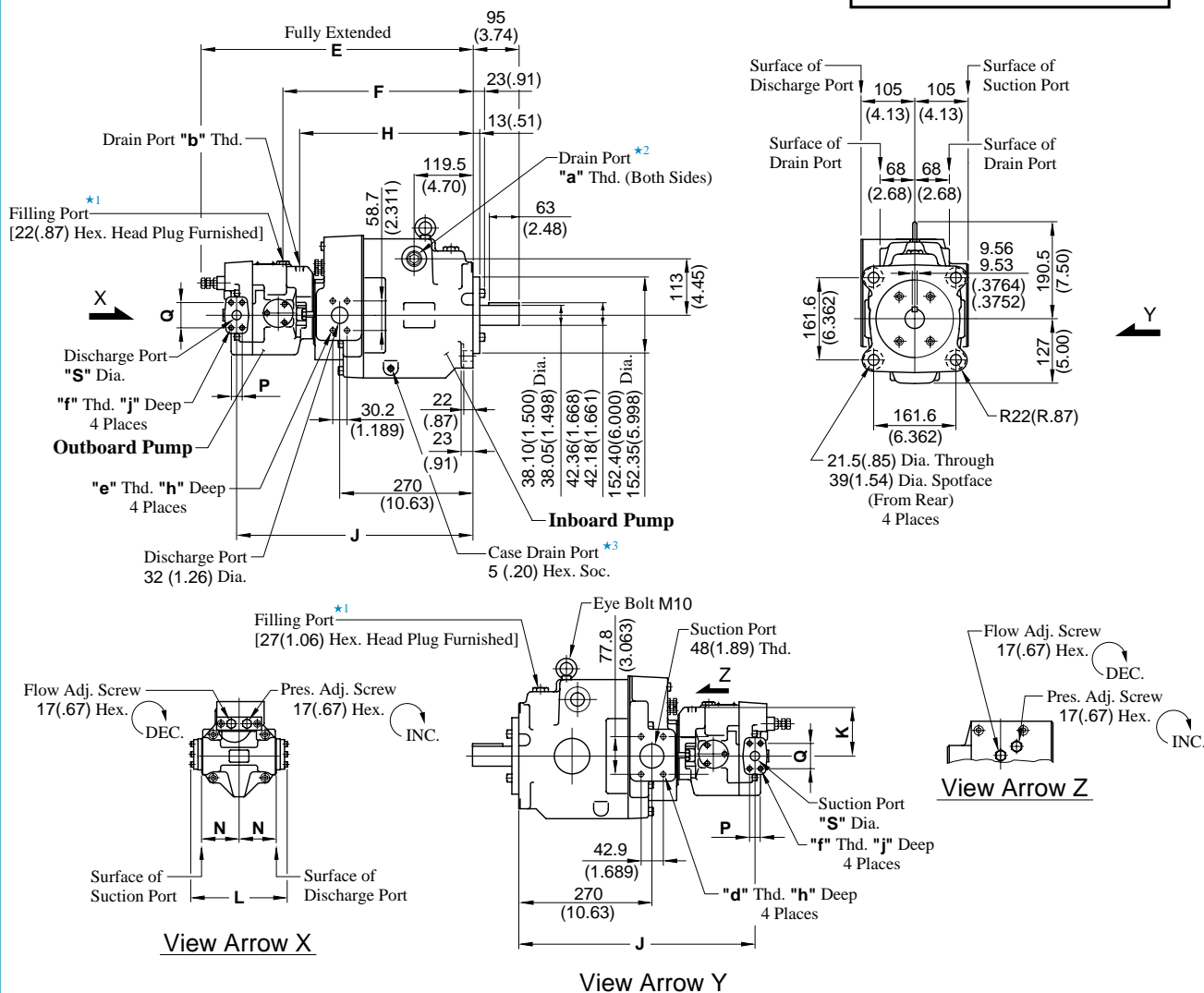

- \*1. Install the pump so that the "Filling Port" is at the top.
- \*2. Use either port of two drain ports of inboard pump at your option. Keep the remaining port plugged. Note that on the European design standard (6080 Design), only the left side, as viewed from the shaft end, of the drain port of inboard pump is machined.
- \*3. Case drain port is available for use when draining hydraulic fluid from pump casing.

Model Numbers	Dimensions mm (Inches)									
	E	F	H	J	K	L	N	P	Q	S
A1690-*R01*01*S-60* A2290-*R01*01*S-60*	543 (21.38)	383 (15.08)	350.5 (13.80)	474.5 (18.68)	96 (3.78)	188 (7.40)	74 (2.91)	22.2 (.874)	47.6 (1.874)	19 (.75)
A3790-*R01*01*S-60*	571 (22.48)	401 (15.79)	354 (13.94)	502.5 (19.78)	105 (4.13)	202 (7.95)	86 (3.39)	30.2 (1.189)	58.7 (1.311)	32 (1.26)

Model Numbers	Thread Size					mm (Inches)	
	a	b	d	e	f	h	j
A1690/A2290-*R01*01*S-60	Rc 3/4	Rc 3/8	M12	M10	M10	19 (.75)	17 (.67)
A1690/A2290-*R01*01*S-6080	3/4 BSP.F	3/8 BSP.F					
A1690/A2290-*R01*01*S-6090	3/4 NPT	3/8 NPT	1/2-13 UNC	7/16-14 UNC	3/8-16 UNC	21 (.83)	
A3790-*R01*01*S-60	Rc 3/4	Rc 1/2	M12	M10	M10	19 (.75)	19 (.75)
A3790-*R01*01*S-6080	3/4 BSP.F	1/2 BSP.F					
A3790-*R01*01*S-6090	3/4 NPT	1/2 NPT	1/2-13 UNC	7/16-14 UNC	7/16-14 UNC	21 (.83)	20 (.79)

#### ● Foot Mounting Type

The mounting bracket is common that of single pump A90. Refer to page 22 for the dimensions of mounting bracket.

Flange Mtg. : A5690-FR01\*01\*S-60/6080/6090

**DIMENSIONS IN  
MILLIMETRES (INCHES)**

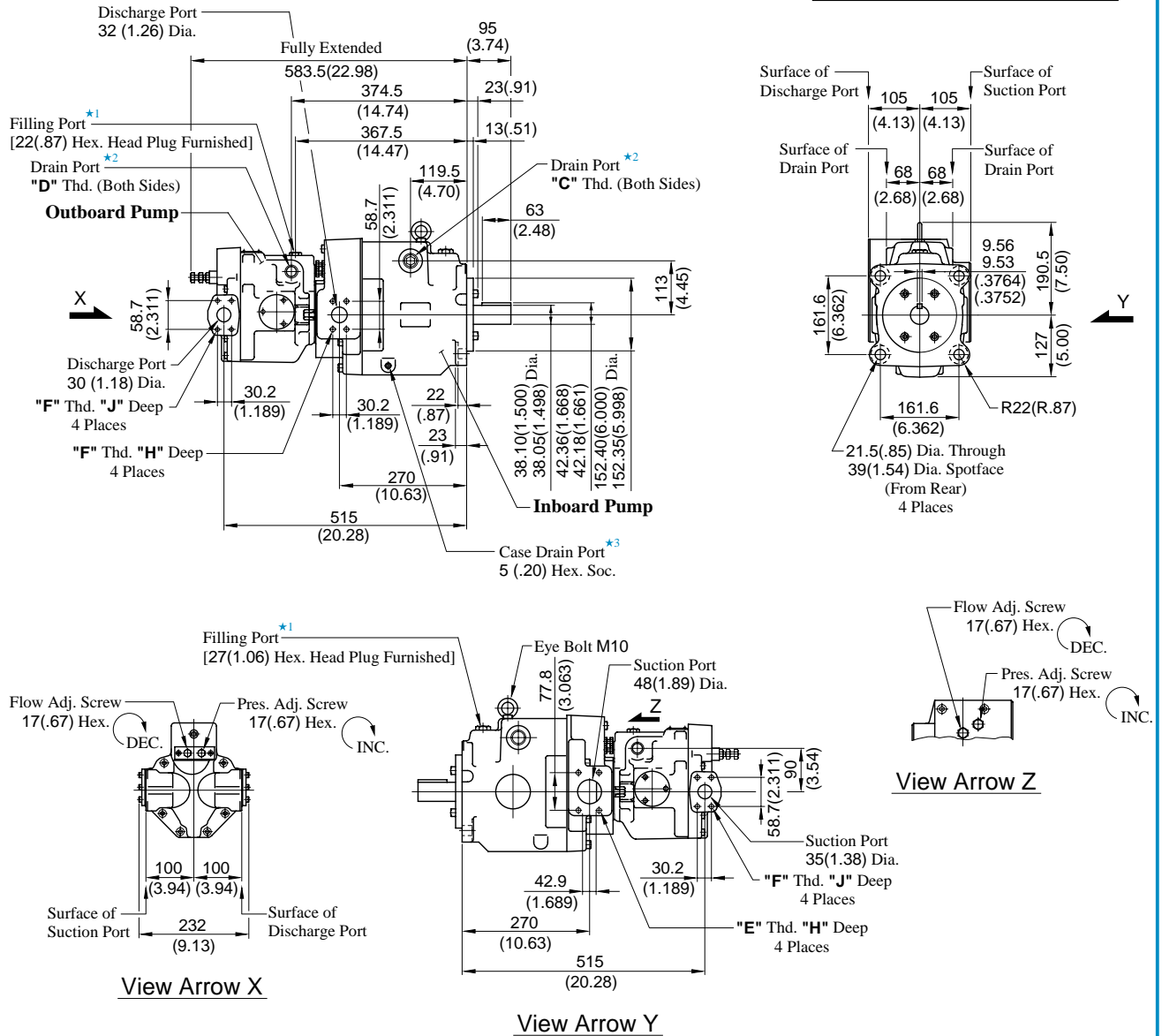

- ★ 1. Install the pump so that the "Filling Port" is at the top.
- ★ 2. Use either port of two drain ports of inboard and outboard pump at your option. Keep the remaining ports plugged. Note that on the European design standard (6080 Design), only the left side, as viewed from the shaft end, of the drain port of inboard and outboard pump is machined.
- ★ 3. Case drain port is available for use when draining hydraulic fluid from pump casing.

Model Numbers	Thread Size				mm (Inches)	
	C	D	E	F	H	J
A5690-*R01*01*S-60	Rc 3/4	Rc 1/2	M12	M10	19 (.75)	19 (.75)
A5690-*R01*01*S-6080	3/4 BSP.F	1/2 BSP.F				
A5690-*R01*01*S-6090	3/4 NPT	1/2 NPT	1/2-13 UNC	7/16-14 UNC	21 (.83)	20 (.79)

#### ● Foot Mounting Type

The mounting bracket is common that of single pump A90. Refer to page 22 for the dimensions of mounting bracket.

### Installation Drawing

Flange Mtg. : A16145-FR01\*01\*S-60/6080/6090  
 A22145-FR01\*01\*S-60/6080/6090  
 A37145-FR01\*01\*S-60/6080/6090

**DIMENSIONS IN  
MILLIMETRES (INCHES)**

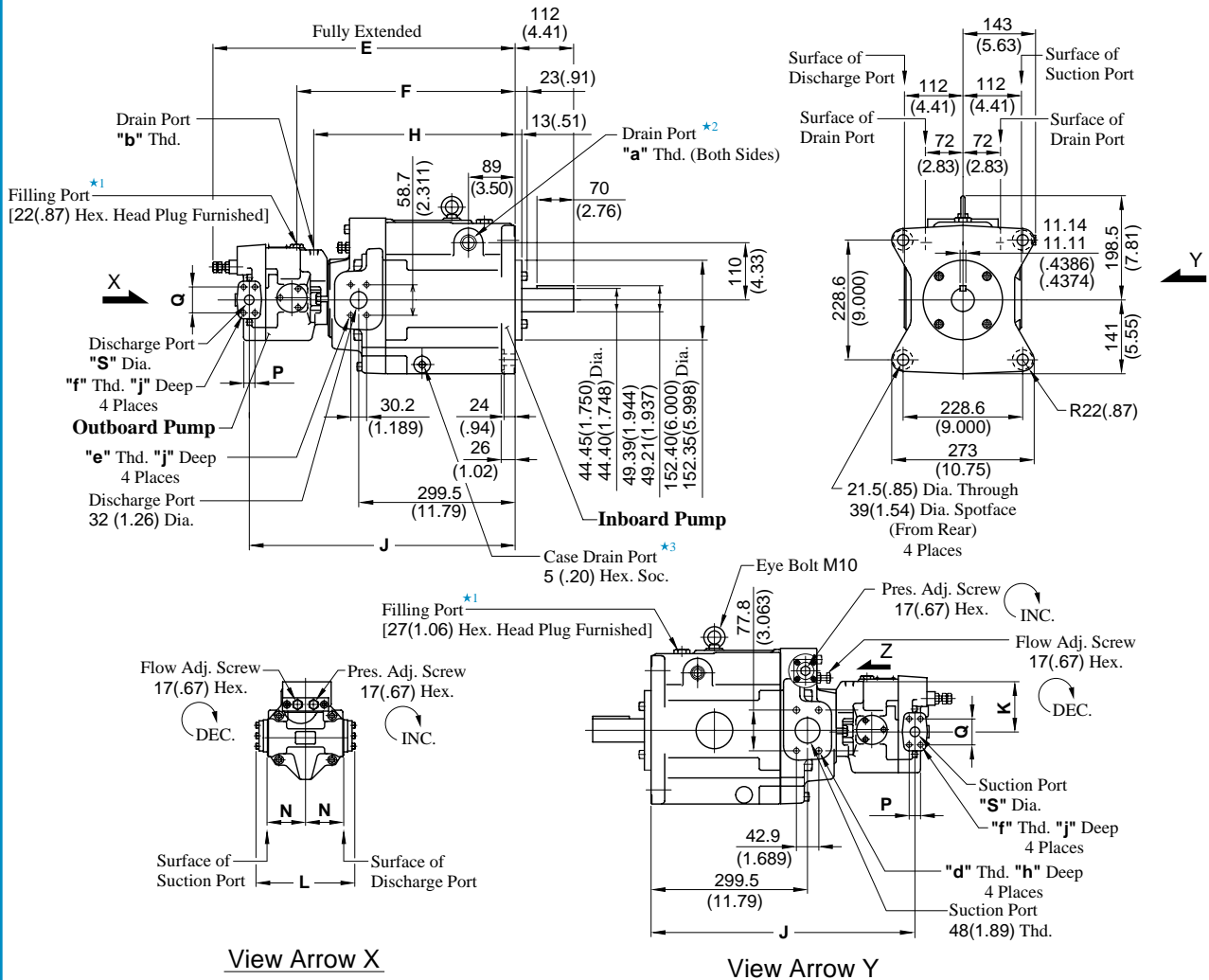

- ★ 1. Install the pump so that the "Filling Port" is at the top.
- ★ 2. Use either port of two drain ports of inboard pump at your option. Keep the remaining port plugged. Note that on the European design standard (6080 Design), only the left side, as viewed from the shaft end, of the drain port of inboard pump is machined.
- ★ 3. Case drain port is available for use when draining hydraulic fluid from pump casing.

Model Numbers	Dimensions mm (Inches)									
	E	F	H	J	K	L	N	P	Q	S
A16145-*R01*01*S-60* A22145-*R01*01*S-60*	576.5 (22.70)	416.5 (16.40)	384 (15.12)	508 (20.00)	96 (3.78)	188 (7.40)	74 (2.91)	22.2 (.874)	47.6 (1.874)	19 (.75)
A37145-*R01*01*S-60*	604.5 (23.80)	434.5 (17.11)	387.5 (15.26)	536 (21.10)	105 (4.13)	202 (7.95)	86 (3.39)	30.2 (1.189)	58.7 (1.311)	32 (1.26)

Model Numbers	Thread Size					mm (Inches)				
	a	b	d	e	f	h	j	n		
A16145/A22145-*R01*01*S-60	Rc 3/4	Rc 3/8	M12	M10	M10	19 (.75)	19 (.75)	17 (.67)		
A16145/A22145-*R01*01*S-6080	3/4 BSP.F	3/8 BSP.F								
A16145/A22145-*R01*01*S-6090	3/4 NPT	3/8 NPT	1/2-13 UNC	7/16-14 UNC	3/8-16 UNC	21 (.83)	20 (.79)			
A37145-*R01*01*S-60	Rc 3/4	Rc 1/2	M12	M10	M10	19 (.75)	19 (.75)	19 (.75)		
A37145-*R01*01*S-6080	3/4 BSP.F	1/2 BSP.F								
A37145-*R01*01*S-6090	3/4 NPT	1/2 NPT	1/2-13 UNC	7/16-14 UNC	7/16-14 UNC	21 (.83)	20 (.79)			

#### ● Foot Mounting Type

The mounting bracket is common that of single pump A145. Refer to page 23 for the dimensions of mounting bracket.



Flange Mtg. : A56145-FR01\*01\*S-60/6080/6090

**DIMENSIONS IN  
MILLIMETRES (INCHES)**

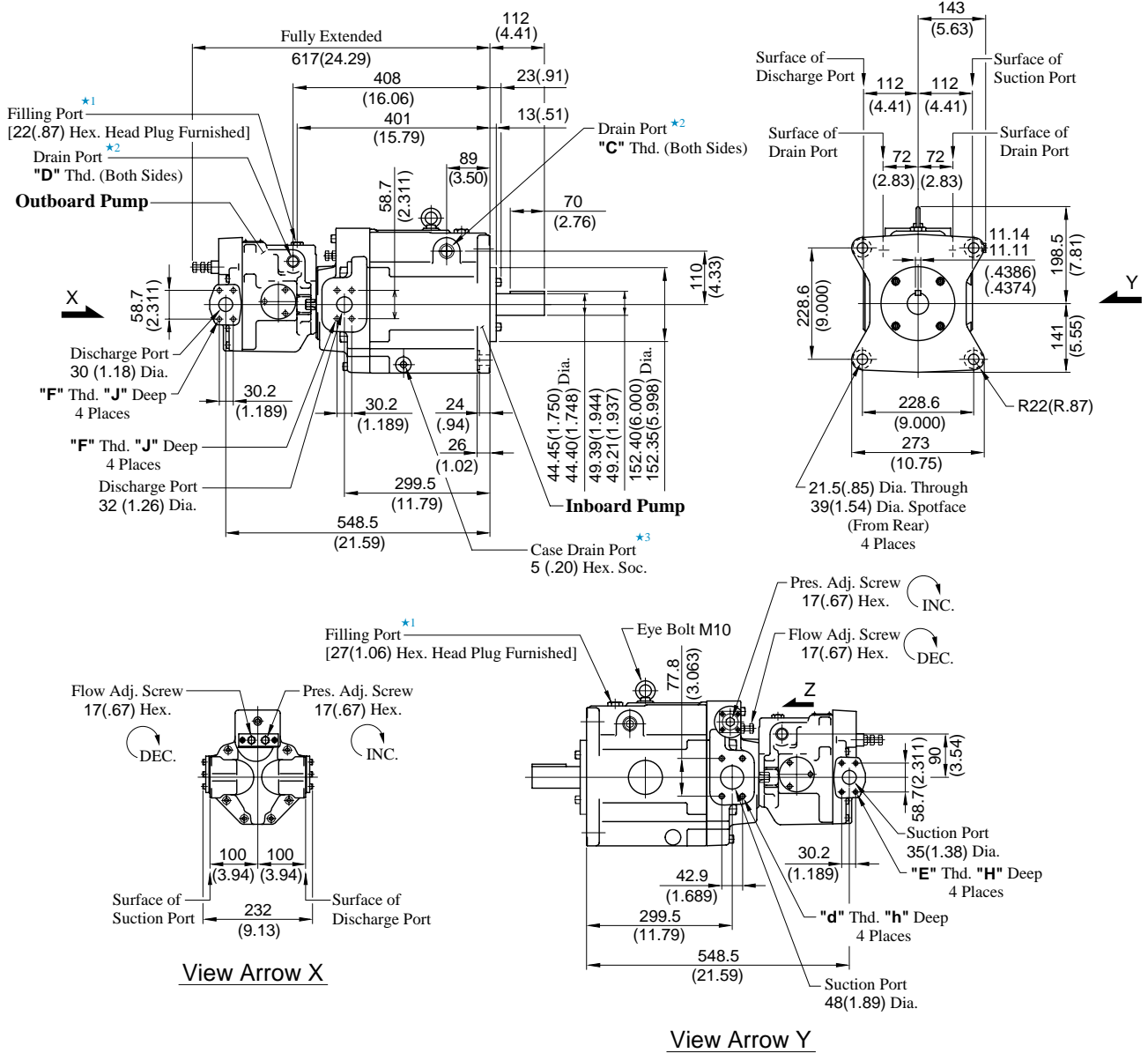

- ★ 1. Install the pump so that the "Filling Port" is at the top.
- ★ 2. Use either port of two drain ports of inboard and outboard pump at your option. Keep the remaining ports plugged. Note that on the European design standard (6080 Design), only the left side, as viewed from the shaft end, of the drain port of inboard and outboard pump is machined.
- ★ 3. Case drain port is available for use when draining hydraulic fluid from pump casing.

Model Numbers	Thread Size				mm (Inches)	
	C	D	E	F	H	J
A56145-*R01*01*S-60	Rc 3/4	Rc 1/2	M12	M10	19 (.75)	19 (.75)
A56145-*R01*01*S-6080	3/4 BSP.F	1/2 BSP.F				
A56145-*R01*01*S-6090	3/4 NPT	1/2 NPT	1/2-13 UNC	7/16-14 UNC	21 (.83)	20 (.79)

#### ● Foot Mounting Type

The mounting bracket is common that of single pump A145. Refer to page 23 for the dimensions of mounting bracket.

A1616-\*R01\*01\*\*K-32/3280/3290  
 A\*\*22-\*R01\*01\*\*K-32/3280/3290  
 A\*\*37-\*R01\*01\*\*K-32/3280/3290  
 A\*\*56-\*R01\*01\*\*K-32/3280/3290  
 A\*\*70-\*R01\*01\*\*-60/6080/6090  
 A\*\*90-\*R01\*01\*\*-60/6080/6090  
 A\*\*145-\*R01\*01\*\*-60/6080/6090

### ⚠ CAUTION

When making replacement of seals or bearings, please do it carefully after reading through the relevant instructions in the Operator's Manual.

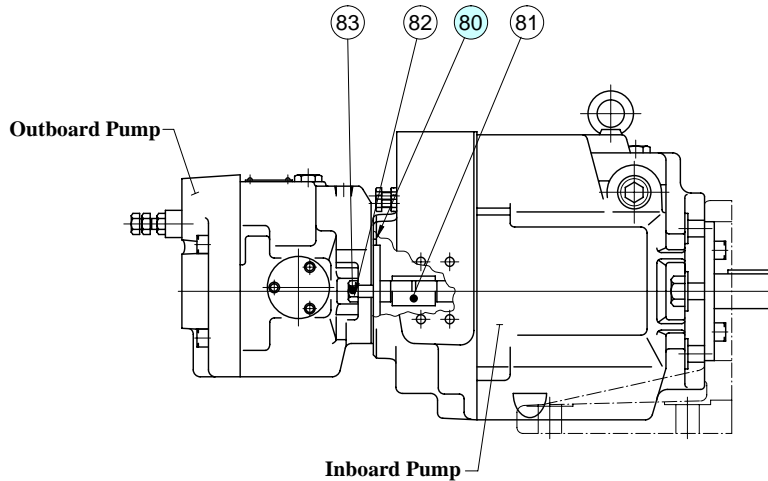

### ● Seals

Pump Model Numbers	Seal Kit Numbers			Item 80 O-Ring	
	Complete Kit	For Outboard Pump	For Inboard Pump	Part Numbers	Qty.
A1616-*R01*01**K-32* A1622-*R01*01**K-32* A2222-*R01*01**K-32*	KS-A1616-0101-32	KS-A16-01-32	KS-A16-01-32	S85(NBR,Hs70)	1
A1637-*R01*01**K-32* A2237-*R01*01**K-32*	KS-A1637-0101-32	KS-A16-01-32	KS-A37-01-32	S85(NBR,Hs70)	1
A1656-*R01*01**K-32* A2256-*R01*01**K-32*	KS-A1656-0101-32	KS-A16-01-32	KS-A56-01-32	S85(NBR,Hs70)	1
A1670-*R01*01**-60* A2270-*R01*01**-60*	KS-A1670-0101-60	KS-A16-01-32	KS-A70-01-60	S85(NBR,Hs70)	1
A3770-*R01*01**-60*	KS-A3770-0101-60	KS-A37-01-32		S105(NBR,Hs70)	1
A1690-*R01*01**-60* A2290-*R01*01**-60*	KS-A1690-0101-60	KS-A16-01-32	KS-A90-01-60	S85(NBR,Hs70)	1
A3790-*R01*01**-60*	KS-A3790-0101-60	KS-A37-01-32		S105(NBR,Hs70)	1
A5690-*R01*01**-60*	KS-A5690-0101-60	KS-A56-01-32	KS-A145-01-60	S85(NBR,Hs70)	1
A16145-*R01*01**-60* A22145-*R01*01**-60*	KS-A16145-0101-60	KS-A16-01-32			
A37145-*R01*01**-60*	KS-A37145-0101-60	KS-A37-01-32		S105(NBR,Hs70)	1
A56145-*R01*01**-60*	KS-A56145-0101-60	KS-A56-01-32			

Notes :1 When ordering seals, please specify the seal kit number from the table above.

2 Complete seal kit consists of a seal kit for inboard pump, a seal kit for outboard pump and a piece of O-ring for item 80.

3 Seal kit and bearings for inboard pump and outboard pump are same as those for "A" series single pump. For details, please refer to the table below and see the chart on the page relevant to pump model number concerned.

Model	Inboard Pump	Model	Outboard Pump
A16**	Same as single pump "A16" (Page 25)	A1616	Same as single pump "A16" (Page 25)
A22**	Same as single pump "A22" (Page 25)	A**22	Same as single pump "A22" (Page 25)
A37**	Same as single pump "A37" (Page 25)	A**37	Same as single pump "A37" (Page 25)
A56**	Same as single pump "A56" (Page 25)	A**56	Same as single pump "A56" (Page 25)
		A**70	Same as single pump "A70" (Page 26)
		A**90	Same as single pump "A90" (Page 26)
		A**145	Same as single pump "A145" (Page 27)

#### Model Number Designation

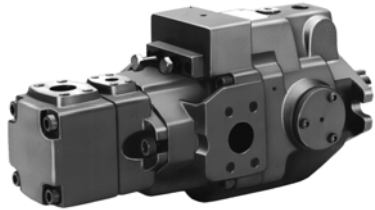

Graphic Symbol

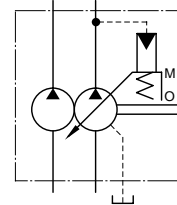

#### Model Number Designation

A16R1	-F	R	Inboard Pump (Driven End)		Outboard Pump			K	-32	*
			01	B	-23	A	A			
Series Number	Mounting	Direction of Rotation	Control Type	Pres. Adj. Range MPa(PSI)	Nominal Displacement cm <sup>3</sup> /rev	Discharge Port Position	Suction Port Position	Shaft Extension	Design Number	Design Std.
A16R1	F: Flange Mtg. L: Foot Mtg.	(Viewed from Shaft End) R: ★1 Clockwise (Normal)	01: Pressure Compensator Type	B: 1.2 - 7 (170 - 1020) C: 1.2 - 16 (170 - 2320) H: 1.2 - 21 (170 - 3050)	6, 8 10, 12 14, 17 19, 23 25, 31	A: Up	A: Up	K: Keyed Shaft	32	Refer to ★2
A22R1				B: 1.2 - 7 (170 - 1020) C: 1.2 - 16 (170 - 2320)					32	
A37R1				B: 1.2 - 7 (170 - 1020) C: 1.2 - 16 (170 - 2320) H: 1.2 - 21 (170 - 3050)					32	
A56R1				B: 1.2 - 7 (170 - 1020) C: 1.2 - 16 (170 - 2320) H: 1.2 - 21 (170 - 3050)					32	
A70R1				B: 1.2 - 7 (170 - 1020) C: 1.5 - 16 (220 - 2320) H: 1.8 - 21 (260 - 3050) K: 2.0 - 28 (290 - 4060)					60	
A90R1				B: 1.2 - 7 (170 - 1020) C: 1.5 - 16 (220 - 2320) H: 1.8 - 21 (260 - 3050) K: 2.0 - 28 (290 - 4060)					60	
A145R1				B: 1.2 - 7 (170 - 1020) C: 1.5 - 16 (220 - 2320) H: 1.8 - 21 (260 - 3050) K: 2.0 - 28 (290 - 4060)					60	
A70R2				B: 1.2 - 7 (170 - 1020) C: 1.5 - 16 (220 - 2320) H: 1.8 - 21 (260 - 3050) K: 2.0 - 28 (290 - 4060)					60	
A90R2				B: 1.2 - 7 (170 - 1020) C: 1.5 - 16 (220 - 2320) H: 1.8 - 21 (260 - 3050) K: 2.0 - 28 (290 - 4060)					60	
A145R2	B: 1.2 - 7 (170 - 1020) C: 1.5 - 16 (220 - 2320) H: 1.8 - 21 (260 - 3050) K: 2.0 - 28 (290 - 4060)	60								

★1. Available to supply pump with anti-clockwise rotation. Consult Yuken for details.

★2. Design Standards: None ..... Japanese Standard "JIS"  
80 ..... European Design Standard  
90 ..... N. American Design Standard

### Specifications

#### ■ Specifications

Model Numbers	Geometric Displacement cm <sup>3</sup> /rev (cu.in./rev)	Operating Pressure MPa (PSI)		Shaft Speed Range r/min		Approx. Mass kg (lbs.)	
		Rated <sup>*2</sup>	Intermittent <sup>*1</sup>	Max.	Min.	Flange Mtg.	Foot Mtg.
A16R1-*R01*-*AAK-32* <sup>*3</sup>	Outboard Pump	Refer to the following page		1800	750	28.8 (63.5)	31.0 (68.4)
	Inboard Pump	15.8 (.964)	16 (2320) 21 (3050)				
A22R1-*R01*-*AAK-32* <sup>*3</sup>	Outboard Pump	Refer to the following page		1800	750	28.8 (63.5)	31.0 (68.4)
	Inboard Pump	22.2 (1.355)	16 (2320) 16 (2320)				
A37R1-*R01*-*AAK-32* <sup>*3</sup>	Outboard Pump	Refer to the following page		1800	750	39 (86.0)	43.3 (95.5)
	Inboard Pump	36.9 (2.25)	16 (2320) 21 (3050)				
A56R1-*R01*-*AAK-32* <sup>*3</sup>	Outboard Pump	Refer to the following page		1800	750	47 (104)	51.3 (113)
	Inboard Pump	56.2 (3.43)	16 (2320) 21 (3050)				
A70R1-*R01*-*AA-60* <sup>*3</sup>	Outboard Pump	Refer to the following page		1800	750	66 (146)	78 (172)
	Inboard Pump	70.0 (4.27)	25 (3630) 28 (4060)				
A90R1-*R01*-*AA-60* <sup>*3</sup>	Outboard Pump	Refer to the following page		1800	750	82 (181)	105 (232)
	Inboard Pump	91.0 (5.55)	25 (3630) 28 (4060)				
A145R1-*R01*-*AA-60* <sup>*3</sup>	Outboard Pump	Refer to the following page		1800	750	102 (225)	129 (284)
	Inboard Pump	145 (8.85)	25 (3630) 28 (4060)				
A70R2-*R01*-*AA-60* <sup>*3</sup>	Outboard Pump	Refer to the following page		1800	600	72.5 (160)	84.5 (186)
	Inboard Pump	70.0 (4.27)	25 (3630) 28 (4060)				
A90R2-*R01*-*AA-60* <sup>*3</sup>	Outboard Pump	Refer to the following page		1800	600	91.5 (202)	112 (247)
	Inboard Pump	91.0 (5.55)	25 (3630) 28 (4060)				
A145R2-*R01*-*AA-60* <sup>*3</sup>	Outboard Pump	Refer to the following page		1800	600	112 (247)	137 (302)
	Inboard Pump	145 (8.85)	25 (3630) 28 (4060)				

- ★ 1. Whenever setting pressure, make sure the full cut-off pressure never exceeds the maximum intermittent pressure.
- ★ 2. Care should be taken in cases of use at a higher pressure than the rated pressure, because operating terms may be restricted. For example, if used as per maximum illustrated operating conditions, intermittent time at maximum flow is restricted to under 1/5 of one cycle time and under 6 seconds simultaneously. Conditions may vary according to the actual working pressure and delivery (inclination angle of the swash plate). Consult factory or Yuken sales representative for further information.

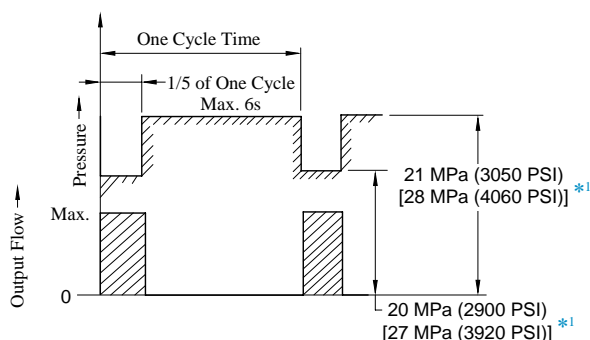

\*1. Applicable only for A70R1/R2, A90R1/R2, A145R1/R2.

- ★ 3. The maximum input power of except "A56R1" pump must be restricted, because of the shaft strength. Refer to the following page.

### ■ Allowable Input Power

With the pumps listed in the table below, there is a limit to the sum of the input power of the inboard and outboard pumps because of shaft strength.

If both pumps are used for boosting at once, referring to the calculation formulas below, check that the displacements and discharge pressures of both pumps are within the allowable ranges.

$$Q1 \times P1 + Q2 \times P2 \leq L_M$$

Q1 : Displacement (cm<sup>3</sup>/rev)  
P1 : Discharge Pressure (MPa) } Outboard Pump  
Q2 : Displacement (cm<sup>3</sup>/rev)  
P2 : Discharge Pressure (MPa) } Inboard Pump  
L<sub>M</sub> : See the table below

$$Q1 \times P1 + Q2 \times P2 \leq L_P$$

Q1 : Displacement (cu.in/rev)  
P1 : Discharge Pressure (PSI) } Outboard Pump  
Q2 : Displacement (cu.in/rev)  
P2 : Discharge Pressure (PSI) } Inboard Pump  
L<sub>P</sub> : See the table below

Model Numbers	L <sub>M</sub>	L <sub>P</sub>
A16R1/A22R1	523	4627
A37R1	900	7963
A70R1/A70R2	2408	21305
A90R1/A90R2	4348	38470
A145R1/A145R2	4739	41930

### ● Geometric Displacement and Max. Pressure of Outboard Pump

Model Numbers	Geometric Displacement cm <sup>3</sup> /rev (cu.in./rev)	Max Pres. MPa (PSI)	
		Anti-Wear Type	R & O Type
A*R1-*R01*-6	5.8 (.354)	21 *1 (3050)	16 (2320)
A*R1-*R01*-8	8.0 (.488)		
A*R1-*R01*-10	9.4 (.574)		
A*R1-*R01*-12	12.2 (.744)		
A*R1-*R01*-14	13.7 (.836)		
A*R1-*R01*-17	16.6 (1.013)		
A*R1-*R01*-19	18.6 (1.135)		
A*R1-*R01*-23	22.7 (1.385)	17.5 (2540)	15 (2180)
A*R1-*R01*-25	25.3 (1.544)	15 (2180)	
A*R1-*R01*-31	31.0 (1.892)	12 (1740)	
A*R2-*R01*-26	26.6 (1.623)	21 (3050)	14 (2030)
A*R2-*R01*-33	33.3 (2.03)		
A*R2-*R01*-41	41.3 (2.52)		
A*R2-*R01*-47	47.2 (2.88)	20 (2900)	
A*R2-*R01*-53	52.5 (3.20)	18 (2610)	
A*R2-*R01*-59	58.2 (3.55)	16 (2320)	
A*R2-*R01*-65	64.7 (3.95)	14 (2030)	

★ 1. When pump is operated pressure more than 16 MPa (2320 PSI), shaft speed should be more than 1450 r/min.

### ■ Instructions

#### ● Suction Pressure of Outboard Pump

Permissible suction pressure at inlet port of the outboard pump (PV2R) is the range between -20 kPa and +30 kPa (5.9 in. Hg vacuum and +4.3 PSIG).

#### ● Suction Piping of Outboard Pump

When the operating speed is less than 1200 r/min, the suction port of the outboard pump (PV2R) should be facing upwards to facilitate oil suction when starting.

#### ● When Starting the pump at low speed

maximum viscosity is restricted. Refer to the table below.

Model	Start-up Speed r/min	Max. Viscosity mm <sup>2</sup> /s (SSU)
A*R1	750	100 (465)
	950	200 (930)
A*R2	600	100 (465)
	950	200 (930)

### ■ Performance Characteristics

Performance characteristics of inboard pump refer to relevant page for performance characteristics of "A" series single pumps excluding noise level characteristics.

Performance characteristics of outboard pump refer to "PV2R" series vane pump catalogue (catalogue No. Pub. EC-0118).

Model	Performance Characteristics	
	Inboard Pump	Outboard Pump
A16R1	Same as Single Pump "A16", Refer to Page 10	Same as Vane Type Single Pump "PV2R1". Refer to the Catalogue No. Pub.EC-0118.
A22R1	Same as Single Pump "A22", Refer to Page 11	
A37R1	Same as Single Pump "A37", Refer to Page 12	
A56R1	Same as Single Pump "A56", Refer to Page 13	
A70R1	Same as Single Pump "A70", Refer to Page 14	
A90R1	Same as Single Pump "A90", Refer to Page 15	
A145R1	Same as Single Pump "A145", Refer to Page 16	
A70R2	Same as Single Pump "A70", Refer to Page 14	Same as Vane Type Single Pump "PV2R2". Refer to the Catalogue No. Pub.EC-0118.
A90R2	Same as Single Pump "A90", Refer to Page 15	
A145R2	Same as Single Pump "A145", Refer to Page 16	

### ■ Pipe Flange Kits

Pipe flange kits are available. When ordering, specify the kit number from the table below.

#### ● For Inboard Pump ("A" Pump)

Pump Model Numbers	Name of Port	Pipe Flange Kit Numbers						
		Threaded Connection			Socket Welding*		Butt Welding	
		Japanese Std. "JIS"	European Design Std.	N. American Design Std.	Japanese Std. "JIS" & European Design Std.	N. American Design Std.	Japanese Std. "JIS" & European Design Std.	N. American Design Std.
A16R1	Suction	F5-06-A-10	F5-06-A-1080	F5-06-A-1090	F5-06-B-10	F5-06-B-1090	F5-06-C-10	F5-06-C-1090
A22R1	Discharge	F5-06-A-10	F5-06-A-1080	F5-06-A-1090	F5-06-B-10	F5-06-B-1090	F5-06-C-10	F5-06-C-1090
A37R1	Suction	F5-10-A-10	F5-10-A-1080	F5-10-A-1090	F5-10-B-10	F5-10-B-1090	F5-10-C-10	F5-10-C-1090
A56R1	Discharge	F5-10-A-10	F5-10-A-1080	F5-10-A-1090	F5-10-B-10	F5-10-B-1090	F5-10-C-10	F5-10-C-1090
A70R1	Suction	F5-12-A-10	F5-12-A-1080	F5-12-A-1090	F5-12-B-10	F5-12-B-1090	F5-12-C-10	F5-12-C-1090
	Discharge	F5-08-A-10	F5-08-A-1080	F5-08-A-1090	F5-08-B-10	F5-08-B-1090	F5-08-C-10	F5-08-C-1090
A90R1	Suction	F5-16-A-10	F5-16-A-1080	F5-16-A-1090	F5-16-B-10	F5-16-B-1090	F5-16-C-10	F5-16-C-1090
A145R1	Discharge	F5-10-A-10	F5-10-A-1080	F5-10-A-1090	F5-10-B-10	F5-10-B-1090	F5-10-C-10	F5-10-C-1090

#### ● For Outboard Pump (PV2R Pump)

Pump Model Numbers	Name of Port	Pipe Flange Kit Numbers						
		Threaded Connection			Socket Welding*		Butt Welding	
		Japanese Std. "JIS"	European Design Std.	N. American Design Std.	Japanese Std. "JIS" & European Design Std.	N. American Design Std.	Japanese Std. "JIS" & European Design Std.	N. American Design Std.
A16R1 A22R1 A37R1 A56R1 A70R1 A90R1 A145R1	Suction	F5-08-A-10	F5-08-A-1080	F5-08-A-1090	F5-08-B-10	F5-08-B-1090	F5-08-C-10	F5-08-C-1090
	Discharge	F5-04-A-10	F5-04-A-1080	F5-04-A-1090	F5-04-B-10	F5-04-B-1090	F5-04-C-10	F5-04-C-1090
A70R2 A90R2	Suction	F5-10-A-10	F5-10-A-1080	F5-10-A-1090	F5-10-B-10	F5-10-B-1090	F5-10-C-10	F5-10-C-1090
A145R2	Discharge	F5-06-A-10	F5-06-A-1080	F5-06-A-1090	F5-06-B-10	F5-06-B-1090	F5-06-C-10	F5-06-C-1090

\* In case of using socket welding flanges, there is a case where the operating pressure should be set lower than the normal because of strength of the flanges. Therefore, please pay cautious attention to the operating pressure when the socket welding flanges are used.

● Details of the pipe flange kits are given in the Catalogue No. Pub. EC-3001.

Flange Mtg. : A16R1-FR01\*-\*AAK-32/3280/3290  
A22R1-FR01\*-\*AAK-32/3280/3290

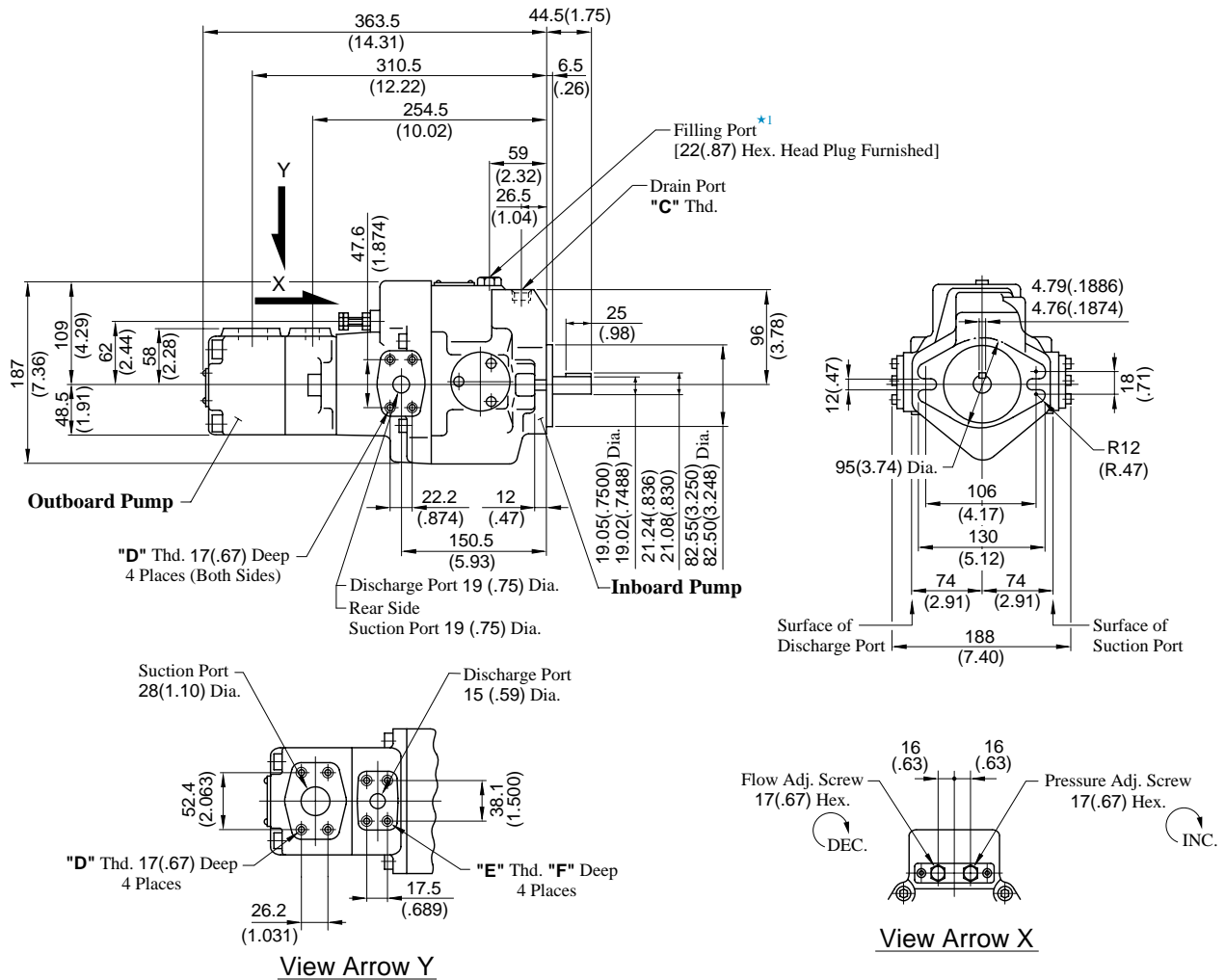

★ 1. Install the pump so that the "Filling Port" is at the top.

Model Numbers	"C" Thd.	"D" Thd.	"E" Thd.	F mm (IN.)
A16R1/A22R1-FR01*-*AAK-32	Rc 3/8	M10	M8	14 (.55)
A16R1/A22R1-FR01*-*AAK-3280	3/8 BSP.F			
A16R1/A22R1-FR01*-*AAK-3290	3/8 NPT	3/8-16 UNC	5/16-18 UNC	16 (.63)

**DIMENSIONS IN  
MILLIMETRES (INCHES)**

Foot Mtg. : A16R1-LR01\*-\*AAK-32/3280/3290  
A22R1-LR01\*-\*AAK-32/3280/3290

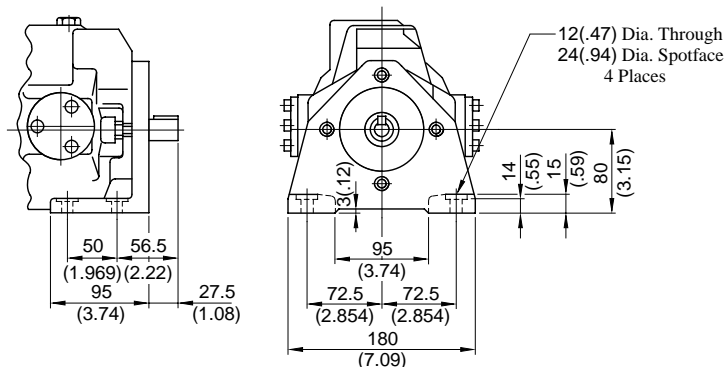

• For other dimensions, refer to "Flange Mtg.".

**Installation Drawing**

Flange Mtg. : A37R1-FR01\*-\*AAK-32/3280/3290

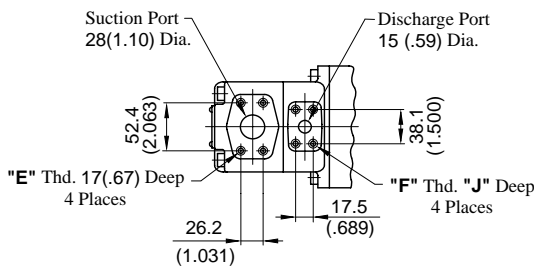
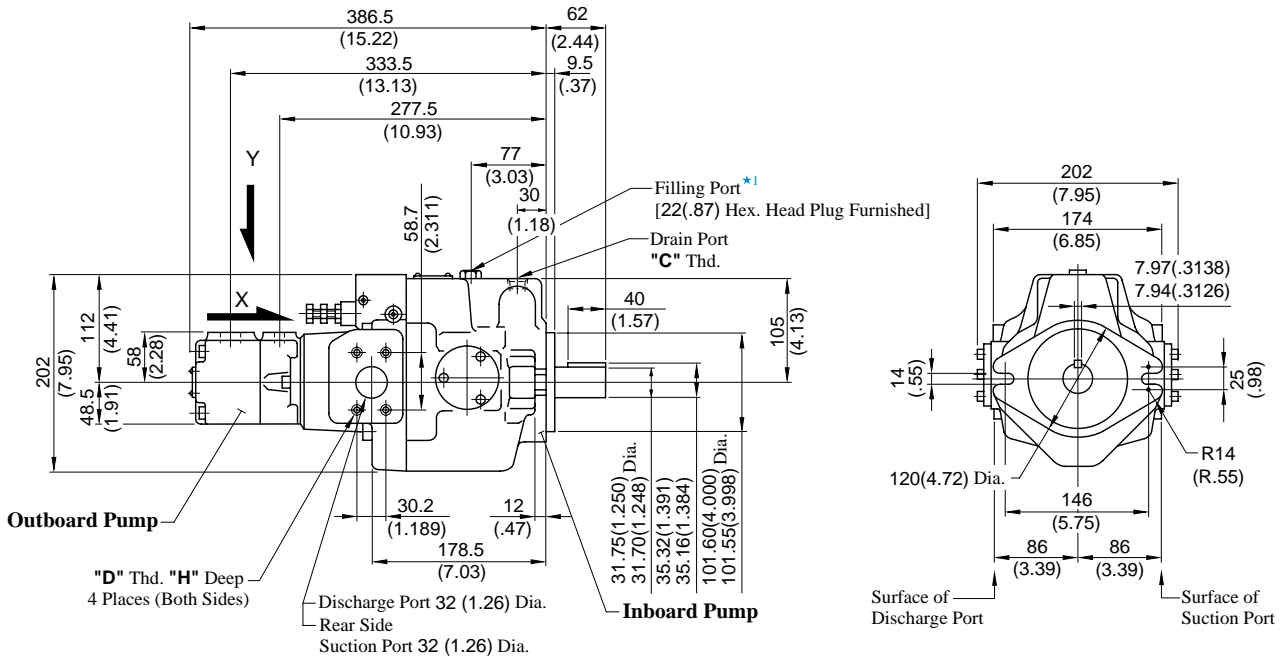

**View Arrow Y**

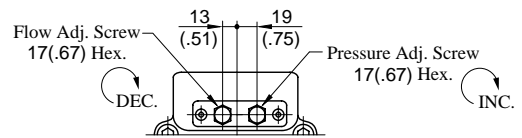

**View Arrow X**

★ 1. Install the pump so that the "Filling Port" is at the top.

Model Numbers	"C" Thd.	"D" Thd.	"E" Thd.	"F" Thd.	mm (IN.)	
					H	J
A37R1-FR01*-*AAK-32	Rc 1/2	M10	M10	M8	19 (.75)	14 (.55)
A37R1-FR01*-*AAK-	1/2 BSP.F					
3280	1/2 NPT	7/16-14 UNC	3/8-16 UNC	5/16-18 UNC	20 (.79)	16 (.63)

**DIMENSIONS IN  
MILLIMETRES (INCHES)**

Foot Mtg. : A37R1-LR01\*-\*AAK-32/3280/3290

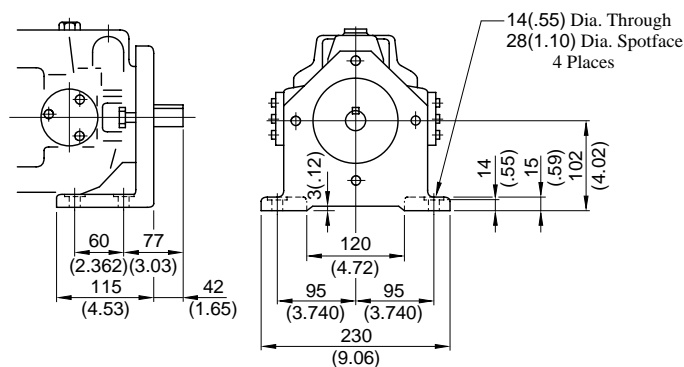

• For other dimensions, refer to "Flange Mtg."



Flange Mtg. : A56R1-FR01\*-\*AAK-32/3280/3290

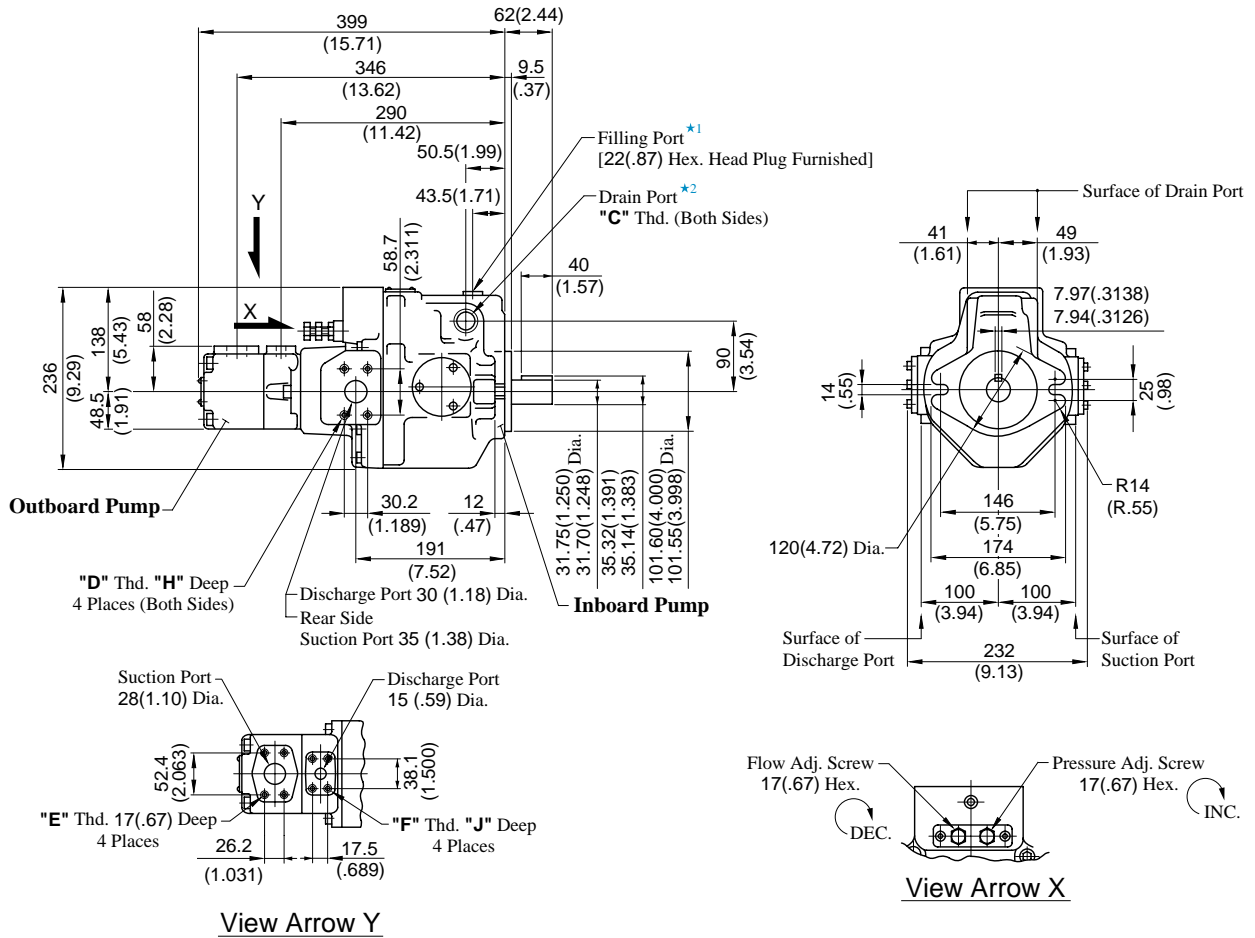

- ★ 1. Install the pump so that the "Filling Port" is at the top.
- ★ 2. Use either port of two drain ports of inboard pump at your option. Keep the remaining port plugged. Note that on the European design standard (3280 Design), only the left side, as viewed from the shaft end, of the drain port is machined.

Model Numbers	"C" Thd.	"D" Thd.	"E" Thd.	"F" Thd.	mm (IN.)	
					H	J
A56R1-FR01*-*AAK-32	Rc 3/4	M10	M10	M8	19 (.75)	14 (.55)
A56R1-FR01*-*AAK-3280	3/4 BSP.F				20 (.79)	16 (.63)

DIMENSIONS IN  
MILLIMETRES (INCHES)

Foot Mtg. : A56R1-LR01\*-\*AAK-32/3280/3290

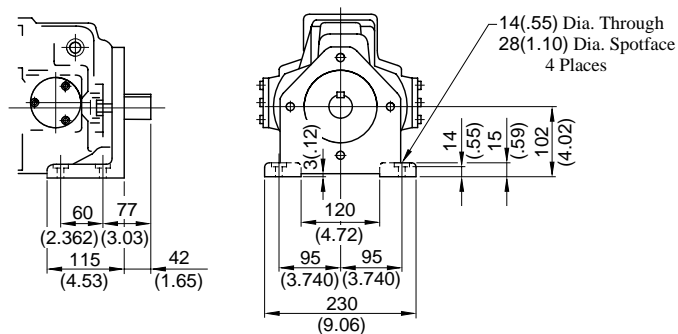

• For other dimensions, refer to "Flange Mtg.".

### Installation Drawing

Flange Mtg. : A70R1-FR01\*-\*AA-60/6080/6090  
A70R2-FR01\*-\*AA-60/6080/6090

DIMENSIONS IN  
MILLIMETRES (INCHES)

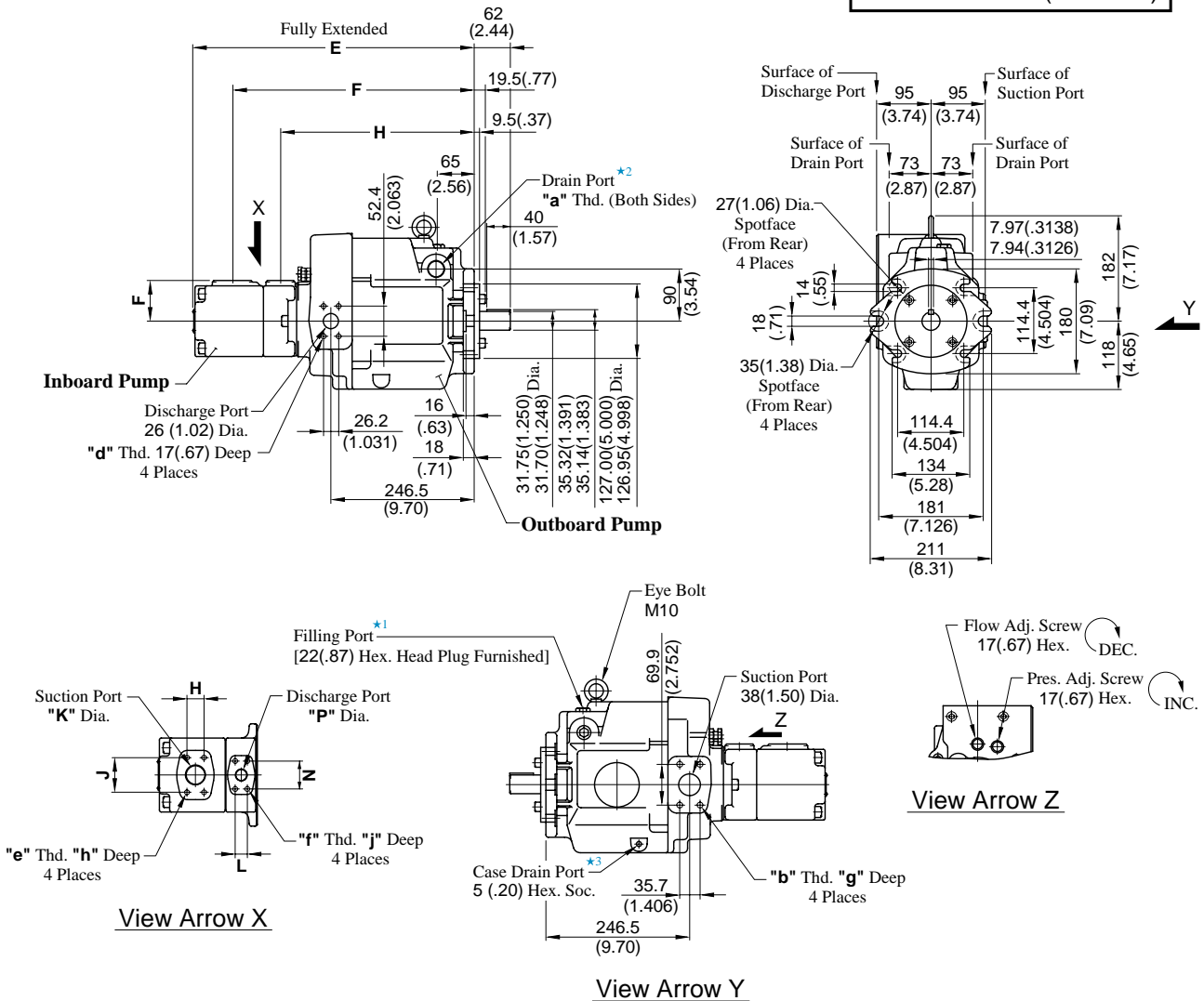

★ 1. Install the pump so that the "Filling Port" is at the top.

★ 2. Use either port of two drain ports of inboard pump at your option. Keep the remaining port plugged. Note that on the European design standard (6080 Design), only the left side, as viewed from the shaft end, of the drain ports is machined.

★ 3. Case drain ports are available for use when draining hydraulic fluid from pump casing.

Model Numbers	Dimensions mm (Inches)									
	C	D	E	F	H	J	K	L	N	P
A70R1-FR01*-*AA-60*	439.5 (17.30)	386.5 (15.22)	330.5 (13.01)	58 (2.28)	26.2 (1.031)	52.4 (2.063)	28 (1.10)	17.5 (0.689)	38.1 (1.500)	15 (0.59)
A70R2-FR01*-*AA-60*	468.5 (18.44)	413.5 (16.28)	333.5 (13.13)	70 (2.76)	30.2 (1.189)	58.7 (2.311)	34 (1.34)	22.2 (0.874)	47.6 (1.874)	21 (0.83)

Model Numbers	Thread Size					mm (Inches)				
	a	b	d	e	f	g	h	j		
A70R1-FR01*-*AA-60	Rc 3/4	M12	M10	M10	M8	19 (.75)	17 (.67)	14 (.55)		
A70R1-FR01*-*AA-6080	3/4 BSP.F							16 (.63)		
A70R1-FR01*-*AA-6090	3/4 NPT	1/2-13 UNC	3/8-16 UNC	3/8-16 UNC	5/16-18 UNC	21 (.83)				
A70R2-FR01*-*AA-60	Rc 3/4	M12	M10	M10	M10	19 (.75)	19 (.75)	17 (.67)		
A70R2-FR01*-*AA-6080	3/4 BSP.F									
A70R2-FR01*-*AA-6090	3/4 NPT	1/2-13 UNC	3/8-16 UNC	7/16-14 UNC	3/8-16 UNC	21 (.83)	20 (.79)			

### ● Foot Mounting Type

The mounting bracket is common to that of single pumps A70. Refer to page 21 for the dimensions of mounting bracket.

Flange Mtg. : A90R1-FR01\*-\*AA-60/6080/6090  
A90R2-FR01\*-\*AA-60/6080/6090

DIMENSIONS IN  
MILLIMETRES (INCHES)

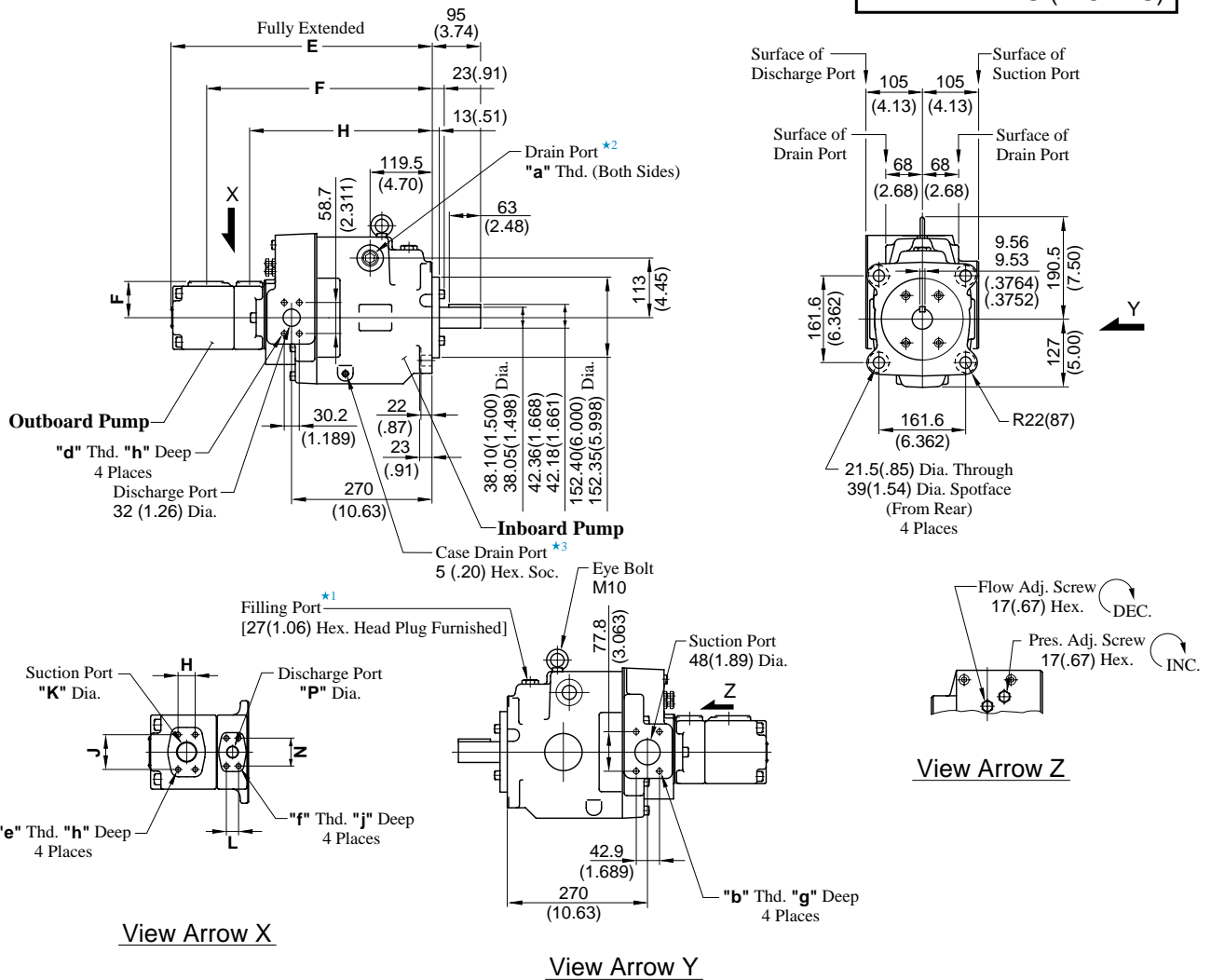

- ★ 1. Install the pump so that the "Filling Port" is at the top.
- ★ 2. Use either port of two drain ports of inboard pump at your option. Keep the remaining port plugged. Note that on the European design standard (6080 Design), only the left side, as viewed from the shaft end, of the drain ports is machined.
- ★ 3. Case drain ports are available for use when draining hydraulic fluid from pump casing.

Model Numbers	Dimensions mm (Inches)									
	C	D	E	F	H	J	K	L	N	P
A90R1-FR01*-*AA-60*	458 (18.03)	405 (15.94)	349 (13.74)	58 (2.28)	26.2 (1.031)	52.4 (2.063)	28 (1.10)	17.5 (.689)	38.1 (1.500)	15 (.59)
A90R2-FR01*-*AA-60*	497 (19.57)	432 (17.01)	352 (13.86)	70 (2.76)	30.2 (1.189)	58.7 (2.311)	34 (1.34)	22.2 (.874)	47.6 (1.874)	21 (.83)

Model Numbers	Thread Size						mm (Inches)			
	a	b	d	e	f	g	h	j		
A90R1-FR01*-*AA-60	Rc 3/4	M12	M10	M10	M8	19 (.75)	17 (.67)	14 (.55)		
A90R1-FR01*-*AA-6080	3/4 BSP.F							16 (.63)		
A90R1-FR01*-*AA-6090	3/4 NPT	1/2-13 UNC	7/16-14 UNC	3/8-16 UNC	5/16-18 UNC	21 (.83)				
A90R2-FR01*-*AA-60	Rc 3/4	M12	M10	M10	M10	19 (.75)	19 (.75)	17 (.67)		
A90R2-FR01*-*AA-6080	3/4 BSP.F									
A90R2-FR01*-*AA-6090	3/4 NPT	1/2-13 UNC	7/16-14 UNC	7/16-14 UNC	3/8-16 UNC	21 (.83)	20 (.79)			

#### ● Foot Mounting Type

The mounting bracket is common to that of single pumps A90. Refer to page 22 for the dimensions of mounting bracket.

### Installation Drawing

Flange Mtg. : A145R1-FR01\*-\*AA-60/6080/6090  
A145R2-FR01\*-\*AA-60/6080/6090

DIMENSIONS IN  
MILLIMETRES (INCHES)

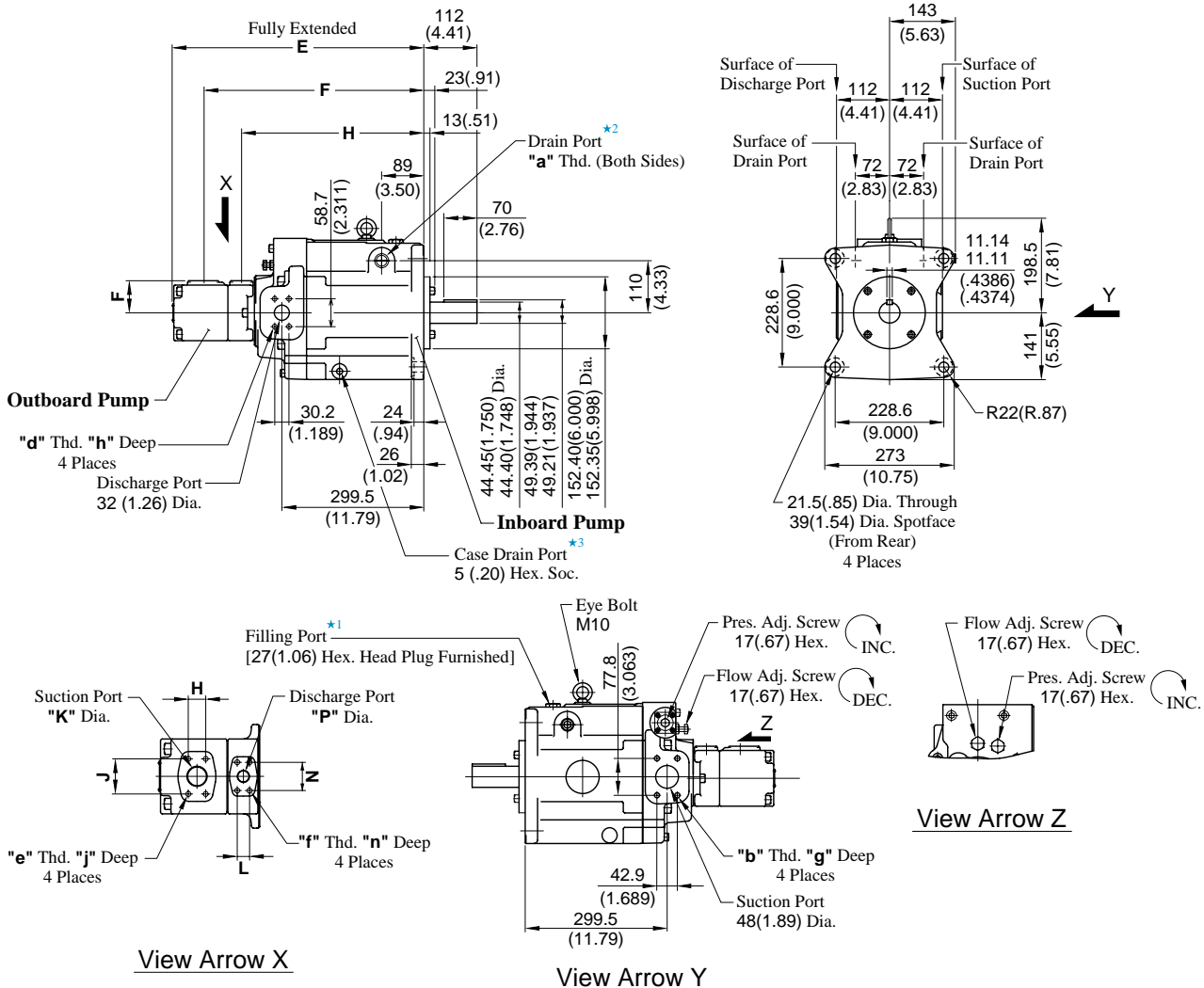

- ★ 1. Install the pump so that the "Filling Port" is at the top.
- ★ 2. Use either port of two drain ports of inboard pump at your option. Keep the remaining port plugged. Note that on the European design standard (6080 Design), only the left side, as viewed from the shaft end, of the drain ports is machined.
- ★ 3. Case drain ports are available for use when draining hydraulic fluid from pump casing.

Model Numbers	Dimensions mm (Inches)									
	C	D	E	F	H	J	K	L	N	P
A145R1-FR01*-*AA-60*	491.5 (19.35)	438.5 (17.26)	382.5 (15.06)	58 (2.28)	26.2 (1.031)	52.4 (2.063)	28 (1.10)	17.5 (.689)	38.1 (1.500)	15 (.59)
A145R2-FR01*-*AA-60*	530.5 (20.89)	465.5 (18.33)	385.5 (15.18)	70 (2.76)	30.2 (1.189)	58.7 (2.311)	34 (1.34)	22.2 (.874)	47.6 (1.874)	21 (.83)

Model Numbers	Thread Size					mm (Inches)				
	a	b	d	e	f	g	h	j	n	
A145R1-FR01*-*AA-60	Rc 3/4	M12	M10	M10	M8	19 (.75)	19 (.75)	17 (.67)	14 (.55)	
A145R1-FR01*-*AA-6080	3/4 BSP.F									
A145R1-FR01*-*AA-6090	3/4 NPT	1/2-13 UNC	7/16-14 UNC	3/8-16 UNC	5/16-18 UNC	21 (.83)	20 (.79)		16 (.63)	
A145R2-FR01*-*AA-60	Rc 3/4	M12	M10	M10	M10	19 (.75)	19 (.75)	19 (.75)	17 (.67)	
A145R2-FR01*-*AA-6080	3/4 BSP.F									
A145R2-FR01*-*AA-6090	3/4 NPT	1/2-13 UNC	7/16-14 UNC	7/16-14 UNC	3/8-16 UNC	21 (.83)	20 (.79)	20 (.79)		

#### ● Foot Mounting Type

The mounting bracket is common to that of single pumps A145. Refer to page 23 for the dimensions of mounting bracket.

A16R1-\*R01\*-\*AAK-32/3280/3290  
 A22R1-\*R01\*-\*AAK-32/3280/3290  
 A37R1-\*R01\*-\*AAK-32/3280/3290  
 A56R1-\*R01\*-\*AAK-32/3280/3290  
 A70R1/A70R02-\*R01\*-\*AA-60/6080/6090  
 A90R1/A90R02-\*R01\*-\*AA-60/6080/6090  
 A145R1/A145R02-\*R01\*-\*AA-60/6080/6090

### CAUTION

When making replacement of seals bearings or cartridge kits, please do it carefully after reading through the relevant instructions in the Operator's Manual.

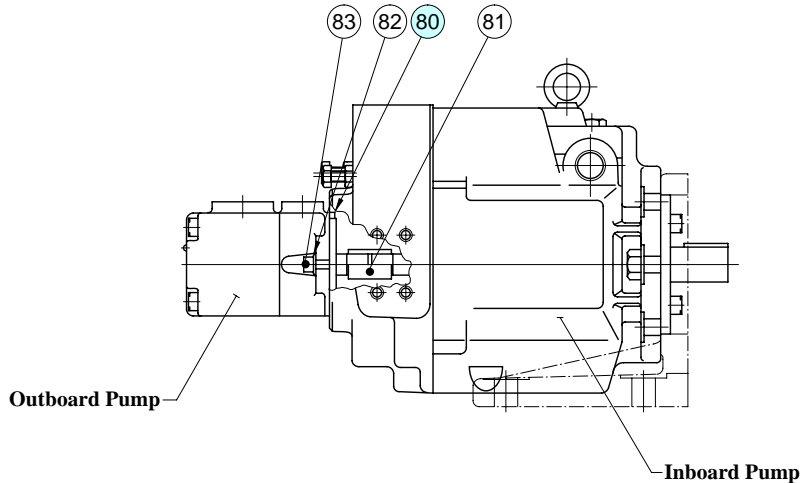

### ● Seals

Pump Model Numbers	Seal Kit Numbers			Part Numbers (Item 80 O-Ring)
	Complete Kit	For Inboard Pump	For Outboard Pump	
A16R1-*R01*-*AAK-32/3280/3290	KS-A16R1-01-32	KS-A16-01-32	KS-PV2R1-4010	S85(NBR,Hs70) 1Req'd
A22R1-*R01*-*AAK-32/3280/3290	KS-A22R1-01-32	KS-A22-01-32		
A37R1-*R01*-*AAK-32/3280/3290	KS-A37R1-01-32	KS-A37-01-32		
A56R1-*R01*-*AAK-32/3280/3290	KS-A56R1-01-32	KS-A56-01-32		
A70R1-*R01*-*AA-60/6080/6090	KS-A70R1-01-60	KS-A70-01-60		
A90R1-*R01*-*AA-60/6080/6090	KS-A90R1-01-60	KS-A90-01-60		
A145R1-*R01*-*AA-60/6080/6090	KS-A145R1-01-60	KS-A145-01-60		
A70R2-*R01*-*AA-60/6080/6090	KS-A70R2-01-60	KS-A70-01-60	KS-PV2R2-40	S105(NBR,Hs70) 1Req'd
A90R2-*R01*-*AA-60/6080/6090	KS-A90R2-01-60	KS-A90-01-60		
A145R2-*R01*-*AA-60/6080/6090	KS-A145R2-01-60	KS-A145-01-60		

Notes: 1) When ordering seals, please specify the seal kit number from the table above.

2) Complete seal kit consists of a seal kit for inboard pump, a seal kit for outboard pump and a piece of O-ring for item 80.

3) Seal kit and bearings for inboard pump are same as those for "A" series single pump. For details, please refer to the table below and see the chart on the page relevant to pump model number concerned.

4) For details of seals and bearing for outboard pump, please see the chart on the following page.

Model	Inboard Pump
A16R1	Same as single pump "A16" (Page 25)
A22R1	Same as single pump "A22" (Page 25)
A37R1	Same as single pump "A37" (Page 25)
A56R1	Same as single pump "A56" (Page 25)
A70R1/A70R2	Same as single pump "A70" (Page 26)
A90R1/A90R2	Same as single pump "A90" (Page 26)
A145R1/A145R2	Same as single pump "A145" (Page 27)

### Spare Parts List

#### ● Detail of Outboard Pump

A\*R1

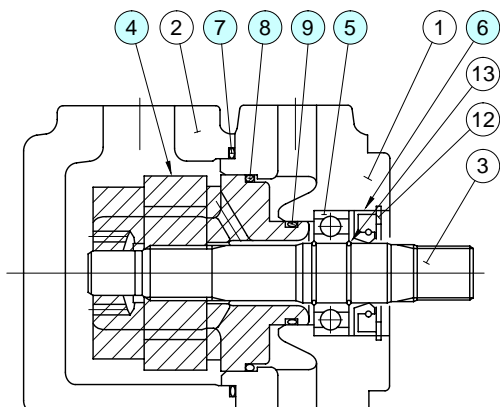

A\*R2

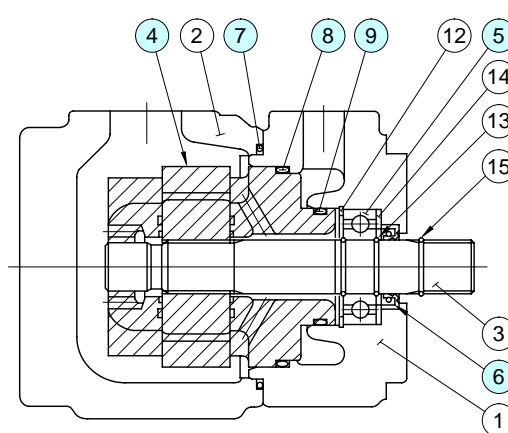

#### ● Sales & Bearing

Item	Name of Parts	Part Numbers		Qty.
		A*R1	A*R2	
5	Bearing	6004	6205	1
6*	Oil Seal	SB 20428	ISD 30428	1
7*	O-Ring	SO-NB-G80	SO-NB-G105	1
8*	O-Ring	SO-NB-G60	SO-NA-G85	1
9*	O-Ring	SO-NB-G30	SO-NA-P46	1

Note: Item Nos. ⑧ and ⑨ (O-rings) are included in the cartridge kit.

★ When ordering seals as described in the table above, please specify the seal kit number referring to chart on the previous page.

#### ● Cartridge Kits

Model Numbers	④ Cartridge Kit Numbers
A*R1-*R01*-6AAK-32*/60*	CPV2R1-6-R-40
A*R1-*R01*-8AAK-32*/60*	CPV2R1-8-R-40
A*R1-*R01*-10AAK-32*/60*	CPV2R1-10-R-40
A*R1-*R01*-12AAK-32*/60*	CPV2R1-12-R-40
A*R1-*R01*-14AAK-32*/60*	CPV2R1-14-R-40
A*R1-*R01*-17AAK-32*/60*	CPV2R1-17-R-40
A*R1-*R01*-19AAK-32*/60*	CPV2R1-19-R-40
A*R1-*R01*-23AAK-32*/60*	CPV2R1-23-R-40
A*R1-*R01*-25AAK-32*/60*	CPV2R1-25-R-40
A*R1-*R01*-31AAK-32*/60*	CPV2R1-31-R-40
<hr/>	
A*R2-*R01*-26AA-60*	CPV2R2-26-R-40
A*R2-*R01*-33AA-60*	CPV2R2-33-R-40
A*R2-*R01*-41AA-60*	CPV2R2-41-R-40
A*R2-*R01*-47AA-60*	CPV2R2-47-R-40
A*R2-*R01*-53AA-60*	CPV2R2-53-R-40
A*R2-*R01*-59AA-60*	CPV2R2-59-R-40
A*R2-*R01*-65AA-60*	CPV2R2-65-R-40

#### ⚠ CAUTION

When making replacement of seals, bearings or cartridge kits, please do it carefully after reading through the relevant instructions in the Operator's Manual.



**"AH" SERIES PISTON PUMPS**  
**Variable Displacement-Single Pumps**  
**Pressure Compensator Type**  
**AH 16 / AH 37 / AH 56**

**PISTON PUMPS**

**A**

**Up to 31 MPa (4500 PSI), 56.2 cm<sup>3</sup>/rev (3.43 CU.IN./rev)**

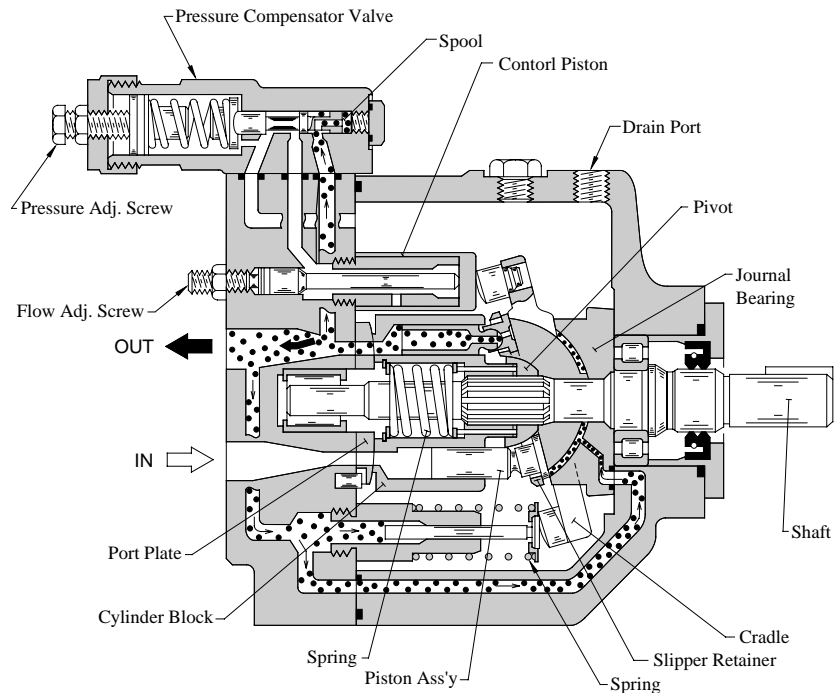

**Features**

**● Port Plate**

A special shape maintains a high volumetric efficiency under high pressure and provides greater durability.

**● Cradle Support Bearing**

Compared with conventional bearings, this bearing has strengthened rigidity of the swash plate. Noise level has much lowered because it is supported by a housing.

"AH16" type performance characteristics

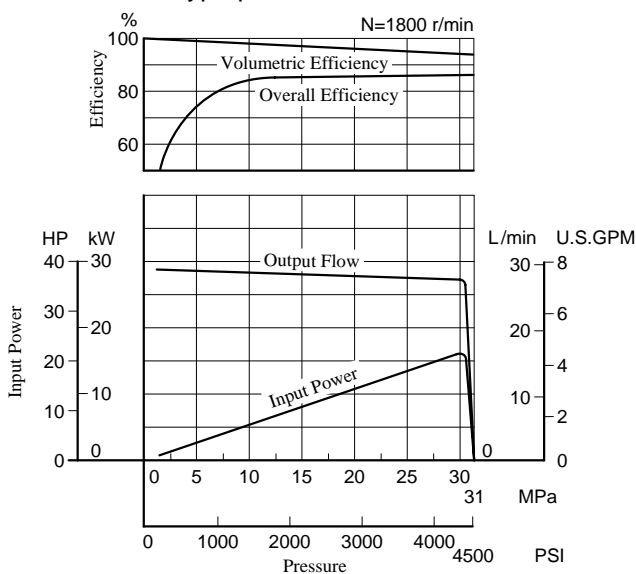

"AH16" type noise level characteristics

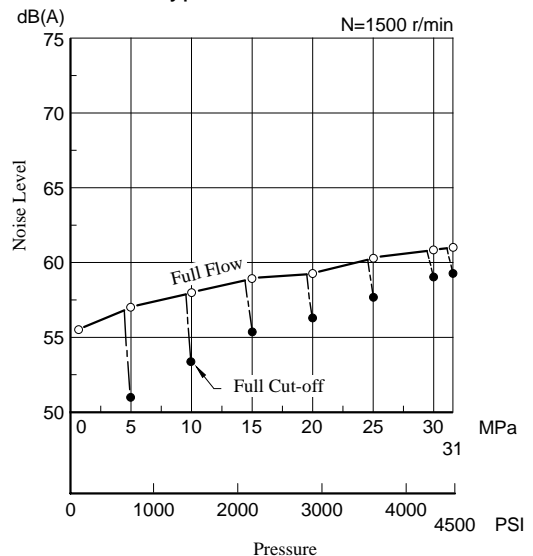

**● High Pressure**

Max. Operating Pres. 31 MPa (4500 PSI)

**● High speed**

Max. 3600 r/min (AH 16)

### Instructions

#### 1. Hydraulic Fluids

Use petroleum base oils such as anti-wear type hydraulic oils or R & O (Rust and Oxidation inhibitor) type hydraulic oils equivalent to ISO VG-32 or 46.

The recommended viscosity range is from 20 to 400 mm<sup>2</sup>/s (98 to 1800 SSU) and temperature range is from 0 to 60°C (32 to 140°F), both of which have to be satisfied for the use of the above hydraulic oils.

#### 2. Control of Contamination

Due caution must be paid to maintaining control over contamination of the operating oil which can otherwise lead to breakdowns and shorten the life of the unit. Please maintain the degree of contamination within NAS Grade 10.

The suction port must be equipped with at least a 100 μm (150 mesh) reservoir type filter and the return line must have a line filter of under 10 μm.

#### 3. Mounting

When installing the pump the filling port should be positioned upwards.

#### 4. Alignment of Shaft

Employ a flexible coupling whenever possible, and avoid any stress from bending or thrust.

Maximum permissible misalignment is less than 0.1 mm (.0039 inches) TIR and maximum permissible misangular is less than 0.2°.

#### 5. Suction Pressure

Permissible suction pressure at suction port of the pump is between -16.7 and +50 kPa (5 in.Hg Vacuum and 7 PSIG). In case of the speed is over 1800 r/min, adjust the pressure 0 to +50 kPa (0 to 7 PSIG).

For piping to the suction port, use the pipes of the same diameter as that of the specified pipe flange to be used.

Make sure that the height of the pump suction port is within one metre (3.3ft.) from the oil level in the reservoir.

#### 6. Hints on Piping

When using steel pipes for the suction or discharge ports, excessive load from the piping to the pump generates excessive noise.

Whenever there is fear of excessive load, please use rubber hoses.

#### 7. Suction Piping

In case the pump is installed above the oil level, the suction piping and suction line filter should be located lower than the pump position to prevent air in the suction line.

#### 8. Drain Piping

Install drain piping according to the chart and ensure that pressure within the pump housing should be maintained at a normal pressure of less than 0.1 MPa (15 PSI) and surge pressure of less than 0.5 MPa (70 PSI).

Length of piping should be less than 1 m (3.3 ft.), and the pipe end should be submerged in oil.

[Recommended Drain Piping Size]

Model	Fitting Size	Inside Dia. of pipe
AH16 AH37	1/2 [Inside Dia. 12 mm (.47 in.) or more]	12 mm (.47 in.)
AH56	3/4 [Inside Dia. 16 mm (.63 in.) or more]	19 mm (.75 in.)

#### 9. Bleeding Air

It may be necessary to bleed air from pump case and outlet line to remove causes of vibration. An air bleed valve (Model No. ST1004-\* -10\*, Catalogue No.: Pub. EC-3001) is recommended for this purpose.

#### 10. Starting

Before first starting, fill pump case with clean operating oil via the fill port.

In order to avoid air blockage when first starting, adjust the control valves so that the discharged oil from the pump is returned direct to the tank or the actuator moves in a free load.

[Volume of Pre-fill Oil Required]

Model	Volume cm <sup>3</sup> (in. <sup>3</sup> )
AH16	600 (36.6)
AH37	1100 (67.1)
AH56	1500 (91.5)



## 11. Setting Discharge Pressure and Delivery

At the time of shipment, the unit has been preset to maximum delivery and minimum discharge pressure.

Adjust the preset delivery and pressure to meet your system requirements.

### ● Adjustment of Discharge Pressure

Turning the adjustment screw clockwise, increases pressure.

[ Volume adjusted by each full turn of the pressure adjustment screw ]

Model Numbers	Adjustment Volume MPa (PSI)
AH16/AH37/AH56	5.4 (780)

### ● Adjustment of Delivery

Turning the flow adjustment screw clockwise, decreases delivery.

[ The minimum adjustable flow and adjustable volume of each full turn of the delivery adjustment screw ]

Model Numbers	Adjustable volume with each full turn of the adjustment screw cm <sup>3</sup> /rev (cu.in./rev)	Minimum adjustable flow cm <sup>3</sup> /rev (cu.in./rev)
AH16	1.4 (.085)	8 (.488)
AH37	3.0 (.183)	14 (.854)
AH56	3.5 (.214)	35 (2.14)



Graphic Symbol

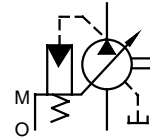

### Specifications

Model Numbers	Geometric Displacement cm <sup>3</sup> /rev (cu. in./rev)	Minimum Adj. Flow cm <sup>3</sup> /rev (cu. in./rev)	Operating Pres. MPa (PSI)		Shaft Speed Range r/min		Approx. Mass kg (lbs.)	
			Rated <sup>*</sup>	Intermittent	Max.	Min.	Flang Mtg.	Foot Mtg.
AH16- <i>*R01K*-10*</i>	16.0 (.976)	8.0 (.488)	25 (3630)	31 (4500)	3600	600	18.8 (41.5)	23.8 (52.5)
AH37- <i>*R01K*-20*</i>	37.0 (2.26)	14.0 (.854)			2800	600	26.0 (57.3)	35.0 (77.2)
AH56- <i>*R01K*-11*</i>	56.2 (3.43)	35.0 (2.14)			2500	600	42.0 (92.6)	50.9 (112)

★ Consult Yuken when pump is used over rated pressure because there is a restriction on operating condition.

### Model Number Designation

AH16	-F	R	01	K	K	-10	*
Series Number	Mounting	Direction of Rotation	Control Type	Pres Adj. Range MPa (PSI)	Shaft <sup>*1</sup> Extension	Design Number	Design Std.
AH16 (16.0 cm <sup>3</sup> /rev)	F: Flange Mtg.  L: Foot Mtg.	[Viewed from Shaft End]  R: Clockwise (Normal)	01: Pressure Compensator Type	K: 5 - 31 (730 - 4500)	K: Keyed Shaft	10	Refer to <sup>*2</sup>
AH37 (37.0 cm <sup>3</sup> /rev)						20	
AH56 (56.2 cm <sup>3</sup> /rev)						11	

★1. We can also supply spline-type shaft extension. Please consult us for details.

★2. Design Standards: None ... Japanese Standard "JIS"  
80 ..... European Design Standard  
90 ..... N. American Design Standard

### Pipe Flange Kits

Pipe flange kits are available. When ordering, specify the kit number from the table below.

Pump Model Numbers	Name of Port	Pipe Flange Kit Numbers						
		Thread Connection			Socket Welding		Butt Welding	
		Japanese Standard "JIS"	European Design Standard	N. American Design Standard	Japanese standard "JIS" European Design Standard	N. American Design Standard	Japanese Standard "JIS" European Design Standard	N. American Design Standard
AH16	Suction	F5-08-A-10	F5-08-A-1080	F5-08-A-1090	F5-08-B-10	F5-08-B-1090	F5-08-C-10	F5-08-C-1090
	Discharge	F6-06-A-M-10	F6-06-A-M-1080	F6-06-A-U-1090	F6-06-B-M-10	F6-06-B-U-1090	—	—
AH37	Suction	F5-12-A-10	F5-12-A-1080	F5-12-A-1090	F5-12-B-10	F5-12-B-1090	F5-12-C-10	F5-12-C-1090
	Discharge	F6-10-A-M-10	F6-10-A-M-1080	F6-10-A-U-1090	F6-10-B-M-10	F6-10-B-U-1090	—	—
AH56	Suction	F5-16-A-10	F5-16-A-1080	F5-16-A-1090	F5-16-B-10	F5-16-B-1090	F5-16-C-10	F5-16-C-1090
	Discharge	F6-10-A-M-10 or F6-10W-A-M-10	F6-10-A-M-1080 or F6-10W-A-M-1080	F6-10-A-U-1090 or F6-10W-A-U-1090	F6-10-B-M-10 or F6-10W-B-M-10	F6-10-B-U-1090 or F6-10W-B-U-1090	—	—

● Detail of the pipe flange kits are given in the Catalogue No. Pub. EC-3001.

**Response Characteristics**

■ Response Characteristics

Response Characteristics Change in Accordance with Circuits and Operating Conditions.

● Test Circuit and Conditions

● Circuit

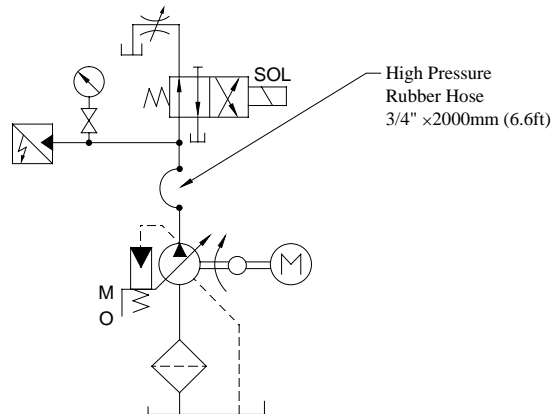

● Conditions

Drive Speed: 1500 r/min  
 Hydraulic Fluid: ISO VG32 Oil  
 Oil Temperature: 40°C (104°F) [Viscosity 32 mm<sup>2</sup>/s (150 SSU)]

● Result of Measurement

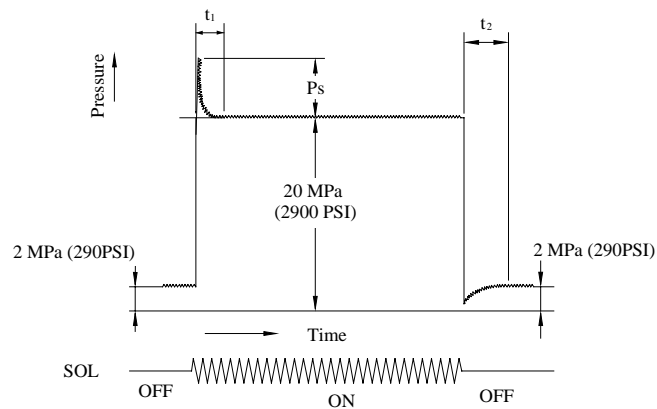

Model	Response Time ms		Ps Overshoot Pres. MPa (PSI)
	t <sub>1</sub>	t <sub>2</sub>	
AH16	50	95	2.5 (360)
AH37	60	150	5.1 (740)
AH56	60	115	8.3 (1200)

Typical Performance Characteristics of Type "AH16" at Viscosity 32 mm<sup>2</sup>/s (150 SSU) [ISO VG32 Oils, 40°C (104°F)]

#### ■ Performance Characteristic Curve

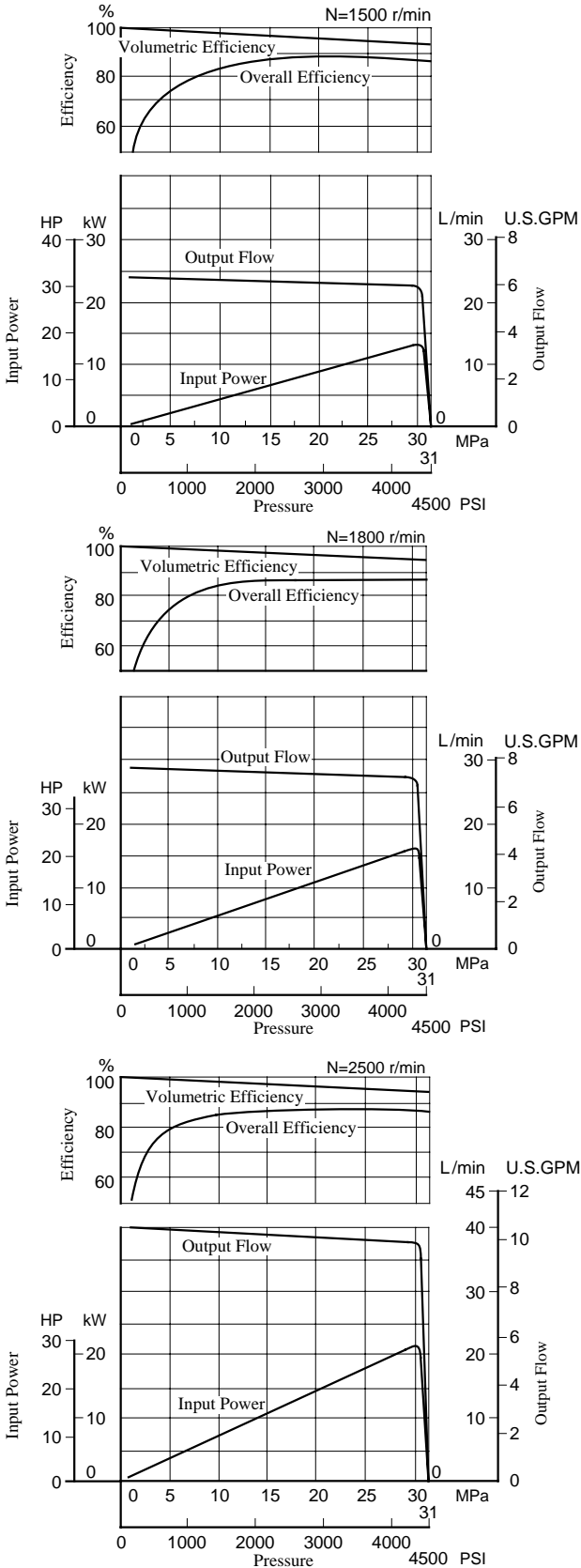

#### ■ Input Power

Example: At a pressure of under 30 MPa (4350 PSI), a flow 15 L/min (4.0 U.S.GPM), and rotation 1500 r/min, the axial input becomes about 9 kW (12 HP) as shown the dotted line in the graph.

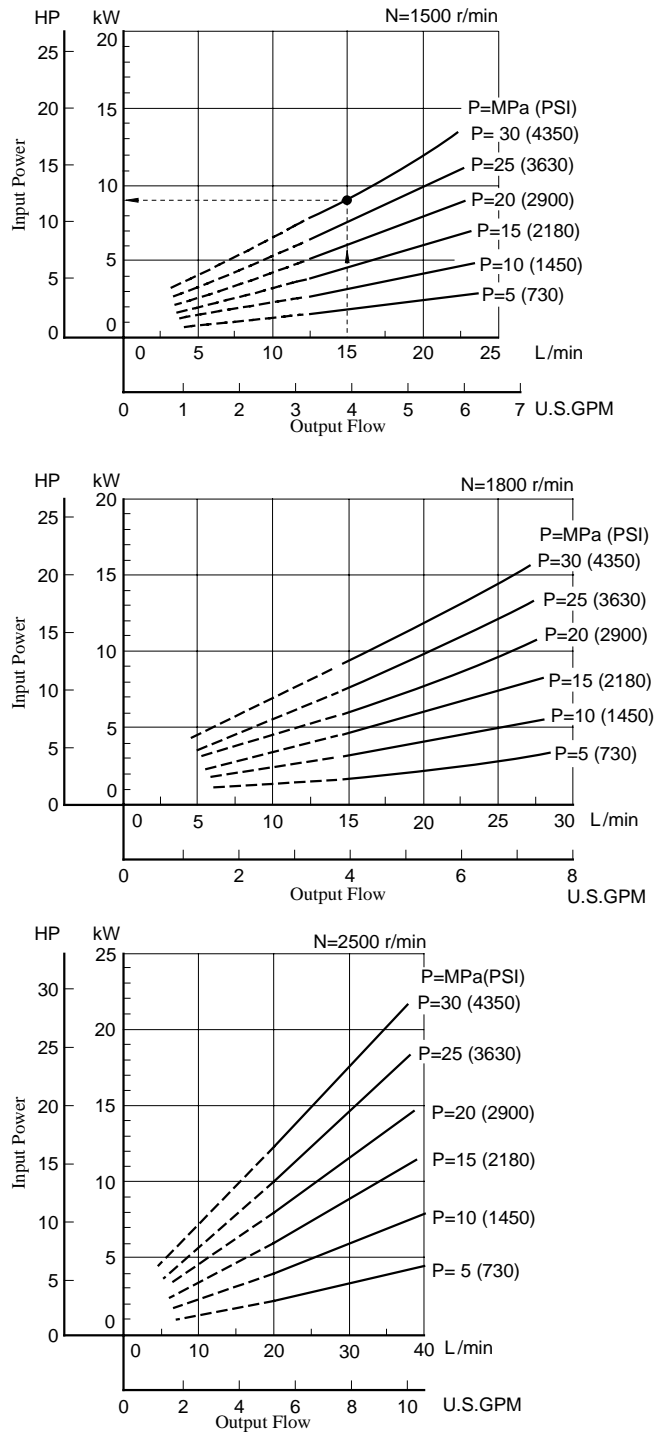

Note) The dotted line in the graph indicates less than minimum adjustable flow.

Typical Performance Characteristics of Type "AH16" at Viscosity 32 mm<sup>2</sup>/s (150 SSU) [ISO VG32 Oils, 40°C (104°F)]

#### ■ Noise Level

[One metre (3.3 ft.) horizontally away from pump head cover]

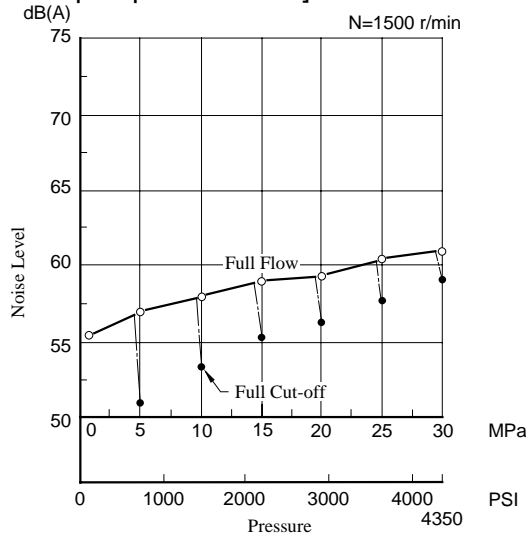

#### ■ Full Cut-off Power

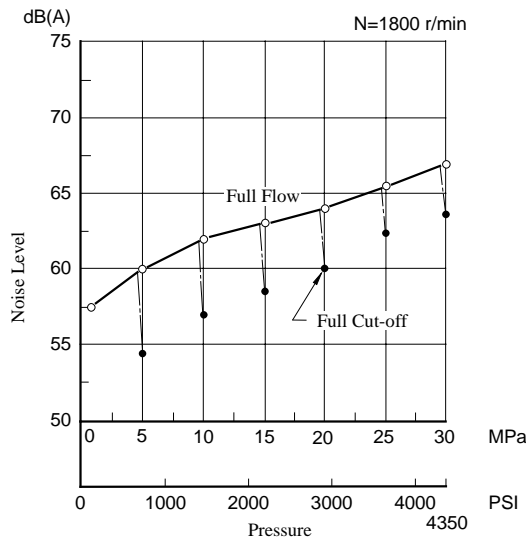
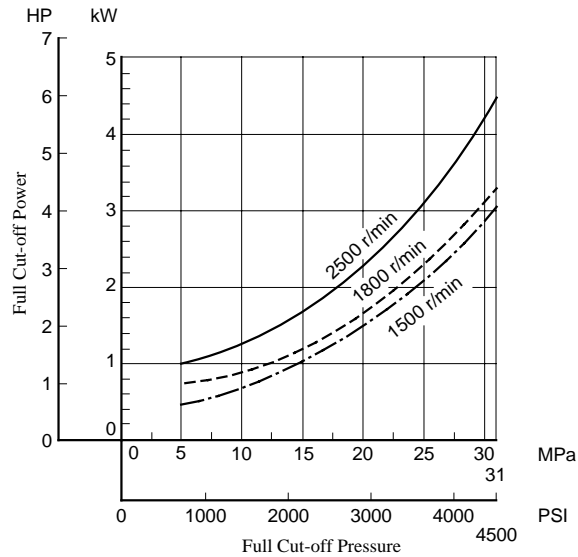

#### ■ Drain

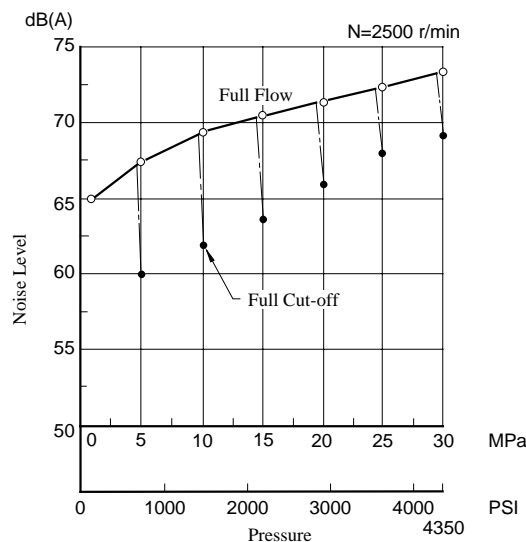
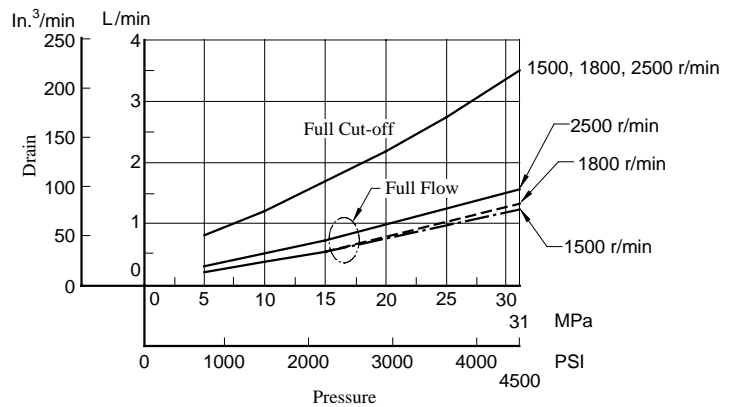

Typical Performance Characteristics of Type "AH37" at Viscosity 32 mm<sup>2</sup>/s (150 SSU) [ISO VG32 Oils, 40°C (104°F)]

#### Performance Characteristic Curve

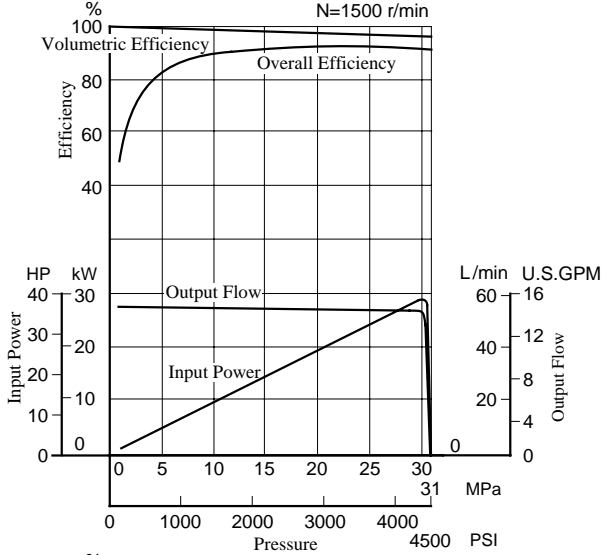

#### Input Power

Example: At a pressure of under 30 MPa (4350 PSI), a flow 35 L/min (9.2 U.S.GPM), and rotation 1500 r/min, the axial input becomes about 19 kW (25.5 HP) as shown the dotted line in the graph.

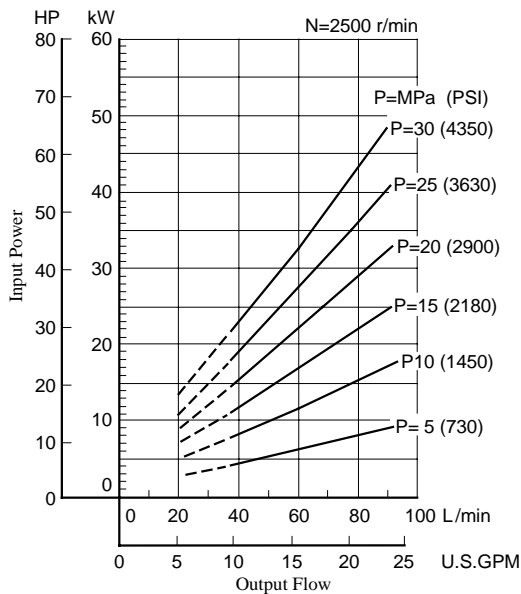
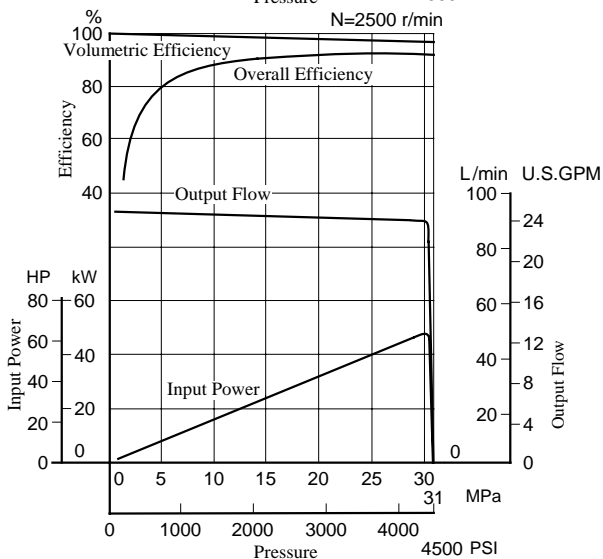
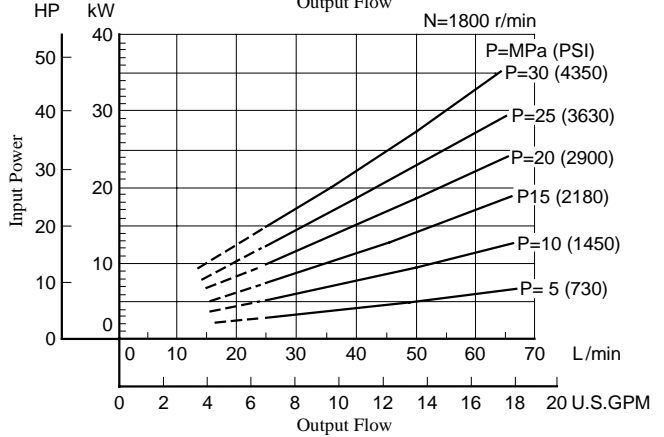
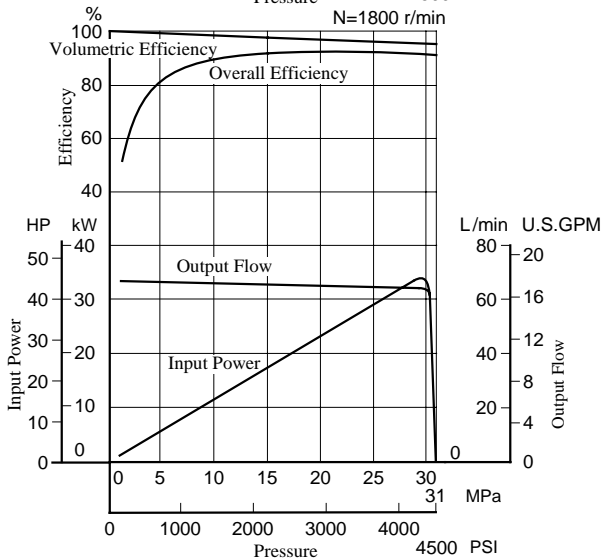
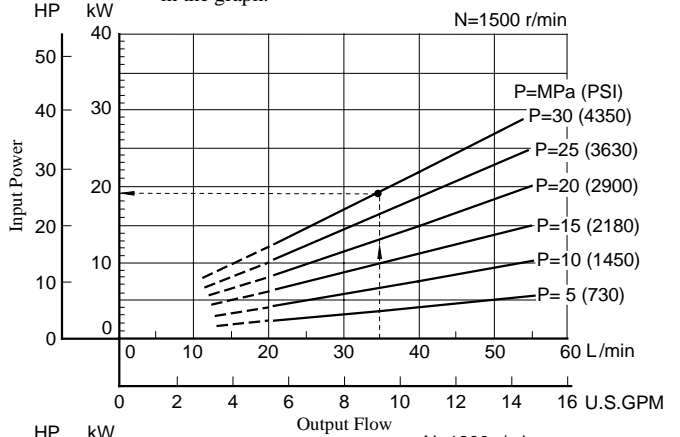

Note) The dotted line in the graph indicates less than minimum adjustable flow.

### Typical Pump Characteristics

Typical Performance Characteristics of Type "AH37" at Viscosity 32 mm<sup>2</sup>/s (150 SSU) [ISO VG32 Oils, 40°C (104°F)]

#### ■ Noise Level

[One metre (3.3 ft.) horizontally away from pump head cover]

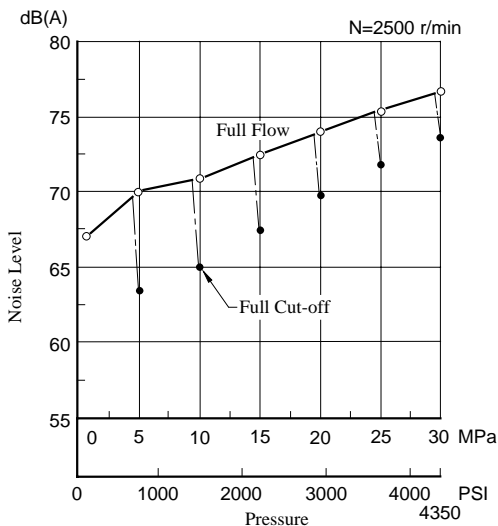
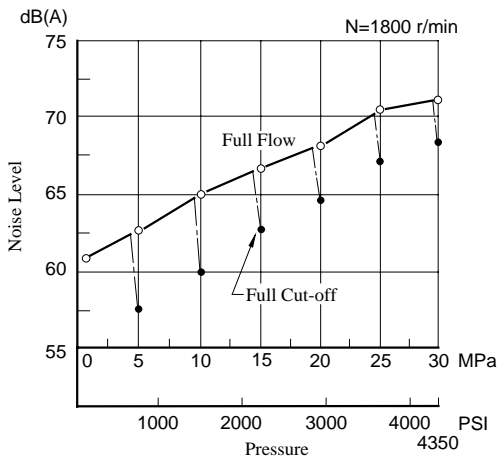
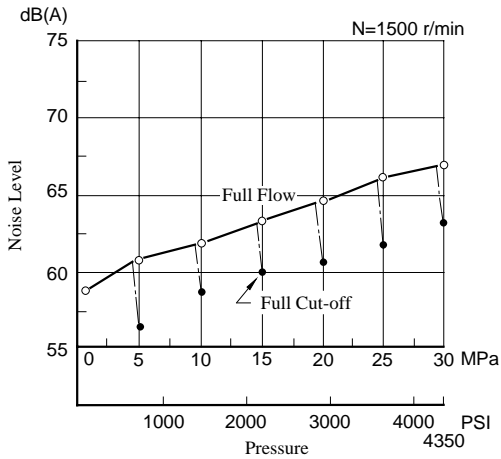

#### ■ Full Cut-off Power

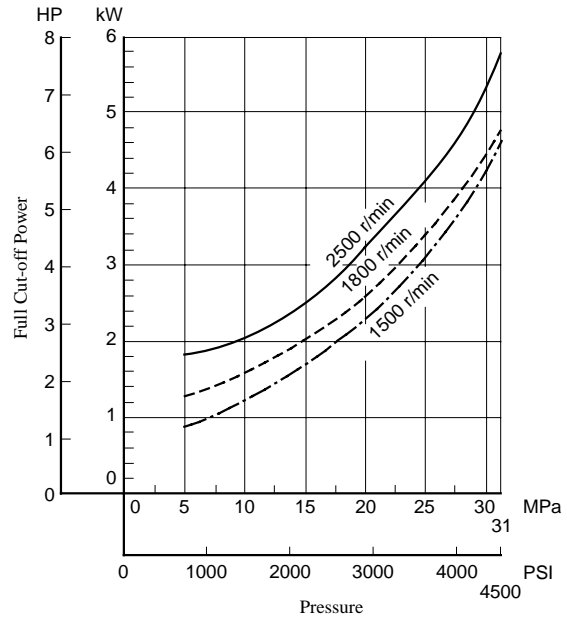

#### ■ Drain

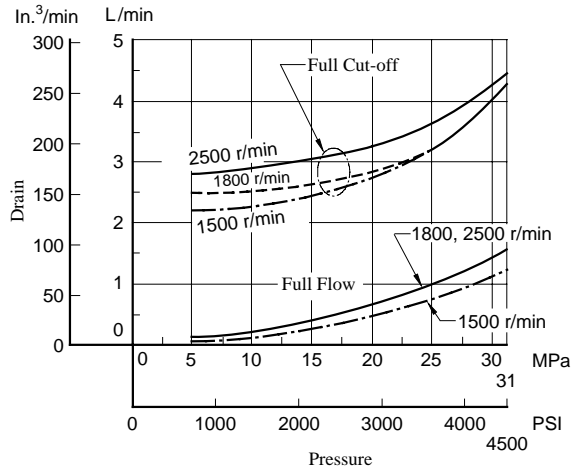

Typical Performance Characteristics of Type "AH56" at Viscosity 32 mm<sup>2</sup>/s (150 SSU) [ISO VG32 Oils, 40°C (104°F)]

#### Performance Characteristic Curve

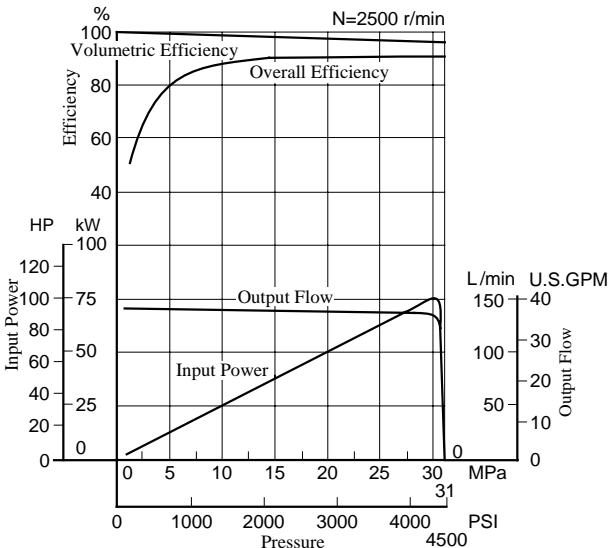
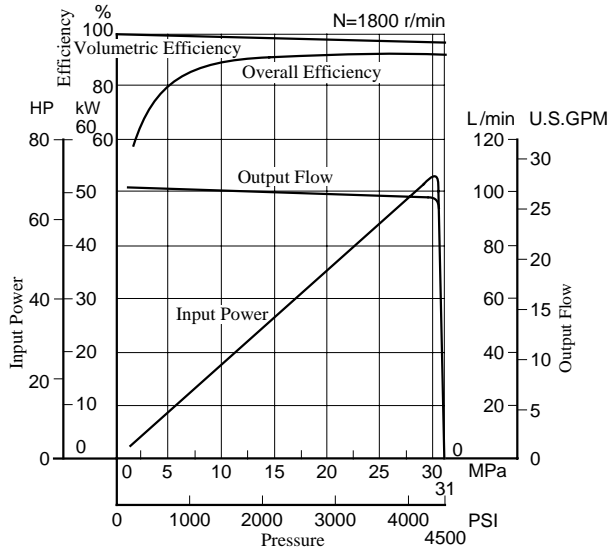
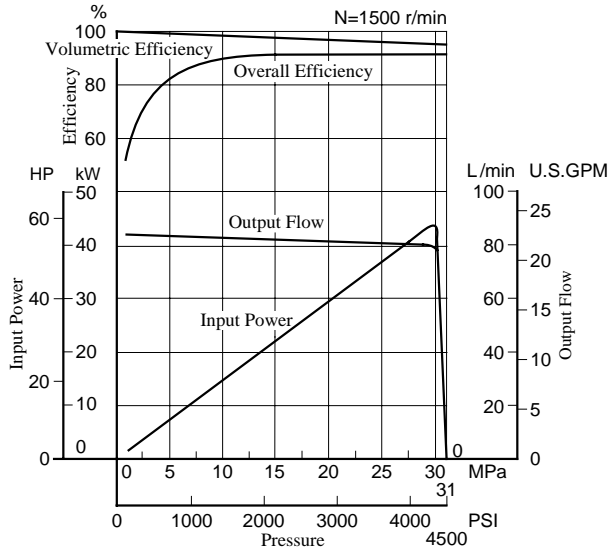

#### Input Power

Example: At a pressure of under 30 MPa (4350 PSI), a flow 65 L/min ( 17.2 U.S.GPM), and rotation 1500 r/min, the axial input becomes about 36 kW (48 HP) as shown the dotted line in the graph.

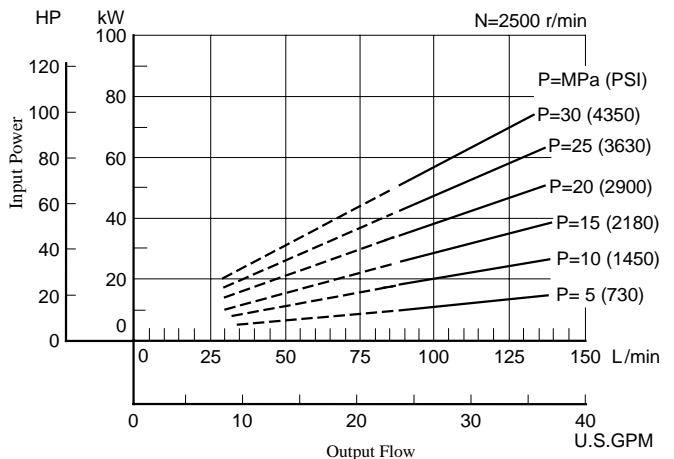
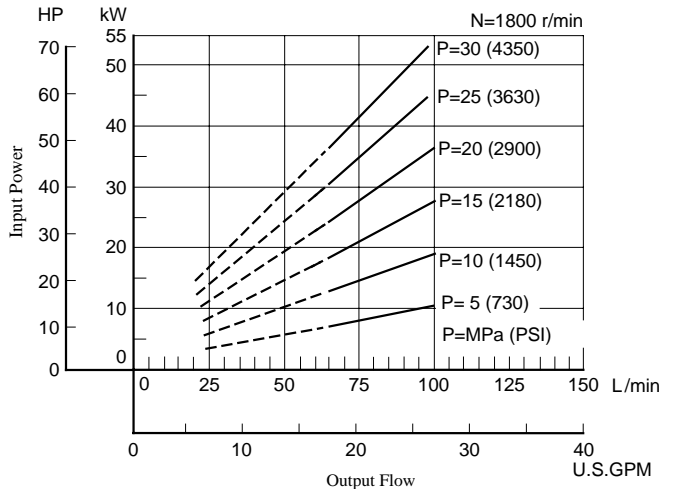
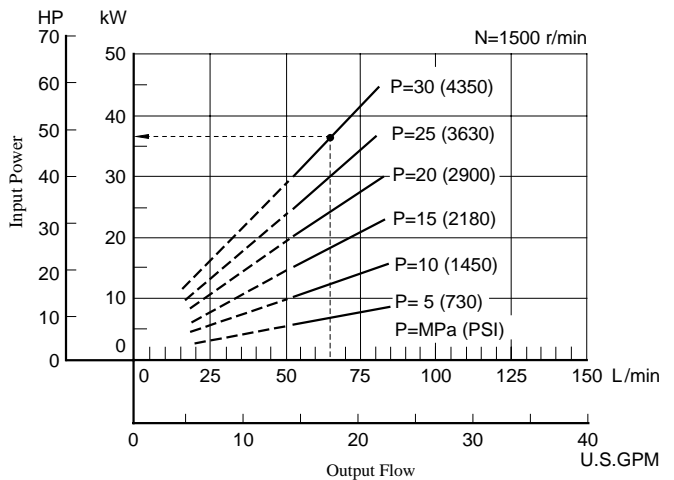

Note) The dotted line in the graph indicates less than minimum adjustable flow.



### Typical Pump Characteristics

Typical Performance Characteristics of Type "AH56" at Viscosity 32 mm<sup>2</sup>/s (150 SSU) [ISO VG32 Oils, 40°C (104°F)]

#### ■ Noise Level

[One metre (3.3 ft.) horizontally away from pump head cover]

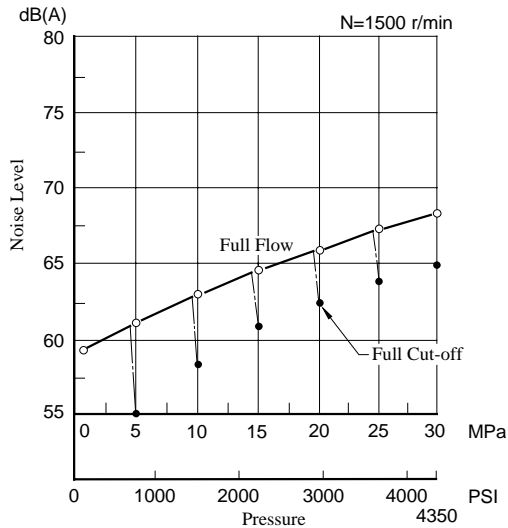

#### ■ Full Cut-off Power

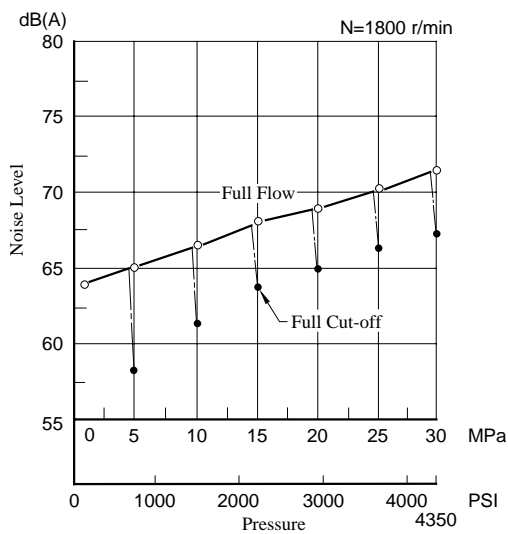
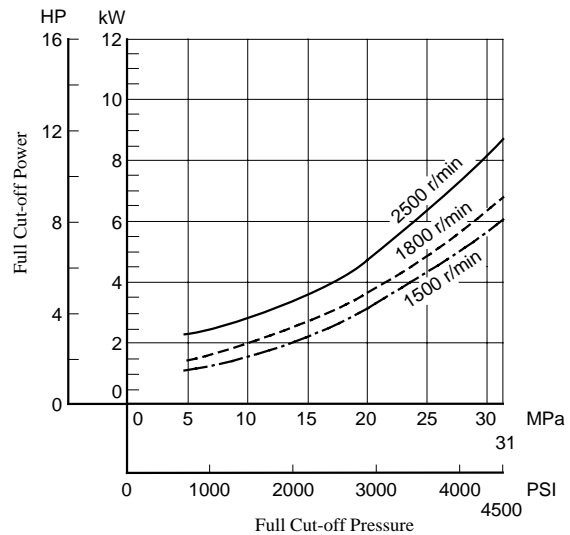

#### ■ Drain

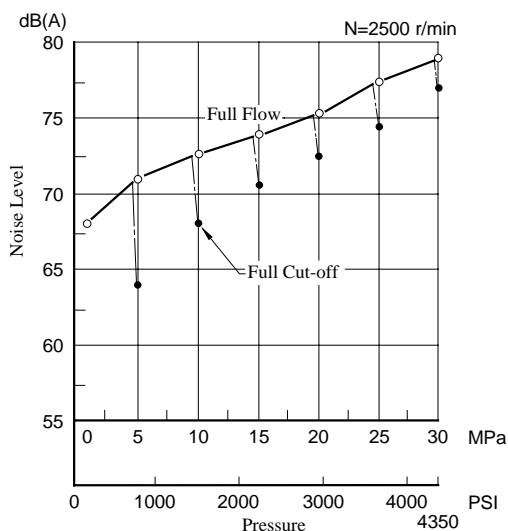
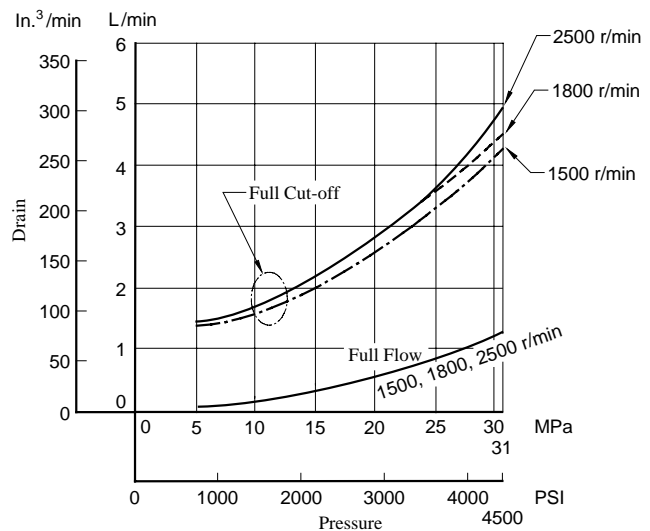

Flange Mtg.: AH16-FR01KK-10/1080/1090

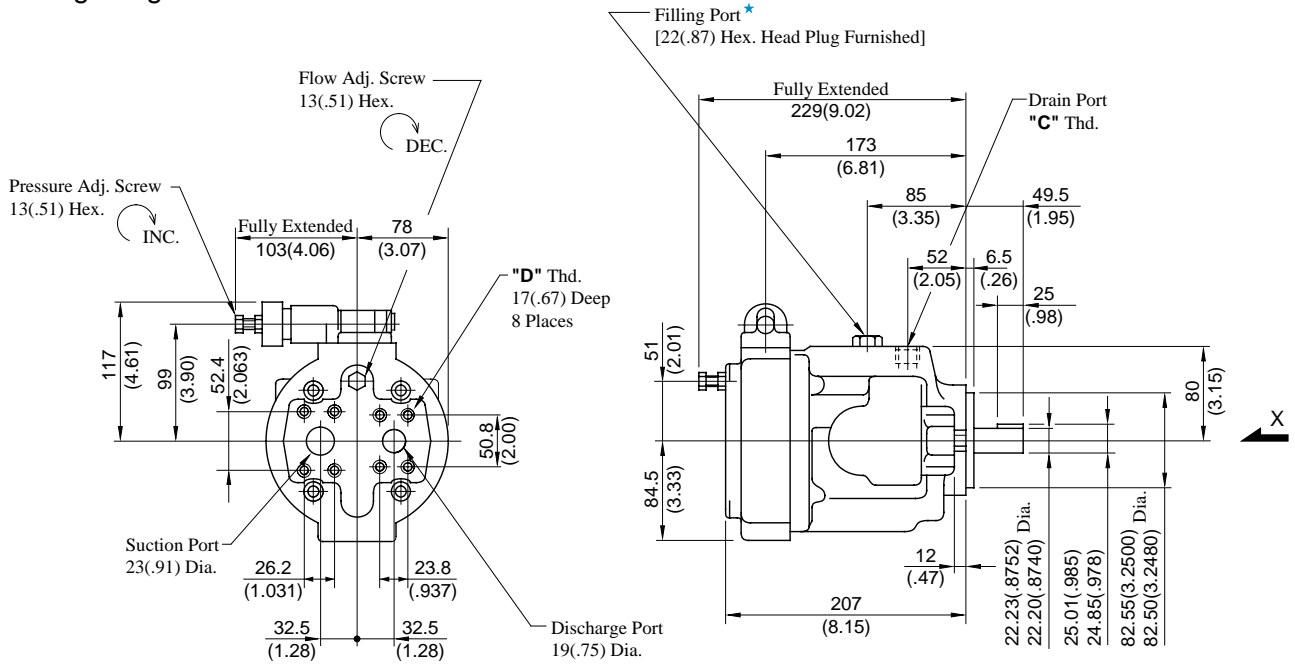

★ Install the pump so that the "Filling port" is at the top.

Model Numbers	"C" Thd.	"D" Thd.
AH16-FR01KK-10	Rc 1/2	M10
AH16-FR01KK-1080	1/2 BSP.F	
AH16-FR01KK-1090	1/2 NPT	3/8-16 UNC

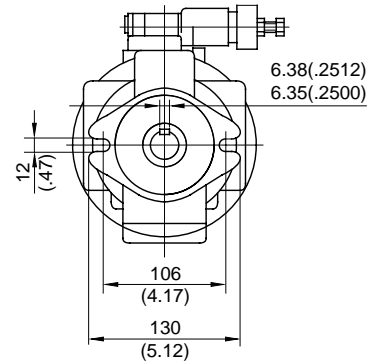

View Arrow X

DIMENSIONS IN  
MILLIMETRES (INCHES)

Foot Mtg.: AH16-LR01KK-10/1080/1090

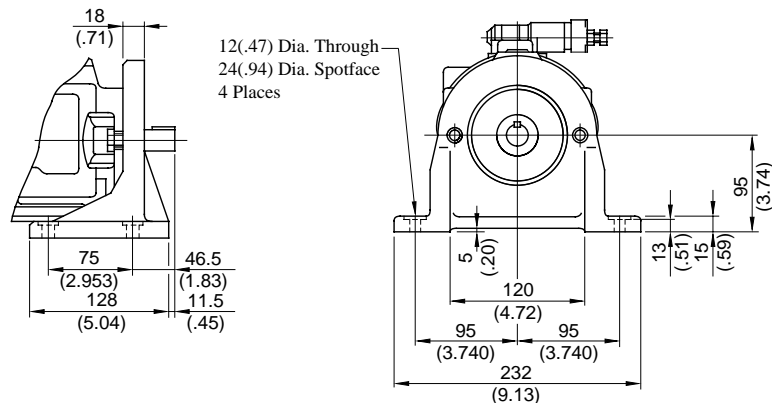

● For other dimensions, refer to "Flange Mtg.".

### Installation Drawing

Flange Mtg.: AH37-FR01KK-20/2080/2090

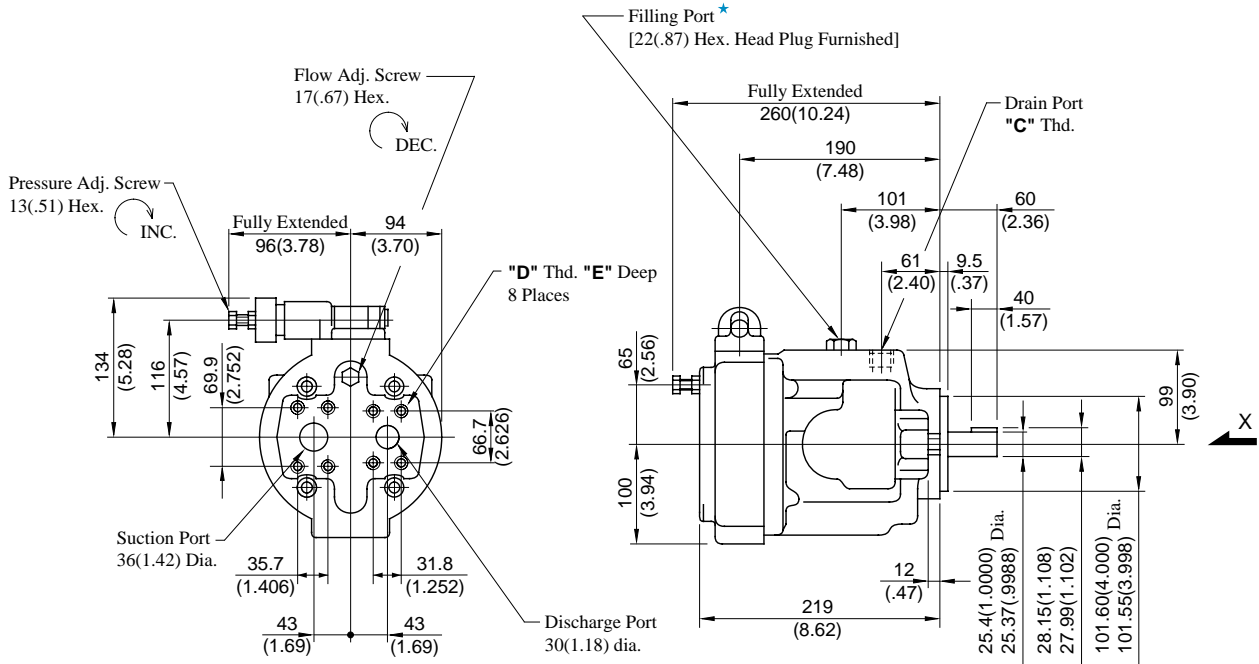

★ Install the pump so that the "Filling port" is at the top.

Model Numbers	"C" Thd.	"D" Thd.	E mm (IN.)
AH37-FR01KK-20	Rc 1/2	M12	19 (.75)
AH37-FR01KK-2080	1/2 BSP.F		
AH37-FR01KK-2090	1/2 NPT	1/2-13 UNC	21 (.83)

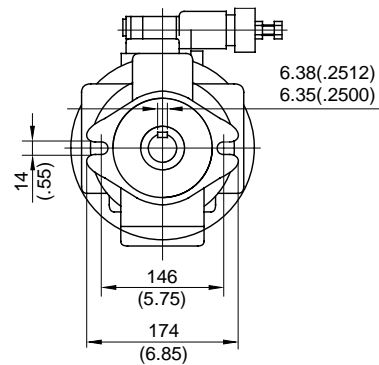

View Arrow X

DIMENSIONS IN  
MILLIMETRES (INCHES)

Foot Mtg.: AH37-LR01KK-20/2080/2090

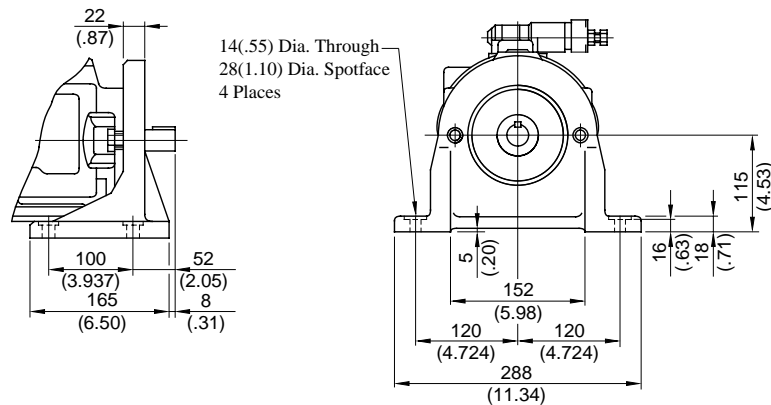

● For other dimensions, refer to "Flange Mtg.".

Flange Mtg.: AH56-FR01KK-11/1180/1190

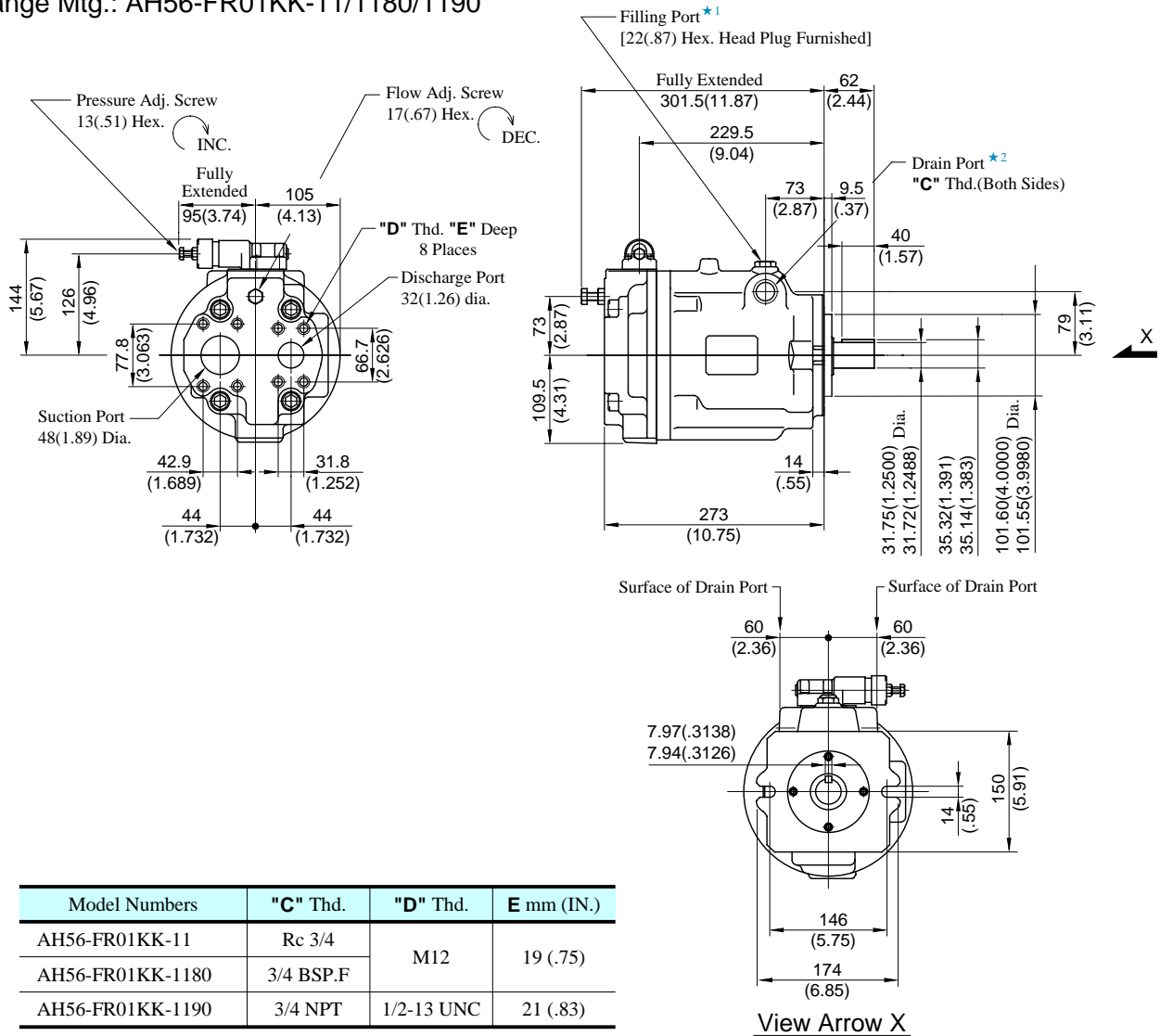

★1. Install the pump so that the "Filling Port" is at the top.

★2. Use either port of two drain ports at your option. Keep the remaining port plugged. Note that on the European design standard (1180 Design), only the left side, as viewed from the shaft end, of the drain port is machined.

**DIMENSIONS IN  
MILLIMETRES (INCHES)**

Foot Mtg. : AH56-LR01KK-11/1180/1190

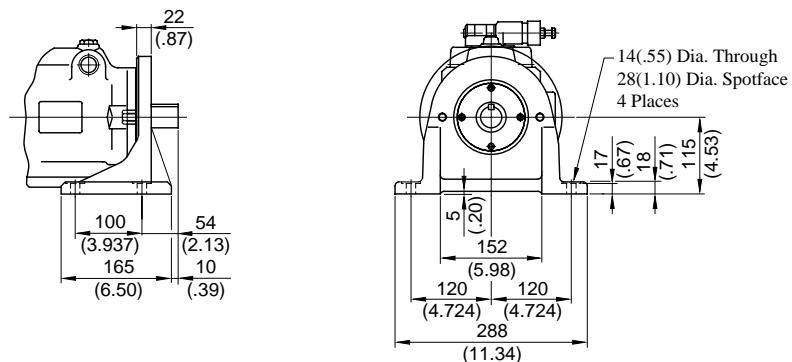

● For other dimensions, refer to "Flange Mfg."

### Spare Parts List

AH16-\*R01KK-10/1080/1090  
AH37-\*R01KK-20/2080/2090  
AH56-\*R01KK-11/1180/1190

### CAUTION

When making replacement of seals, or bearings, please do it carefully after reading through the relevant instructions in the Operator's Manual.

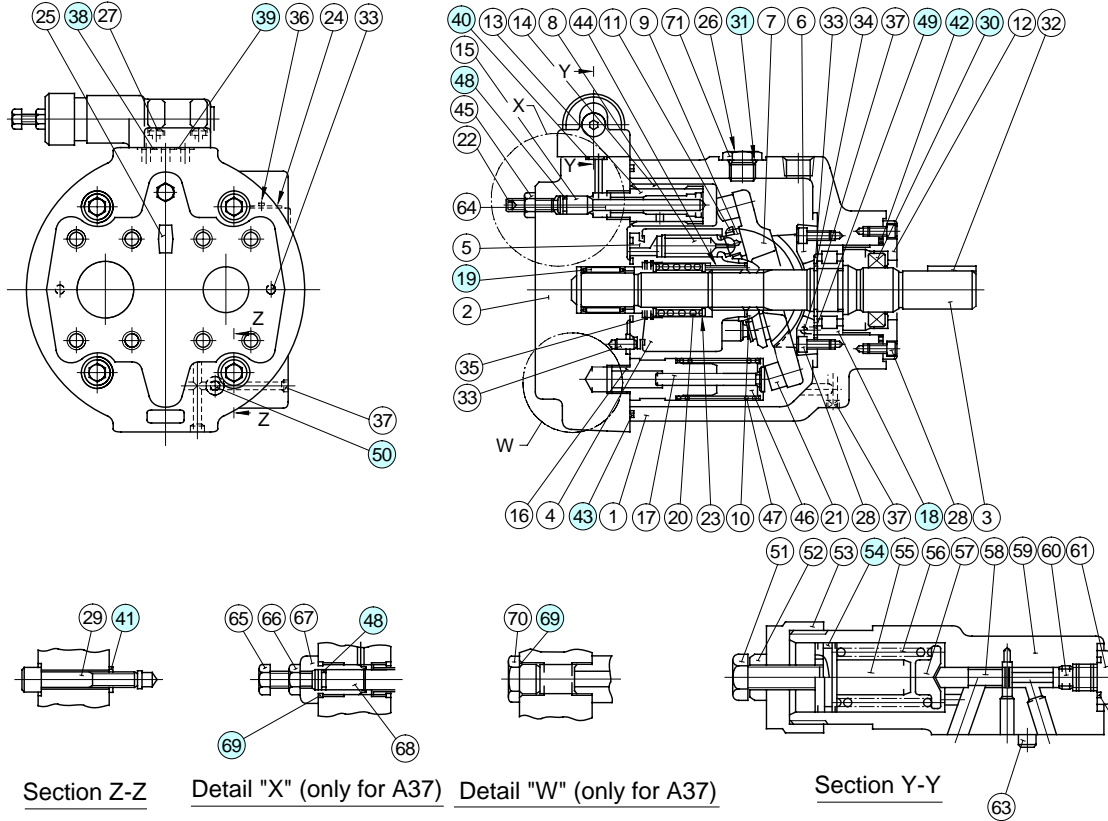

Section Z-Z

Detail "X" (only for A37)

Detail "W" (only for A37)

Section Y-Y

Item	Name of Parts	Parts Numbers			Qty.
		AH16	AH37	AH56	
18	Bearing	NUP 205E	NUP 206E	NUP 207E	1
19	Needle Bearing	HMK 2025V2	HMK 2530V2	HMK 3030V2	1
30*	Oil Seal	TCN 254511	TCN 355511	TCN 355511	1
31*	O-Ring		SO-NB-P14		1
38*	O-Ring		SO-NB-P9		1
39*	O-Ring	SO-NB-P11	SO-NB-P9	SO-NB-P9	1
40*	O-Ring		SO-NB-P9		1
41*	O-Ring	SO-NB-P12	SO-NB-P14	SO-NA-P20	4
42*	O-Ring	SO-NB-A139	SO-NB-G75	SO-NB-G75	1
43*	O-Ring	SO-NB-A162	SO-NB-A167	SO-NB-A170	1
48*	O-Ring		SO-NB-P8		1
49*	O-Ring	SO-NB-P6	SO-NB-P9	SO-NB-P9	1
50*	O-Ring		SO-NB-P9		1
54*	O-Ring		SO-NB-A018		1
62*	O-Ring		SO-NB-P10		1
69*	O-Ring	—	SO-NB-P18	—	2

\* When ordering seals, please specify the seal kit number from the table below.

#### ● List of Seal Kits

Pump Model Numbers	Seal Kit Numbers
AH16-*R01KK-10/1080/1090	KS-AH16-01-10
AH37-*R01KK-20/2080/2090	KS-AH37-01-20
AH56-*R01KK-11/1180/1190	KS-AH56-01-11